

# Differential Evolution Based Optimal Choice and Location of Facts Devices in Restructured Power System

K. Balamurugan, V. Dharmalingam, R. Muralisachithanandam, R. Sankaran

**Abstract**—This paper deals with the optimal choice and location of FACTS devices in deregulated power systems using Differential Evolution algorithm. The main objective of this paper is to achieve the power system economic generation allocation and dispatch in deregulated electricity market. Using the proposed method, the locations of the FACTS devices, their types and ratings are optimized simultaneously. Different kinds of FACTS devices such as TCSC and SVC are simulated in this study. Furthermore, their investment costs are also considered. Simulation results validate the capability of this new approach in minimizing the overall system cost function, which includes the investment costs of the FACTS devices and the bid offers of the market participants. The proposed algorithm is an effective and practical method for the choice and location of suitable FACTS devices in deregulated electricity market.

**Keywords**—FACTS Devices, Deregulated Electricity Market, Optimal Location, Differential Evolution, Mat Lab.

## I. INTRODUCTION

THE improvement of transmission technologies result in an efficient grid operated by the transmission companies. Devices such as FACTS enable a better control over the electrical features of the grid. This paper efficiently deals with the optimal placement of FACTS device in the transmission line to control its parameters like thermal capacity, reactance, and reactive power and so on. Years ago, large proportion of the electrical energy was traded through an unmanaged open market, where the reliability of the power system was not maintained. A managed spot market that would provide a mechanism for balancing load and generation must therefore supersede the open energy market. This resulted in the introduction of Deregulated Electricity market [1]. Global optimization is necessary in fields such as engineering, statistics and finance. But many practical problems have objective functions that are nondifferentiable, non-continuous, non-linear, noisy, flat, multi-dimensional or have many local minima, constraints or stochasticity such problems are

difficult if not impossible to solve analytically. DE can be used to find approximate solutions to such problems. A relatively new population based optimization technique; Differential Evolution has been attracting increasing attention for a wide variety of engineering applications including power engineering.

## II. DEREGULATED ELECTRICITY MARKET

### A. Motivation for Deregulation

Historically, the electricity industry was a monopoly industry with a vertical structure. In a vertically integrated environment, enterprises were responsible for the generation, transmission and distribution of electrical power in a given geographical area. Such companies could be state owned as well as private. But the last two decades, and especially during the 1990s, the electricity supply service has been undergoing a drastic reform all over the world. The old monopolist power markets are replaced with deregulated electricity markets open to the competition. Different causes which have driven the power market towards the deregulation are technical, economical and political factors. The technical factor which has given a stronger impulse towards the deregulation is the improved power generation technologies. Another mixed technical-ecological cause is the inclination of modern society for an increase in power produced by renewable sources. Beyond the technical improvements, a set of economical reasons may be considered as the main force behind the electricity market reform. The key economical idea, which led to the deregulation, was that a well operated competitive market can guarantee both cost minimization and average energy prices hold at a minimum level. Another economical reason was the inability of countries with high national debt to meet the necessary investments in state owned power sector. So, the only solution for these countries was the privatization of the electricity industry. The third category of electricity industry restructure causes consists of political factors. Among the political circles, the idea that the private companies apply more efficient practices than the public ones, in certain economic sectors, were getting more acceptances. Hence, the deregulation of power market was made possible in many countries [2]. A further reason, which led to the deregulation, is the pressure of some multilateral organizations such as World Bank.

Mr. K. Balamurugan is with the Department of Electrical and Electronics Engineering, SASTRA University, Thanjavur, Tamilnadu, India (e-mail: kbm@eee.sastra.edu, bala688@yahoo.com).

Dr. V. Dharmalingam is with the M.A.M school of Engineering, Tiruchirappalli, Tamilnadu, India (e-mail: dharmalingamv@yahoo.co.in).

Dr. R. Muralisachithanandam is with the Department of Electrical and Electronics Engineering, SASTRA University, Thanjavur, Tamilnadu, India (e-mail: zenmurali@gmail.com).

Dr. R. Sankaran is with the Department of Electrical and Electronics Engineering, SASTRA University, Thanjavur, Tamilnadu, India (e-mail: rs@eee.sastra.edu).

*B. Deregulated Electricity Market Structure*

In the restructured market, the power generation is a competitive sector, in which generation companies are able to take part in the market and sell their production. But the transmission and distribution remains monopoly. In recent years, with the deregulation of the electricity market, the traditional concepts and practices of power systems have changed. Two basic market forms, the bilateral contract market and the pool market are there to sell the electricity produced by several generation companies. Pool market is only considered here. The pool model is based on a centralized arrangement in order to achieve the optimal economic performance of the market. The main characteristic of electricity pool market is that the power is traded through the market and not directly between producers and consumers. The market is operated either by a separate Pool Operator or directly by the Independent System Operator. The task of market operator is to lead the pool market to a short-run economic optimum. In order to achieve this aim, the market operator collects the electric power bids from suppliers as well as from consumers. The bids are related to a certain time interval, usually half or one hour, and they are submitted to the ISO a day before the applicability of the time. Therefore, the modern pool markets are also known as a day ahead markets. When the bids are submitted, the market operator runs an OPF program taking into consideration the network constraints. The objective of this OPF program is to minimize the total costs also known as social welfare [3]. The OPF calculates spot prices for each location (bus) of the grid as well as the quantity of power that is to be supplied or bought by each of the market participant. Consumers and suppliers are then billed to the spot price of their bus for the corresponding amount of power. A schematic description of pool market operation is given by the below Fig. 1.

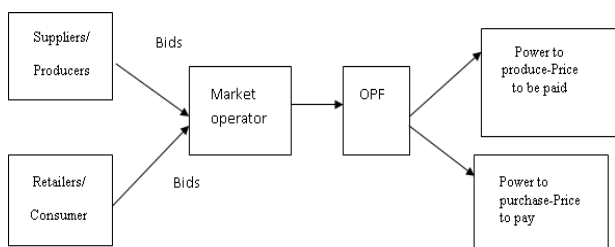

Fig. 1 Electricity pool market

Typical bid curves for the supplier and consumer are illustrated in Fig. 2. The supply and demand bid curves show the minimum prices to sell and buy a certain quantity of electrical power for the supplier and consumer respectively.

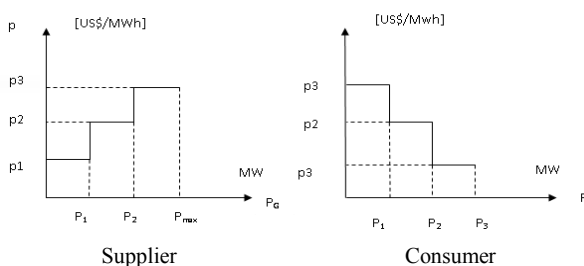

Fig. 2 Supplier and Consumer bid curves

The Pool Operator, the day before the corresponding time interval, feeds an optimal power flow program with the bids collected from the market participants. Generally, optimization problems aim to maximize or minimize a function while certain restrictions hold. In the deregulated pool market, the optimization problem has to serve a double task.

- To minimize the power generation costs.
- At the same to cover the load demand as much as possible.

The more power the consumers take the more profit they have through the use of power. So, if the consumers full demand is not covered those results in profit losses which can be seen as a kind of cost. Thus, the objective function of the OPF is called social welfare because it aims to minimize the global system costs and thereby to maximize the profit of all market participants [4], [5]. The objective function has the following form.

$$C_2(P_G, P_{UL}) = p_{min}^T P_G + p_{max}^T P_{UL} \tag{1}$$

where,

- $C_2$ : The total generation cost
- $P_G$ : Generation power
- $P_{UL}$ : Uncovered load
- $P_{min}$ : Minimal acceptable price (bid) of the suppliers
- $P_{max}$ : Maximal acceptable price (bid) of the consumers

Certain part of a particular load cannot be covered if the load bid for this part is lower than the suppliers bid or if system has congestions. In this research, the uncovered load is modeled as a fictitious generator. For the consumer bid curve of fictitious generator can be developed, as shown in Fig. 3.

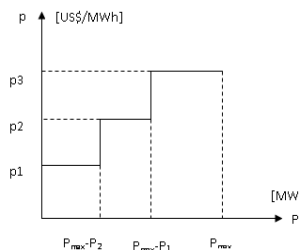

Fig. 3 Bid curve of fictitious consumer generator

A part of fictitious generator is dispatched if the corresponding bid price is lower than the suppliers' bid. It is

also possible this generator to be dispatched if system congestions prevent the full cover of the load. For a load located at bus  $i$  as follows

$$0 \leq P_{ULi} \leq P_{maxi} \quad (2)$$

$$P_{Li} = P_{Lmaxi} - P_{ULi} \quad (3)$$

where,

$P_{Li}$  : covered load portion at bus  $i$

$P_{Lmaxi}$ : maximum load demand at bus  $i$

Therefore, the above mentioned OPF objective function in the pool market can be now formulated as:

$$C_2(P_G) = p_{min}^T P_G \quad (4)$$

where the  $P_G$  represents the conventional generators and fictitious generators.

### III. FACTS DEVICES

#### A. Introduction

FACTS have the principal role to enhance controllability and power transfer capability in ac systems. Devices such as FACTS enable a better control over the electrical features of the grid. FACTS Controllers can enable a line to carry power closer to its thermal rating [6], [7]. The major possibilities of power flow control:

- Control of the line impedance  $X$  (e.g., with a thyristor controlled series capacitor) can provide a powerful means of current control.
- Injecting voltage in series with the line and with any phase angle with respect to the driving voltage can control the magnitude and the phase of the line current. This means that injecting a voltage phasor with variable phase angle can provide a powerful means of precisely controlling the active and reactive power flow. This requires injection of both active and reactive power in series.

#### B. Series Controllers

Series Controller could be variable impedance, such as capacitor, reactor, etc., or power electronics based variable source of main frequency, sub - synchronous and harmonic frequencies to serve the desired need. In principle, all series Controllers inject voltage in series with the line. Even variable impedance multiplied by the current flow through it, represents an injected series voltage in the line. As long as the voltage is in phase quadrature with the line current, the series Controller only supplies or consumes variable reactive power. In this paper we use series controller TCSC as shown in Fig. 4.



Fig. 4 Series controller

#### 1. Thyristor Controlled Series Capacitor (TCSC)

A capacitive reactance compensator consists of a series capacitor bank shunted by a thyristor - controlled reactor in order to provide a smoothly variable series capacitive reactance [8]. The TCSC is modeled to modify the reactance of the transmission line directly. By modifying the reactance of the transmission line, the TCSC acts as the capacitive or inductive compensation respectively. The reactance of the transmission line is adjusted by TCSC directly. The rating of TCSC is depends on the reactance of the transmission line where the TCSC is located.

$$X_{ij} = X_{line} + X_{TCSC} \quad (5)$$

$$X_{TCSC} = r_{TCSC} * X_{TCSC} \quad (6)$$

where  $X_{line}$  is the reactance of the transmission line and  $r_{tcsc}$  is the coefficient which represents the degree of compensation by TCSC. To avoid overcompensation, the working range of the TCSC is chosen between  $-0.7X_{line}$  and  $0.2 X_{line}$ . The cost function for TCSC is

$$C_{TCSC} = 0.0015s^2 - 0.2691s + 188.22 \left( US \frac{\$}{kVar} \right) \quad (7)$$

where  $C_{TCSC}$  is in US\$/kVar and 's' is the operating range of the FACTS device in MVar.

#### C. Shunt Controllers

As in the case of series Controllers, the shunt Controllers may be variable impedance, variable source, or a combination of these. In principle, all shunt Controllers inject current into the system at the point of connection. Even variable shunt impedance connected to the line voltage causes a variable current flow and hence represents injection of current into the line. As long as the injected current is in phase quadrature with the line voltage, the shunt Controller only supplies or consumes variable reactive power. Any other phase relationship will involve handling of real power as well. In this paper shunt controller SVC as shown in Fig. 5 are used.

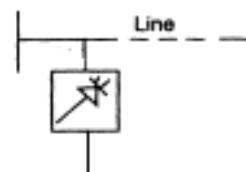

Fig. 5 Shunt controller

#### 1. Static Var Compensator (SVC)

A shunt - connected static Var generator or absorber whose output is adjusted to exchange capacitive or inductive current so as to maintain or control specific parameters of the electrical power system [9]. The SVC can be operated as both inductive and capacitive compensation. It is modeled as an ideal reactive power injection at sending end bus. SVC is based on thyristors without the gate turn-off capability. It

includes separate equipment for leading and lagging Vars; the thyristor-controlled or thyristor-switched reactor for absorbing reactive power and thyristor-switched capacitor for supplying the reactive power.

$$\Delta Q_{is} = Q_{SVC} \quad (8)$$

The cost function for SVC device is

$$C_{SVC} = 0.0003s^2 - 0.3051s + 127.38 \left( US \frac{\$}{kVar} \right) \quad (9)$$

where  $C_{SVC}$  is in US\$/kVar and  $s$  is the operating range of the FACTS device in MVar.

#### IV. DIFFERENTIAL EVOLUTION

##### A. Introduction

DE is based on the concept of a population of individuals that evolve and improve their fitness through probabilistic operators like recombination and mutation. These individuals are evaluated and those that perform better are selected to compose the population in the next generation. After several generations these individuals improve their fitness as they explore the solution space for optimal value. In 1995, price and Storn proposed a new floating point encoded evolutionary algorithm for global optimization and named it Differential Evolution (DE) algorithm owing to a special kind of differential operator, which they invoked to create new offspring from parent chromosomes instead of classical crossover or mutation. Differential evolution algorithm is a population-based algorithm such as genetic algorithms using similar operators; crossover, mutation and selection as shown in Fig. 6. The main difference between the genetic algorithm and DE is the mutation scheme that makes DE self-adaptive and the selection process. In DE, all the solutions have the same chance of being selected as parents. DE employs a greedy selection process: the better one of new solution and its parent wins the competition providing significant advantage of converging performance over genetic algorithms. Easy methods of implementation and negligible parameters tuning made the DE quite popular very soon. It has been applied to several engineering problems in different areas [10]-[13].

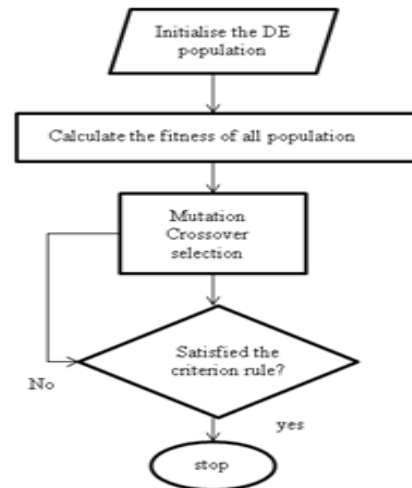

Fig. 6 Flow Chart of DE

##### B. Main Steps of the DE Algorithm

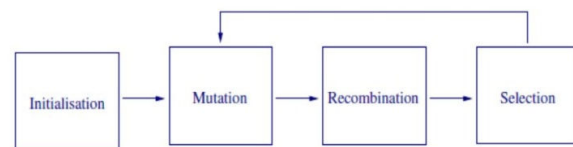

Fig. 7 General DE Procedure

##### 1. Initialization

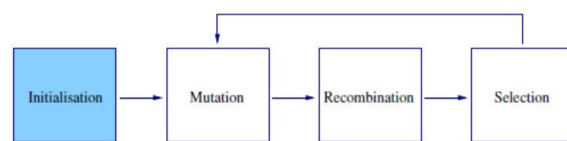

Fig. 8 DE Procedure with Initialization

The first step in the DE optimization process is to create an initial population of candidate solutions by assigning random values to each decision parameter of each individual of the population. Such values must lie inside the feasible bounds of the decision variable.

$$X_j^L \leq X_{j,i,1} \leq X_j^U \quad (10)$$

##### 2. Mutation

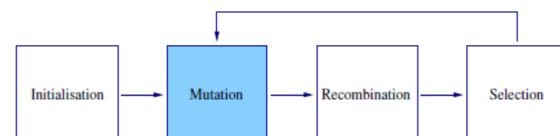

Fig. 9 DE Procedure with Mutation

After the initialization of population, this undergoes the various stages of operation such as mutation, cross over and selection. The mutation operator creates new parameters into

the population. For a given parameter vector  $X_{i,G}$  randomly select three vectors  $X_{r1,G}$ ,  $X_{r2,G}$  and  $X_{r3,G}$  such that the indices  $i$ ,  $r1$ ,  $r2$  and  $r3$  are distinct. All of these vectors must be different from each other, requiring the population to be of at least four individuals to satisfy this condition. To control the perturbation and improve convergence, the difference vector is scaled by a user defined constant in the range  $[0, 1.2]$ . This constant is commonly known as the scaling constant ( $F$ ). Add the weighted difference of two of the vectors to the third.

$$V_{i,G+1} = X_{r1,G} + F(X_{r2,G} - X_{r3,G}) \quad (11)$$

The mutation factor  $F$  is a constant from  $[0, 1]$ .  $V_{i,G+1}$  is called the donor vector.

3. Crossover

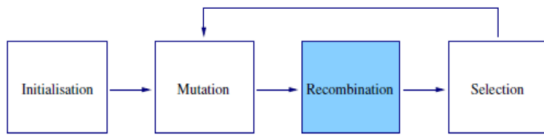

Fig. 10 DE Procedure with Crossover

The Trial vector is created by the crossover operators that are used in the selection process. A trial vector is a combination of a mutant vector and a parent (target) vector based on uniform, binomial and exponential distribution that are generated in the range  $[0, 1]$  and compared against a user defined constant referred to as the crossover constant. If the value of the random number is less or equal than the value of the crossover constant, the parameter will come from the mutant vector, otherwise the parameter comes from the parent vector. The crossover operation maintains diversity in the population, preventing local minima convergence. The crossover constant ( $CR$ ) must be in the range of  $[0, 1]$ .

- The trial vector  $U_{i,G+1}$  is developed from the elements of the target vector,  $X_{i,G}$ , and the elements of the donor vector,  $V_{i,G+1}$
- Elements of the donor vector enter the trial vector with probability  $CR$ .

$$U_{j,i,G+1} = \begin{cases} V_{j,i,G+1} & \text{if } rand_{j,i} \leq CR \text{ or } j = I_{rand} \\ X_{j,i,G+1} & \text{if } rand_{j,i} > CR \text{ and } j \neq I_{rand} \end{cases} \quad (12)$$

$i = 1, 2, \dots, N; j = 1, 2, \dots, D$

- $rand_{j,i} \sim U[0, 1]$ ,  $I_{rand}$  is a random integer from  $[1, 2, \dots, D]$
- $I_{rand}$  ensures that  $V_{i,G+1} \neq X_{i,G}$
- $CR \in [0, 1]$  is the crossover probability that constitutes a control variable for the DE scheme and affects the convergence velocity, robustness of the search process.

4. Selection

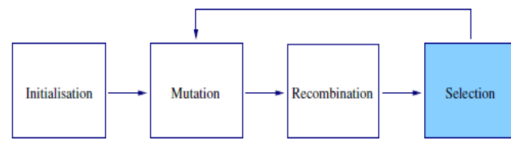

Fig. 11 DE Procedure with Selection

The vector population in the next generation is chosen by the selection operator. It compares the fitness of the trial vector and fitness of the target vector, one of the best vectors is chosen. The target vector  $X_{i,G}$  is compared with the trial vector  $V_{i,G+1}$  and the one with the lowest function value is admitted to the next generation.

$$X_{i,G+1} = \begin{cases} U_{i,G+1} & \text{if } f(U_{i,G+1}) \leq f(X_{i,G}) \\ X_{i,G} & \text{Otherwise} \end{cases} \quad (13)$$

Mutation, recombination and selection continue until some stopping criterion is reached.

V. CASE STUDY

A. Procedure

1. The standard 10-bus test system is considered to investigate the effectiveness of the proposed approach as shown in Fig. 12. The bid offers market participants of the system is shown in Table I. The load curve of the day is taken as shown in Fig. 13.
2. Run the Mat Lab coding for Differential Evolution technique without FACTS devices for all the load demands and find out the bid offers market participants cost.

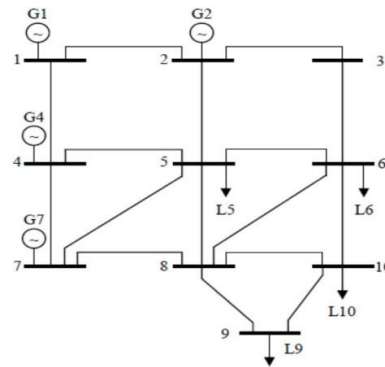

Fig. 12 Single Line diagram of 10 bus test system

TABLE I  
BID OFFERS OF THE MARKET PARTICIPANTS

Bus	Art	Bid offers for time interval			
		$P_{max}$ [MW], $P_{max}$ [ct/kWh]			
		23-8	8-12	12-17	17-23
1	Supplier	150,3	150,5,4	150,5,5	150,4,5
2	Supplier	150,6	150,5,4	150,5,5	150,4,5
4	Supplier	150,6	150,5,4	150,5,5	150,4,5
7	Supplier	250,15	250,19	250,18,5	250,17,5
5	Consumer	100,20	100,36	100,34	100,30
6	Consumer	100,20	100,36	100,34	100,30
9	Consumer	100,20	100,36	100,34	100,30
10	Consumer	100,20	100,36	100,34	100,30

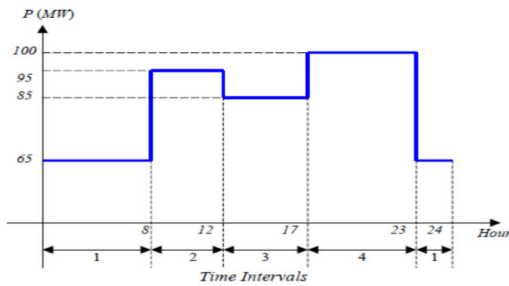

Fig. 13 Typical load curve of the day

- Run the Mat Lab coding for Differential Evolution technique without FACTS devices for all the load demands and find out the bid offers market participants cost.
- Run the Mat Lab coding for Differential Evolution technique with FACTS devices for all the load demands and find out the total cost which includes the bid offers market participants cost and investment cost of the FACTS devices.
- The total system cost as modeled as sum of investment cost of the FACTS devices and bid offers market participant cost (Generation cost) is given by

$$\text{Min } C_{Total} = C_1(f) + C_2(P_G) \quad (14)$$

where  $C_2(P_G)$  is the bid offers market participants cost,  $C_1(f)$  is the investment cost of the FACTS devices.

$$C_2(P_G) = p_{min}^T P_G \quad (15)$$

$$C_{TCSC} = 0.0015s^2 - 0.2691s + 188.22 \left( US \frac{\$}{kvar} \right) \quad (16)$$

$$C_{SVC} = 0.0003s^2 - 0.3051s + 127.38 \left( US \frac{\$}{kvar} \right) \quad (17)$$

- The line data and bus data for 10 bus test system are given in Tables II and III. Run the Mat Lab coding for Newton Raphson load flow analysis and check the capacity of the each transmission line.

TABLE II  
BUS DATA VALUES OF 10-BUS TEST SYSTEM

Bus	Type	$V_{sp}$	Theta	$P_{Gi}$	$Q_{Gi}$	$P_{Li}$	$Q_{Li}$	$Q_{min}$	$Q_{max}$
1	2	1.04	0	150	0	0	0	-50	50
2	2	1.04	0	150	0	0	0	-50	50
3	3	1.0	0	0	0	0	0	0	0
4	2	1.04	0	150	0	0	0	-50	50
5	3	1.0	0	0	0	100	0	0	0
6	3	1.0	0	0	0	100	0	0	0
7	2	1.04	0	250	0	0	0	-50	50
8	3	1.0	0	0	0	0	0	0	0
9	3	1.0	0	0	0	100	0	0	0
10	3	1.0	0	0	0	100	0	0	0

TABLE III  
LINE DATA VALUES OF 10-BUS TEST SYSTEM

From Bus	To Bus	R [p.u.]	X[p.u.]	B[p.u.]	Capacity [MVA]
1	2	0.0034	0.00360	1.2696	100
1	4	0.0034	0.00360	1.2696	110
2	3	0.0034	0.00360	1.2696	120
2	5	0.0034	0.00360	1.2696	120
3	6	0.0034	0.00360	1.2696	150
4	5	0.0034	0.00360	1.2696	70
4	7	0.0028	0.00288	1.0156	100
5	6	0.0028	0.00288	1.0156	85
5	7	0.0034	0.00360	1.2696	70
5	8	0.0017	0.00180	0.6348	65
6	10	0.0024	0.00252	0.8888	85
6	8	0.0034	0.00360	1.2696	80
7	8	0.0017	0.00180	0.6348	94
8	9	0.0017	0.00180	0.6348	155
8	10	0.0028	0.00288	1.0156	115
9	10	0.0024	0.00252	0.8888	50

- The transmission line which violates its capacity limits is the optimal place for placing the FACTS devices.
- Run the Mat Lab coding for Newton Raphson load flow analysis by changing the reactance value of the transmission line for which the capacity is violated in case of using TCSC or by changing the value of reactive power of the transmission line in case of SVC. The capacity should come within the limit.

## VI. SIMULATION RESULT AND INTERPRETATION

### A. Without FACTS device

TABLE IV  
OUTPUT WITHOUT FACTS DEVICES

	PD=65 (MW)	PD=95 (MW)	PD=85 (MW)	PD=100 (MW)
Supplier 1(MW)	21.4997	23.3583	20.4018	16.5363
Supplier 2(MW)	18.1312	37.5381	20.7509	24.6137
Supplier 3(MW)	11.9933	11.7197	11.9877	37.4807
Supplier 4(MW)	14.0522	24.1327	32.0487	21.3886
Total generation cost(US\$)	75.5746	135.9436	130.8246	139.7070

B. With TCSC device

TABLE V  
OUTPUT WITH TCSC DEVICE

	PD=65 (MW)	PD=95 (MW)	PD=85 (MW)	PD=100 (MW)
Supplier 1(MW)	19.6556	10.2464	12.0681	43.3812
Supplier 2(MW)	13.8422	26.5724	50.4575	12.1391
Supplier 3(MW)	19.4319	32.5245	11.6668	35.5342
Supplier 4(MW)	12.4696	25.7809	11.1846	9.0848
Total cost(US\$)	73.0196	130.1656	118.4460	134.3906
X <sub>TCSC</sub>	0.0000956	-0.0789	0.0000708	0.0001062

C. With SVC device

TABLE VI  
OUTPUT WITH SVC DEVICE

	PD=65 (MW)	PD=95 (MW)	PD=85 (MW)	PD=100 (MW)
Supplier 1(MW)	18.1348	15.1363	21.4822	14.8487
Supplier 2(MW)	14.5570	49.8962	21.7849	20.1042
Supplier 3(MW)	20.177	20.4514	22.7342	47.1908
Supplier 4(MW)	12.7041	9.6270	19.8344	18.1514
Total cost(US\$)	73.3056	121.917	116.1812	133.4821
Q <sub>SVC</sub> (Mvar)	85.5720	93.7688	90.2507	71.5008

TABLE VII  
LOAD FLOW SOLUTION WITHOUT FACTS DEVICE

From Bus	To Bus	P MW	Q MVar	From Bus	To Bus	P MW	Q MW	Line Losses MW	Line losses MVar
1	2	-34.431	-833.48	2	1	55.891	856.210	21.460	22.723
1	4	-56.761	-813.35	4	1	77.262	835.065	20.501	21.707
2	3	47.251	-138.26	3	2	-46.62	138.924	0.622	0.659
2	5	46.858	-23.727	5	2	-46.77	23.812	0.080	0.085
3	6	46.628	10.024	6	3	-46.56	-9.954	0.066	0.070
4	5	69.385	-44.883	5	4	-69.18	45.094	0.199	0.211
4	7	3.353	373.351	7	4	-0.007	-369.90	3.346	3.442
5	6	55.552	-129.42	6	5	-55.07	129.914	0.477	0.490
5	7	-69.805	347.769	7	5	73.477	-343.88	3.672	3.888
5	8	30.217	30.728	8	5	-30.19	-30.700	0.027	0.029
6	10	32.628	19.784	10	6	-32.59	-19.753	0.030	0.031
6	8	-30.991	120.051	8	6	31.438	-119.57	0.447	0.473
⇒ 7	8	176.530	-656.92	8	7	-169.6	66.203	6.871	7.275 ←
8	9	103.504	-139.31	9	8	-103.0	139.780	0.440	0.466
8	10	64.907	-131.03	10	8	-64.39	131.560	0.515	0.530
9	10	3.064	-51.083	10	9	-3.010	51.139	0.054	0.057
						Line Losses	Losses	58.808	62.136

TABLE VIII  
LOAD FLOW SOLUTION WITH TCSC DEVICE

From Bus	To Bus	P MW	Q MVar	From Bus	To Bus	P MW	Q MVar	Line Losses MW	Line losses MVar
1	2	-34.242	-825.342	2	1	55.692	848.054	21.450	22.12
1	4	-57.042	-804.797	4	1	77.505	826.464	20.463	21.666
2	3	47.408	-133.679	3	2	-46.811	134.312	0.597	0.633
2	5	46.900	-19.894	5	2	-46.823	19.975	0.077	0.082
3	6	46.811	11.863	6	3	-46.742	-11.790	0.069	0.073
4	5	69.898	-41.495	5	4	-69.702	41.703	0.196	0.208
4	7	2.597	370.628	7	4	0.763	-367.17	3.360	3.456
5	6	55.966	-126.223	6	5	-55.499	126.703	0.467	0.480
5	7	-70.916	342.123	7	5	74.547	-338.27	3.631	3.844
5	8	31.474	34.456	8	5	-31.442	-34.422	0.032	0.034
6	10	32.901	20.692	10	6	-32.869	-20.659	0.032	0.033
6	8	-30.660	119.304	8	6	31.110	-118.82	0.450	0.476
7	8	174.691	-651.600	8	7	-167.80	658.728	6.886	7.129
⇒ 8	9	103.385	-137.178	9	8	-102.94	37.644	0.440	0.466 ←
8	10	64.753	-129.317	10	8	-64.240	12.845	0.513	0.528
9	10	2.945	-50.625	10	9	-2.891	50.682	0.054	0.057
						Line Losses	Losses	58.716	61.876

TABLE IX  
LOAD FLOW SOLUTION WITH SVC DEVICE

From Bus	To Bus	P MW	Q MVar	From Bus	To Bus	P MW	Q MVar	Line Losses MW	Line losses MVar
1	2	-34.242	-825.342	2	1	55.692	848.054	21.450	22.12
1	4	-57.042	-804.797	4	1	77.505	826.464	20.463	21.666
2	3	47.408	-133.679	3	2	-46.811	134.312	0.597	0.633
2	5	46.900	-19.894	5	2	-46.823	19.975	0.077	0.082
3	6	46.811	11.863	6	3	-46.742	-11.790	0.069	0.073
4	5	69.898	-41.495	5	4	-69.702	41.703	0.196	0.208
4	7	2.597	370.628	7	4	0.763	-367.17	3.360	3.456
5	6	55.966	-126.223	6	5	-55.499	126.703	0.467	0.480
5	7	-70.916	342.123	7	5	74.547	-338.27	3.631	3.844
5	8	31.474	34.456	8	5	-31.442	-34.422	0.032	0.034
6	10	32.901	20.692	10	6	-32.869	-20.659	0.032	0.033
6	8	-30.660	119.304	8	6	31.110	-118.82	0.450	0.476
7	8	174.691	-651.600	8	7	-167.80	658.728	6.886	7.129
⇒ 8	9	103.385	-137.178	9	8	-102.94	37.644	0.440	0.466 ←
8	10	64.753	-129.317	10	8	-64.240	12.845	0.513	0.528
9	10	2.945	-50.625	10	9	-2.891	50.682	0.054	0.057
						Line Losses	58.716	61.876	

The total generation cost for all the load demands and for all the suppliers, without FACTS device, with TCSC and with SVC are shown in Tables IV-VI.

➤ Without FACTS devices

$$C_2 (P_G) = 75.5746*(9/24) + 135.9436*(4/24) + 30.8246*(5/24) + 139.7070*(6/24) = 113.1796$$

➤ With FACTS devices(TCSC)

$$C_2 (P_G) = 73.0196*(9/24) + 130.1656*(4/24) + 18.4460*(5/24) + 134.3906*(6/24) = 107.3505$$

➤ With FACTS vices(SVC)

$$C_2 (P_G) = 73.3056*(9/24) + 121.9170*(4/24) + 6.1812*(5/24) + 133.4821*(6/24) = 105.384$$

From the Table VII shows that, the transmission line 7 – 8 have violated the thermal limits. After installing the single TCSC device at the line, the thermal limits of the transmission line 7 – 8 has been reduced as shown in Table VIII. Same way after installing the single SVC device, the thermal limits of the transmission line 7 – 8 has been reduced as shown in Table IX. If more number of the FACTS devices installed in that line, the thermal limits will be satisfied.

#### D. Interpretation

The generation cost in both the cases i.e. with FACTS devices and without FACTS devices is compared and it is found that the generation cost with FACTS devices is less than the generation cost without FACTS devices. Newton Raphson Load Flow program has been run without FACTS devices and found out that the 7-8 transmission line has violated the thermal limits. The thermal limit of the transmission lines should be within the limits. In order to achieve this, The FACTS devices is to be placed in this particular transmission

line and the reactance value has to be changed in the case if TCSC is used and reactive power value has to be changed if SVC is used.

#### VII. CONCLUSION

In this report DE algorithm has been used to find the best locations of FACTS devices in order to minimize the overall cost function. Two different cases are considered, first is based upon the system excluding FACTS devices and second case deals with the system including FACTS devices. In the first case, when the Newton Raphson Load Flow program was executed, it was found that 7-8 transmission line is violating the capacity limits. So the FACTS devices optimal placement is to be done in the corresponding transmission line. After locating the FACTS devices in the above mentioned location, it was found that the capacity of the transmission line comes within the thermal limit. The proposed approach is tested in 10-bus test system. Several iterations are carried out on a test system and the results are shown. From the results it is clear that DE approach gives the best global optimum solution with less computation time than the other techniques. The results clearly show the ability of DE algorithm to provide a fast global optimum solution.

#### REFERENCES

- [1] L.J. Cai, I. Erlich and G. Stamsis, "Optimal choice and allocation of FACTS devices in deregulated electricity markets using genetic algorithms", *IEEE Power Engineering Society Power System Conference and Exposition*, vol. 1, pp 201-207, October 2004.
- [2] S.C. Srivastava and R.K. Verma, "Impact of FACTS devices on transmission pricing in a deregulated electricity market", *International Conference on Electric Utility Deregulation and Restructuring and Power Technologies*, pp 642- 648, April 2000.
- [3] E. Handschin and C. Lehmkoetter, "Optimal Power Flow for Deregulated System with FACTS Devices", *Proc. 13th PSCC, Trondheim, Norway*, pp.1270-1276, June1999.
- [4] J.D. Finney, H.A. Othman, W.L. Rutz, "Evaluating transmission congestion constraints in system planning", *IEEE Trans. on PowerSystems*, vol. 12, pp. 1143-1150, August 1997.



- [5] G.C. Stamtzis, "Power Transmission Cost Calculation in Deregulated Electricity Market", *Logos Verlag Berlin, ISBN 3-8325-0452-4*, Berlin 2004.
- [6] S. Gerbex, R. Cherkaoui, and A. J. Germond, "Optimal location of multitype FACTS devices in a power system by means of genetic algorithms", *IEEE Trans. Power Systems*, vol. 16, pp. 537-544, August 2001.
- [7] L.J. Cai, "Robust Coordinated Control of FACTS Devices in Large Power Systems", *Logos Verlag Berlin, ISBN 3-8325-0570-9*, Berlin 2004.
- [8] Lijun Cai and Istvan Erlich, "Optimal Choice and Allocation of FACTS Devices using Genetic Algorithms", *ISAP, Intelligent System Application to Power System*, Lemnos, Greece, August 31 – September 3, 2003.
- [9] T. S. Chung, and Y. Z. Li, "A hybrid GA approach for OPF with consideration of FACTS devices", *IEEE Power Engineering Review*, pp.47-57, February. 2001. M. Young, *the Technical Writers Handbook*. Mill Valley, CA: University Science, 1989.
- [10] R. Storn, "Differential Evolution, A Simple and Efficient Heuristic Strategy for Global Optimization over Continuous Spaces", *Journal of Global Optimization*, Vol. 11, Dordrecht, pp. 341-359, 1997.
- [11] Price, K.V. (1999), "An Introduction to Differential Evolution" in *Corne, D., Dorigo, M. and Glover, F. (Eds), New Ideas in Optimization*, McGraw- Hill, London.
- [12] Storn, R. and Price, K., "Differential Evolution - A Simple and Efficient Heuristic for Global Optimization over Continuous Spaces", *Journal of Global Optimization*, vol. 11, pp. 341–359, 1997.
- [13] Mrs. S. Latha, Mrs. Raja Mary Slochanal & Mr. K. Balamurugan, Optimum size and Location of UPFC Using the Method of Evolutionary Programming, *IE-Journal (EL)*, Vol-83, Page No. 242 to 245, Dec-2002.