

Mechanical Properties of Pea Pods (*Pisium sativum* Var. Shamshiri)

M. Azadbakht, N. Tajari, R. Alimoradzade

Abstract—Knowing pea pods mechanical resistance against dynamic forces are important for design of combine harvester. In pea combine harvesters, threshing is accomplished by two mechanical actions of impact and friction forces. In this research, the effects of initial moisture content and needed impact and friction energy on threshing of pea pods were studied. An impact device was built based on pendulum mechanism. The experiments were done at three initial moisture content levels of 12.1, 23.5 and 39.5 (%w.b.) for both impact and friction methods. Three energy levels of 0.088, 0.126 and 0.202 J were used for impact method and for friction method three energy levels of 0.784, 0.930 and 1.351 J. The threshing percentage was measured in each method. By using a frictional device, kinetic friction coefficients at above moisture contents were measured 0.257, 0.303 and 0.336, respectively. The results of variance analysis of the two methods showed that moisture content and energy have significant effects on the threshing percentage.

Keywords—Pea pod, Energy, Friction, Impact, Initial moisture content, Threshing.

I. INTRODUCTION

As a protein supplier, beans have high food value and it constitutes main part of food people in developing countries in dry regions. One of the gram family plants, pea or green pea is a proper plant for the regions with cold climates and relative humidity. It is desirable for winter planting in tropical regions. In the regions which cereal planting is common in form of rainfed and annual average precipitation is 300mm, it is a proper plant for cultivating alternatively with cereals. Pea are consumed both dried from and fresh (green) form. Pea is material for canning factories and producing frozen pea. It has about 9.22% protein, 3.2% fat and 65.9% carbohydrates [5]. Pea (*Pisium sativum*) is a gramineous annual plant from *Leguminosae* family, psychrophilic, with long ascending branches and it is cultivated for using its green grains [5].

As pod moisture, thrasher's speed, product figure, pod size on percentage of broken grains and percentage of threshing of pods. So that is important for proper and principled design of pea combine, determination of proper moisture of grain in stripper combines harvester, pods picking operation is done by

several finger rows which are mounted on moving cylinder. The circular motion of cylinder in stripper and combine's moving forward leads to penetrate fingers into bushes, pick pods and throw them upward. Selecting incorrectness of stripper cylinder's circular motion and clashing fingers with pods (during throwing upward) are other factors for breaking and damaging grains. So knowing grain's mechanical resistance against dynamic forces are important for designing proper speed of stripper combine, while it is important for designing thrasher too.

There are numerous methods to measure the mechanical properties proposed in the specialized literature: Reviewing conducted researches on other grain crops such as soybean, sorghum and bean indicates that in harvesting these crops by machines, some factors are very important such during planting and studying the impact of these factors on percentage of broken grains and percentage of threshing pods [11]. Reference [9] found that with increasing moisture in bean grain, broken grains will decrease significantly. References [14], [15], [7], [10] also reported significant impact of thresher's speed and grain moisture on percentage of broken gains in soybean. The relation between moisture and energy for threshing of soy beans, canola and beans found by impact and friction methods [3], [4], [8]. References [12], [13] used two belt system and ballistic pendulum, respectively, for determination of the relation between moisture and energy for threshing of soy beans. Reference [16] reported higher capacity and lower damage to kernels with a twin-rotor system than with a conventional transverse threshing cylinder. The power requirement of the twin-rotor system is expected to be similar to that of the conventional cylinder and concave due to the higher rotational speed, greater length, and smaller diameter of the twin-rotor system. Reference [6] made a two belt system which done the threshing operation between two parallel belt with beneath surfaces. Result of their experiment was less losses and more clean seeds. Similar experiments with two belt system and vertical belts were done on threshing grains and vegetables. The amounts of threshing increased by increasing of width and velocity of belts and reduce of distance between them.

In grain combine harvesters, threshing mechanism of pea is mainly accomplished by mechanical action of impact force. Threshing performance is related to moisture content. So the main objective of this study was to find the relation of primitive moisture content and energy consumption on pea pod threshing by two mechanical actions of impact and friction forces.

Mohsen Azadbakht is with the Department of Agricultural Machinery Engineering, Gorgan University of Agricultural Sciences and Natural Resources, Gorgan, Iran (Corresponding author; Tel: +981714426942; email: azadbakht@gau.ac.ir).

Neda Tajari is with the Department of Agricultural Machinery Engineering, Gorgan University of Agricultural Sciences and Natural Resources, Gorgan, Iran.

Roya Alimoradzade is with the Department of Environmental Health Engineering, Zanjan University of Medical Sciences, Zanjan, Iran.

II. MATERIALS AND METHOD

A. Sample Preparation

Pea harvested from the experimental farm in Gorgan, Iran, was used in the study. Samples were stored in a refrigerator at 3°C prior to the drying experiments. Moisture content was determined using the standard oven drying procedure ASAE Standard S.352 [2]. Three 50g samples were dried in an oven at 103°C for 17 h to determine initial moisture content. Pea sample moisture contents were selected at the range of 12.1, 23.5 and 39.5% (w.b.).

B. Impact Test

For impact test, pendulum system was built (Fig. 1). The distance between two beams (7) was equal to the length of pivot axle (5) was 21.5cm. The length of pendulum arm (4) (height of pendulum axle to center of weight (2) was 27.3cm and its weigh was 70.2g. There is a gap in sample support (3) that held the pods vertically. Calibrated plate (9) was calibrated from 0 to 180°. By this plate and pointer angle of impact and return was measured.

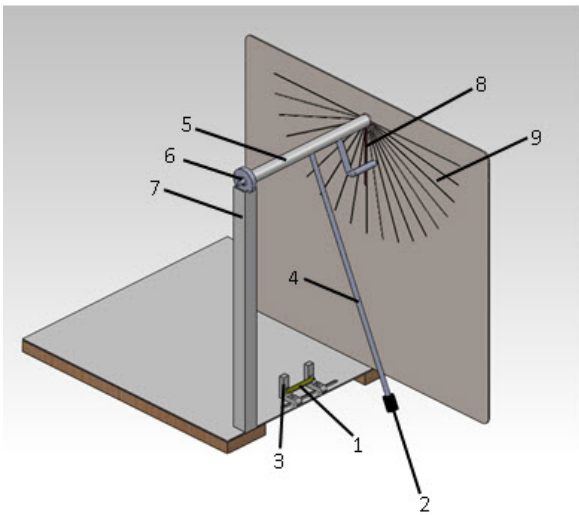

Fig. 1 Pendulum impact system 1. sampel 2. weight 3. sample support 4. pendulum arm 5. pivot axle 6. bearing 7. beam 8. pointer 9. calibrated plate

To create different levels of energy, three weights (5.9, 11.42, and 17.6g) were used. These weights were found in try and error method which pods break in the minimum amount, and the seeds not damaged in the maximum amount. According to the Fig. 2 and principal of work and energy, the amount of work between place 1 and 2 is equal to sum of change of kinesthetic and potential energy [1].

$$\Delta_{1-2} = \Delta(T + V_g) \quad (1)$$

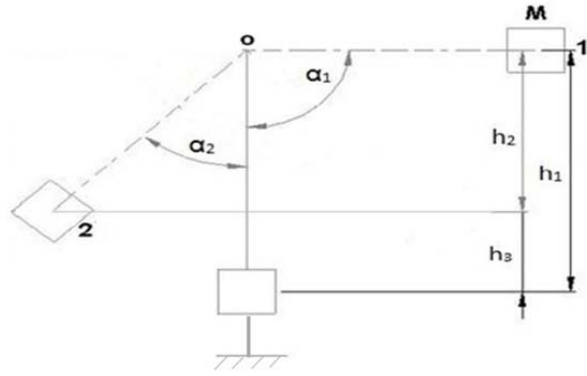

Fig. 2 Impact and after impact angle

After impact, the situation of pendulum in return angle will be in place (2). Kinesthetic energy in place 1 and 2 is zero, so the amount of work after impact is:

$$\Delta_{1-2} = \Delta v_g = Mg[h_1 - h_3] = Mg[h_1 - (h_1 - h_2)] = Mgh_2 \quad (2)$$

where, length of pendulum arm = $h_1 = R = 27.3$ cm, $\alpha_1 = 90^\circ$, $h_2 = R \cos \alpha_2$, $h_3 = h_1 - h_2$. According to (2), three energy levels of 0.202, 0.126 and 0.088J were measured. To do the experiment, first 50g of each sample in different moisture levels were weighted and then pods held horizontally in the support place, pods which their pea seeds were separated by impact, weighed and divided by initial weight to calculate the percent of threshing due to impact. This process was repeated three times for all levels and data were analyzed by using of completely randomized design (CRD) and SAS software.

C. Friction Test

Friction Device (Fig. 3) was used in this experiment. This device's working principles are that mass 1 that is connected to the plate 6 by a string with a negligible friction moved down, by this action plate number 6 and the loaded weight start to move. Surfaces used in this test were two pieces of wood with equal dimension 10×17 cm and 12×70. Wooden surfaces were jagged by saw. On the upper wood a 352 g mass was loaded. This amount was measured during several examinations so that in the static status pods don't fail. Between these surfaces two full pods with 12.1, 23.5, and 39.5 percents moisture level were putted and kinetic coefficient of friction was calculated with (5).

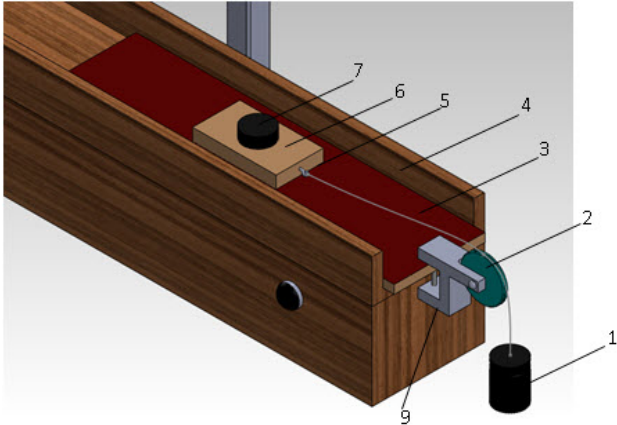

Fig. 3 Friction device 1. Weight 2. Pulley 3. Lower wooden plate 4. Desk 5. Pod place 6. Upper wooden plate 7. Extra weight

According to Fig. 4 for moving mass number 1 (3) is used; and according to Fig. 5 for moving plate and the loaded mass (4) is used.

$$mg - T = ma \tag{3}$$

$$T - \mu_k F_N = (m_1 + m_2)a \tag{4}$$

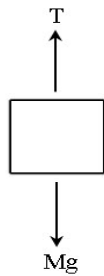

Fig. 4 Weight motion

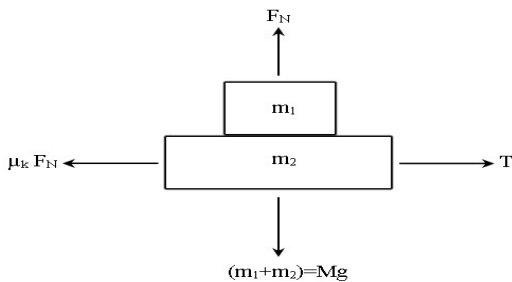

Fig. 5 Extra weight and upper wood motion

According to (3) and (4) kinetic coefficient of friction between the involved surfaces is calculated:

$$\mu_k = [mg - (m + M)a] / Mg \tag{5}$$

where, Extra mass(g) = m_2 , Upper wood mass (g)= m_1 , $M = m_1 + m_2$, kinetic coefficient of friction= μ_k , Acceleration of system ($m.s^{-2}$)= a , $g = 9.8 (m.s^{-2})$, Weight of

mass $l = m$

The acceleration of system calculated from (6):

$$x = \frac{1}{2}at^2 \tag{6}$$

where, Time (s)= t , Acceleration of system ($m.s^{-2}$)= a

Finally, kinetic coefficient of friction obtained 0.257, 0.303 and 0.336 for amount of 12.1, 23.5 and 39.5 % moisture content, respectively. By the amount of kinetic coefficient of friction and base on work and energy, from (7) energy levels of 0.784, 0.930 and 1.351 J were calculated.

$$U = \mu_k N x \tag{7}$$

where, $U =$ energy, $N =$ equal mass of M and $x =$ distance moving.

In the experiment, two pods were placed between both wooden corrugated plates and the above energy was applied to separate the soybean pods by friction force. Weights of separated pods were divided to the initial weight to calculate the percent of threshing due to friction. Completely randomized design (CRD) was used to analyze the data by SAS software.

III. RESULTS AND DISCUSSION

A. Impact Test

Table I shows results of a variance analysis for percent of pea seeds threshing under different energy and primary moisture for impact test. Effect of energy and moisture on percent of threshing in probability level of 1% is significant. Table I also shows that interaction effect of moisture and energy on threshing is not significant for impact test.

TABLE I
VARIANCE ANALYSIS OF THRESHING PEA POD UNDER DIFFERENT ENERGY AND PRIMARY MOISTURES (IMPACT TEST)

Source of variation	Degrees of freedom	Sum of squares	Mean square	F value
Moisture (Mc)	2	4260.2	2130.1	2.71 **
Energy (J)	2	2074.1	1037.1	15.92**
J × Mc	4	162.9	40.7	0.63 ^{ns}
Error	18	1172.2	65.1	

**Significant in statistic level of 1 % and ns not significant.

Fig. 6 shows threshing will increase by increasing in energy levels. Also, Fig. 7 shows threshing will increase by increasing in moisture levels.

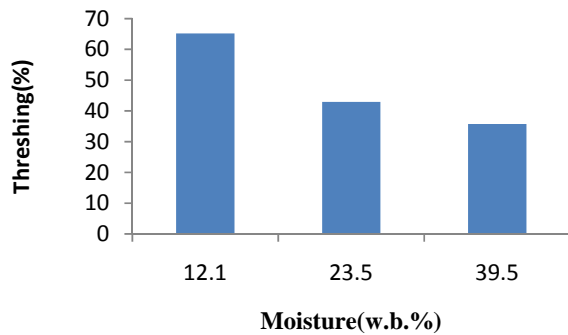

Fig. 6 Effects of moisture on threshing of pea pod in impact test

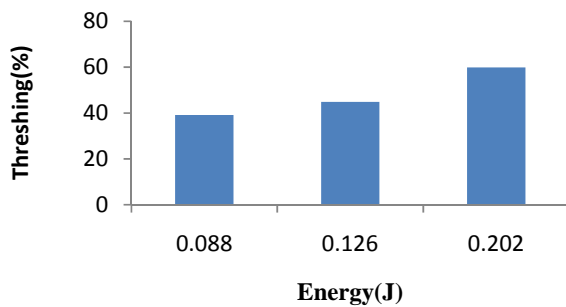

Fig. 7 Effects of energy on threshing of pea pod in impact test

B. Friction Test

Table II shows results of a variance analysis for percent of pea seeds threshing under different energy and primary moisture for friction test. Effect of energy and moisture on percent of threshing in probability level of 1% is significant. Table II also shows that interaction effect of moisture and energy on threshing in probability level of 1% is significant for friction test. In order to study two way effect of different factors on threshing of grains, compare of mean was done by LSD method, hereby, compare of mean energy levels in each level of moisture and compare of mean different moisture level in each level of energy was done separately and results presented in Table III.

TABLE II
VARIANCE ANALYSIS OF THRESHING PEA POD UNDER DIFFERENT ENERGY AND PRIMARY MOISTURES (FRICTION TEST)

Source of variation	Degrees of freedom	Sum of squares	Mean square	F value
Moisture (Mc)	2	1800.5	900.2	23.3 **
Energy (J)	2	3390.2	1695.1	43.84 **
J × Mc	4	745.8	186.5	4.82 **
Error	18	696.1	38.7	

**Significant statistical level of 1%.

TABLE III
ENERGY AND MOISTURE COMPARE OF MEAN ON THE PERCENT OF PEA POD THRESHING (FRICTION TEST).

Moisture (w.b.%)			Energy (J)
12.1	23.5	39.5	
31.2 ^{Ba}	25.1 ^{Bab}	13.1 ^{Cb}	0.784
54.9 ^{Aa}	45.1 ^{Aa}	27.1 ^{Bb}	0.980
63.4 ^{Aa}	43.3 ^{Aa}	42.3 ^{Aa}	1.351

* Same capital letters in each column and same small letters in each row show not significant different (LSD 1%).

According to Table III in 12.1 and 23.5 % moistures, there was significant different of threshing between 0.784 J energy level and other levels of energy. In this moisture levels threshing will increase by increasing in energy levels and there was significant different of threshing between all of energy levels in moisture content of 39.5%. Also according to Table III in energy levels of 0.784 and 0.980 J there was significant different of threshing between 39.5% moisture level and other levels of moisture contents. In these energy levels threshing will increase by decreasing in moisture levels. There wasn't significant different of threshing between levels of moisture contents in energy level of 1.351J. It means that if energy is very high, increasing in moisture doesn't have any effect on the amount of threshing. Also it was observed that maximum threshing in 12.1% moisture and 1.351 J energy was 63.4%. Minimum threshing in 39.5% moisture and 0.784 J energy was 13.1%.

Fig. 8 shows the effects of different energy on threshing of pod at different primary moisture content with friction test. By increasing energy and decreasing moisture, pod threshing increased in all three moisture content levels.

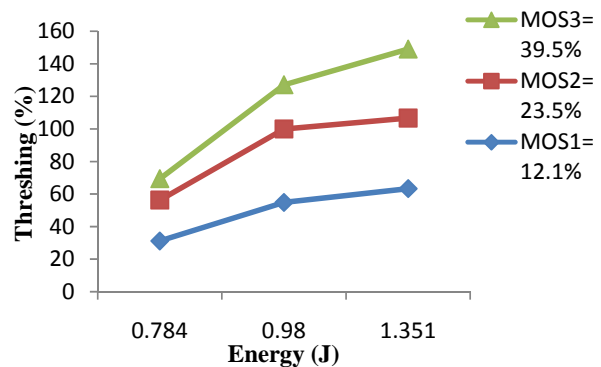

Fig. 8 Effects of energy on threshing pea pod in different moisture at friction test

The results of this paper are in agreement with the findings of other research workers. Reference [3] for threshing of soybean pods showed that maximum threshing was at minimum moisture content and maximum energy level, which was 83.4%, and the least threshing was at maximum moisture content and minimum energy level was 3.3%. The relation between moisture and energy for threshing of beans was found by impact and friction methods [8], they found that in both methods probability of breaking the pods vary with moisture, and breaking them with high moisture is more difficult.

Impact testes on bean pods showed that dry pods need less energy than wet pod to break, and pods with 13.3 and 15.3% moisture completely break and beans get out of the pods. But pods with 17.3% moisture, crack slowly and with 18.4% moisture never break. In impact method needed energy for threshing, was reported between 0.09 to 0.015 J and in friction method it was between 0.21 to 0.48 J. In friction experiments, they realized that pods with 13.3% moisture completely opened and beans get out of the pods, in 17.3% moisture, beans were still in the pods (pods just open) and in 18.4% moisture, beans never get out of the pods. In friction testes they found that friction coefficient between pods increased with increase of moisture. Researcher, was shown that soybean pod with moisture content of 10%, had good threshing action and in this moisture content the seeds ejected from pod was about 93%, also with moisture content of 16 and 21%, threshing action reduce to 90 and 79%, respectively. They reported that 0.12 J energy is needed for threshing pea pod [12]. Results of an experiment by ballistic pendulum showed by reducing the moisture content of the soybean pods, the amount of breaking energy of pod will reduce [13]. Pea pod with moisture content between 10 to 15% needed energy for threshing was 0.013 to 0.018 J [13].

IV. CONCLUSION

Needed energy for pod threshing with the two testes was increased when its moisture content was increased. By increasing impact and friction energy, amount of pod threshing increased. Also in all energy levels, maximum threshing occurs at minimum moisture. The coefficient of friction between the pod increases according to their moisture content.

ACKNOWLEDGMENT

The authors are thankful to Department of Agricultural Machinery Engineering, Gorgan University of Agricultural Sciences and Natural Resources, Gorgan, Iran, for his cooperation during preparation of this manuscript.

REFERENCES

- [1] R. Andy, and P. Rudra, Introduction to statics and dynamics, E-Publishing Inc; p. 422-497. Oxford University Press, 2010.
- [2] ASAE, Agricultural engineering handbook of standard. American society of agricultural engineers, Michigan St. Joseph, 1979.
- [3] M. Azadbakht, M. H. Khoshtaghaza, B. Gobadian, and S. Minaei, Mechanical properties of soybean pod as a function of moisture content and energy, Journal of Agricultural Technology. Vol. 8(4): 1217-1228, 2012.
- [4] M. Azadbakht, E. Esmailzadeh, and A. H. Shahabi, Investigation the mechanical behavior of canola pods versus effect of impact and friction forces, Journal of Agricultural Technology. Vol. 9(5): 1035-1044, 2013.
- [5] A. Biabani, Effect of Planting Patterns (row spacing and plant to plant in row) On the green yield Pea garden (*Pisum sativum* var. Shamshiri), J. Agric. Sci. Natur. Resour., Vol. 15(5) 2008.
- [6] N. R. Branderburg, and J. K. Park, Experimental seed combine, Transactions of the ASAE 25(3): 598-602, 606, 1982.
- [7] D. F. Cain, and R. G. Holmes, Evaluation of soybean impact damage, American Society of Agricultural Engineering. Paper Number 77-1552, ASAE, St. Joseph, MI 49085, 1977.
- [8] M. E. De Simone, C. Gracia Lopez, and R. R. Figueira, Mechanical threshing dry beans pods, ASAE Meeting Presentation. No: 006066, 2000.
- [9] M. Hoki, and K. Pickett, Factors affecting mechanical damage of navy beans, Trans. Of the ASAE, 16(6): 1154-1157, 1973.
- [10] D. E. Green, L. E. Cavanah, and E. L. Pinnell, Effect of seed moisture content, field weathering, and combine cylinder speed on soybean seed quality. Crop science, 6: 7-10, 1966.
- [11] J. Khazaei, M. Behrouzilar, A. Rajabipour, and S. Mohtasebi, Effect of impact velocity, moisture content, and pod size on percentage of damaged grains and threshed pods in a finger type combine thresher. Iranian J. Agric. Sci. 34(4): 825-836, 2003.
- [12] C. M. Mesquita, and M. A. Hanna, Soybean threshing mechanics: I. Frictional rubbing by flat belt. Trans. of the ASAE, 36 (2): 275-279, 1993.
- [13] D. L. Hoag, Properties related to soybean shatter. Trans. of the ASAE 15 (3): 494-497, 1972.
- [14] N. Parkoboon, A study of abnormal seedling development in soybean as affected by threshing injury. Seed Science and Technology, 10: 495-501, 1982.
- [15] M. R. Paulsen, W.R. Nave, and L. E. Gray, Soybean seed quality as affected by impact damage. Trans. of the ASAE. 24(6):1577-1582, 1981.
- [16] L. H. Skromme, Progress report on twin rotor combine concept of rotary threshing and separation. In Proceedings of the First International Grain and Forage Harvesting Conference, 188-191, 195. St. Joseph, MI: ASAE, 1977. Anonymous, CAV distributor Type Fuel Injection Pumps, Type DPA, Instruction Book. Acton, London, W.3. Publication No, 2068/4.