

Ant Colony Optimization for Optimal Distributed Generation in Distribution Systems

I. A. Farhat

Abstract—The problem of optimal planning of multiple sources of distributed generation (DG) in distribution networks is treated in this paper using an improved Ant Colony Optimization algorithm (ACO). This objective of this problem is to determine the DG optimal size and location that in order to minimize the network real power losses. Considering the multiple sources of DG, both size and location are simultaneously optimized in a single run of the proposed ACO algorithm. The various practical constraints of the problem are taken into consideration by the problem formulation and the algorithm implementation. A radial power flow algorithm for distribution networks is adopted and applied to satisfy these constraints. To validate the proposed technique and demonstrate its effectiveness, the well-know 69-bus feeder standard test system is employed.

Keywords—About Ant Colony Optimization (ACO), Distributed Generation (DG).

I. INTRODUCTION

SINCE distributed generation (DG) was first utilized in power systems, its many advantages have been recognized. These include; improving system reliability and continuity of service, enhancing voltage and load protection sensitivity, reducing the congestion and expansion of transmission and distribution networks, reducing power losses and improving the overall system performance. On the other hand, the DG installations have some drawbacks such as harmonic injections, the necessity of configuring more sophisticated complex control designs and the risk of the potential reverse power flow in transmission and distribution networks [1]. Due to various operational and practical requirements, the importance of DG utilization in power networks is increasingly acknowledged. One of the reasons behind that is the awareness of the harmful gas emissions associated with the generation of electrical energy. This motivates the utilization of more environmentally responsible alternatives renewable energy resources. In addition, the growing open electric power market inspires more penetration of DG in power grids. These advantages of DG installation could only be accomplished through the optimal planning of size and placement. This is to decide the suitable size and where optimally select the location of the DG placement. According to the literature, the most commonly applied approach for determining the optimal DG location is choosing potential buses according to stability and sensitivity indexes.

Consequently, the majority of the buses are excluded and hence, the feasible search hyper space is narrowed significantly. The DG is generally represented as a negative power injection on the radial feeders of the distribution systems. This operation is in parallel with system and independent of the terminal bus voltage [2]. According to the standards, the distributed resources are not to regulate the voltage at the installation point [3]. One of the definitions describes DG as a source of an electric power generation directly connected either to the distribution system or to the customer side of the network [4]. Various approaches have been proposed to solve the DG optimization problem. Most of these are determinist method that applies derivative-based approaches [5]-[10], [8]. The more recently proposed are the heuristic optimization techniques that apply a population-bases search schemes [11]-[14]. In [10], a sequential quadratic programming algorithm was applied to determine the optimal size and placement of the DG. In addition to minimization of DG cost, the other objective was to reduce the power losses to a specified level. The size of the DG was limited to 40% of the peak loads. The famous 2/3 rule, which is first proposed for the capacitor placement optimization, was applied for the optimal placement of DG [9]. The venin's theorem together with a voltage sensitivity index was applied in to find the optimal DG placement and to maximize the voltage support [15]. In this regard, the real and reactive powers of the DG are adjusted for the objective function and constraints of the problem. Reference [1] proposed a primal-dual interior point method for the optimal DG placement while improving the voltage profile and power losses. A relationship between the power losses and the current injection was analyzed in terms of sensitivity to determine the optimal DG size and location in [8]. A practical system was utilized to validate the method with assuming constant power factors for the loads on a single radial feeder. In fact such an assumption is impractical and cannot be applied for different system configurations. The optimal DG placement is treated in similar approach but with different topologies in [16]. The potential bus was selected according to power generations and load distribution of the distribution network and the admittance matrix. Through the computation of the power flow twice, an analytical methodology was conducted in [7] to find the optimal DG size and placement. Sensitivity indexes are proposed and used in [17] to determine the most suitable candidate bus for installing the DG. The sensitivity indexes were also employed in [6] to minimize the power losses in addition to determining the optimal DG size and location. The typical DG problem practically deals with potential bus locations and DG sizing,

I. A. Farhat is with the Electrical and Computer Engineering Department, Al-Mergib University, Al-Khoms, Libya (phone:+218-53-2621488, PO Box: 40161, e-mail: iafarhat@elmergib.edu.ly).

which means a combination of discrete and continuous. Due to this fact, deterministic methods do not have the ability to deal with sizing and placement simultaneously. This combination, in fact, is a real challenge to all calculus-based optimization method. This opens the door widely for heuristic and population-based method to emerge. Heuristic techniques such as Particle Swarm Optimization (PSO), Genetic Algorithm (GA), Bacterial Foraging Algorithms (BFA) and Ant Colony Optimization (ACO) are getting more attraction because of their effectiveness and superiority in solving optimization problems. Their advantageous characteristics such as their generality, flexibility and simplicity make them more preferred for problems with large search space and discrete properties. An optimal power flow algorithm is employed with a GA to minimize the DG real and reactive power cost in [14]. The DG size was reduced which resulted in a significant reduction in the feasible search space. Another GA was hybridized with an optimal power flow technique for DG optimization was suggested in [13]. In this method the economic dispatch formulation was implemented to determine the deployed DG in distribution systems. The maximization of benefit/cost ratio was addressed by the optimal DG size and placement problem presented in [11]. In addition, the objective was to minimize the power losses and maintain the reliability and voltage profile within the constraints. The consequence of deciding different DG size and placement on the systems after contingency situations was discussed in [18]. The optimal DG sizing and location was the objective together with minimizing the voltage deviations from a predetermined profile. In [12], the load supply cost was reduced. The solution as selected according to the maximum reduction of the costs. The impacts of the DG on power flow, voltage regulations and power loss were analyzed in [19]. In this regard, general rules were proposed for uniformly distributed loads.

In this paper, the optimal sizing and placement of multiple DG sources are addressed. The problem is divided into two sub-problems; size and location. An improved ACO algorithm is implemented and applied to solve these two sub-problems simultaneously. The IEEE standard 69-bus feeder distribution system is utilized to test and validate the proposed algorithm. The remainder of the paper is organized as follows: Section II provides the mathematical formulation of the DG problem. In Section III, the ACO is described. Simulation results are demonstrated in Section IV. The conclusion is drawn in Section V.

II. PROBLEM FORMULATION

The optimization problem of the DG is a mixed nonlinear optimization problem. This problem consists of both discrete and continuous control variables. The objective of this problem is to determine the optimal sizing and location of the DG sources. The real power losses of the radial distribution network are also minimized as a result of the optimal DG sizing and placement.

A. Objective Function

The main objective of this problem is to minimize the real power losses of the distribution network through determining the optimal DG sizing and location. The objective function to be minimized is mathematically formulated as follows [20]:

$$\min P_{Losses} = \frac{1}{2} \sum_{i=1}^{NB} \sum_{j=1}^{NB} \Re \{ y_{ij} \} \left[|V_i|^2 + |V_j|^2 - 2|V_i||V_j| \cos \delta_{ij} \right] \quad (1)$$

where,

- $\Re(\bullet)$: real part of complex quantity
- y_{ij} : branch admittance
- NB : number of radial distribution buses
- V_i, V_j : voltages of the i^{th} and j^{th} buses
- δ_{ij} : $= \delta_i - \delta_j$

B. Constrains

The objective function is subject to a number of operational and control constraints to be satisfied. These are inequality and equality constraints including the following:

• Equality constraints

The equality constraints of this problem are the well-known power flow equations that are expressed as follows [21]:

$$P_i = |V_i| \sum_{j=1}^{NB} |V_j| |Y_{ij}| \cos(\delta_i - \delta_j - \gamma_{ij}) \quad (2)$$

$$Q_i = |V_i| \sum_{j=1}^{NB} |V_j| |Y_{ij}| \sin(\delta_i - \delta_j - \gamma_{ij}) \quad (3)$$

where,

- $|\bullet|$: magnitude of complex quantity
- P_i : net real power at the i^{th} bus
- Q_i : net reactive power at the i^{th} bus
- Y_{ij} : ij^{th} element of the admittance matrix
- γ_{ij} : angle of ij^{th} element of the admittance matrix

• Inequality constraints

The inequality constraints are the feeders' thermal limits and the substation capacity limits among other thermal design restrictions of the network. These constraints are modeled as follows:

$$\sum_{i=1}^{nDG} (P_{DG_i} + jQ_{DG_i}) \leq P_{S/S} + jQ_{S/S} \quad (4)$$

$$\max \{ S_{ij} \text{ or } S_{ji} \} \leq S_{ij_{max}} \quad (5)$$

$$nDG \leq nDG_{max} \quad (6)$$

$$|V_i^{\min}| \leq |V_i| \leq |V_i^{\max}| \quad (7)$$

$$\phi_i^{\min} \leq \phi_i \leq \phi_i^{\max} \quad (8)$$

where,

nDG : number of DG sources

P_{DG_i} : DG real power output

Q_{DG_i} : DG reactive power output

S_{ij} : apparent power flow in the ij^{th} branch

$S_{ij_{max}}$: maximum apparent power flow in the ij^{th} branch

According to the constraint of (4), the total output power of the DG sources must not be more than the power supplied by the substation. The expression in (6) suggests that the maximum number of the DGs for a distribution network is limited by a specific number. It should also be pointed out that for a given bus, only single DG can be placed. The stability criteria expressed in (7) and (8) maintain the voltage magnitude and angle of the radial distribution system within the specified levels.

III. THE PROPOSED ALGORITHM

Since it was proposed as an optimization method in 1991 by Dorigo et al. [22]-[24], ACO techniques have been attracting the attention of more researchers. The ACO algorithm is originally inspired by the biological behaviour of the ants and, specifically, their way of communication. This inspiration comes from the ability of real ants to find the shorts paths in their movement from and to their nests when searching for food. Real ants do not communicate with each other in a direct way but they exchange information through what is known as pheromones. As an optimization technique, the ACO has been successfully applied to solve various optimization problems that have discrete decision variables. The well-known travelling salesman problem is a typical example for mimicking real ants' manners in determining the best paths. These characteristics of the ACO algorithms make them very potential techniques for optimization problems and especially the discrete ones [23]-[25]. The ACO algorithm has been implemented for various discrete problems such as the unit commitment problem. Other optimization problems with continuous variables have also been solved using the ACO [26]-[29]. Ants employed by an ACO algorithm have to choose the same path guided by a chemical factor, which is the pheromone as a peculiar communication or *stigmergy*. In this chemical-like process each one of the ants marks its own solution which is associated with an amount of pheromone. Other ants then visit the solution with higher pheromone value more frequently. This pheromone value is specified by the individual cost or path distance among other problem-dependant factors. Shorter paths with lower cost would, for example, attract other ants to follow it. A colony a specific number of ants in an ACO algorithm performs the optimization iterative process. Each individual chooses a different path and comes up with different solution in the search space region. When passes through a path, an ant deposits the pheromone. This approach helps ACO algorithms avoid getting trapped in local optima. A transitional probabilistic criterion is applied in each iteration in order

enable the k^{th} ant in the colony to choose its next path as follows:

$$p_{ij} = \begin{cases} \frac{\tau_{ij}^\alpha \cdot \eta_{ij}^\beta}{\sum_{i \in T} \tau_{ij}^\alpha \cdot \eta_{ij}^\beta} & , i, j \in T \\ 0 & , otherwise \end{cases} \quad (9)$$

where,

p_{ij} : probability value of the ij^{th} path to the k^{th} ant

α, β : specified parameters of the ACS algorithm

τ_{ij} : pheromone value for the ij^{th} path of the ACO algorithm

η_{ij} : heuristic information for the ij^{th} path of the ACO algorithm

T : total number of paths currently not visited by the ant

As suggested by(9), the transition probability is determined by the pheromone and heuristics of the trail which corresponds to the individual cost of the ij^{th} path. This path is said to be accepted when higher probability value is gained as a result of high quantity of pheromone or heuristic information. Therefore, the ant which passes through the ij^{th} path has to produce higher amount of pheromones in order increase the probability of selecting the same path in the next iteration. This is expresses as the following:

$$\tau_{ij} = (1 - \rho) \cdot \tau_{ij} + \sum_{k=1}^m \Delta \tau_{ij}^k \quad (10)$$

The heuristic information in (10) is the pheromone laid by an ant passes through the ij^{th} path $\Delta \tau_{ij}^k$.

IV. SIMULATION RESULTS

The ACO algorithm is applied to determine the multiple DG planning using the IEEE standard 69-bus radial distribution system. This system consists of a single main feeder and seven laterals. The total load demand is 3802.19 MW and 2694.60 Mvar [30]. The power factor for all DG units is assumed constant and equals 0.85 lag. The system configuration is shown in Fig. 1. The number of DG units to be sized and located in this system four. The proposed ACO algorithm is implemented in MATLAB 7.8 and executed on an Intel® core™ 2 Duo 3.0 GHz personal computer. The parameters of the ACO algorithm are tuned and fixed for both test cases as shown in Table I.

TABLE I
PARAMETER TUNING FOR THE ACO ALGORITHM

Iter.	k	α	β	ρ	τ_{min}/τ_{max}
140	30	2.65	1.95	0.15	0.05/10

The selection of these values for parameters is obtained by performing a sensitivity analysis study. This study requires long time and a huge number of experimental tests. Furthermore, according to the experimental test carried out in this work, it was found out that higher values of the

pheromone evaporation would result in worse commutation. It was also found that the number β of should be less than that of α in order to gain better commutation.

The real power losses of the system before installing the DG units were computed based on the loading profile and found 221.436 kW. The optimization of the size and location of the DG is conducted so that the power losses are minimized. The optimal locations for installing the 3 Dg units are found at buses 20, 61 and 64. The optimal power ratings are 326.145, 1283.472 and 300.768 kW respectively. The power losses according to this DG sizing and placement are reduced to 14.351 kW. After installing the DG units the minimum bus voltage was recorded at bus 13 as 0.971 while the voltage angle deviation was only 0.5887. These values before the installation were 0.911 and 1.47 respectively.

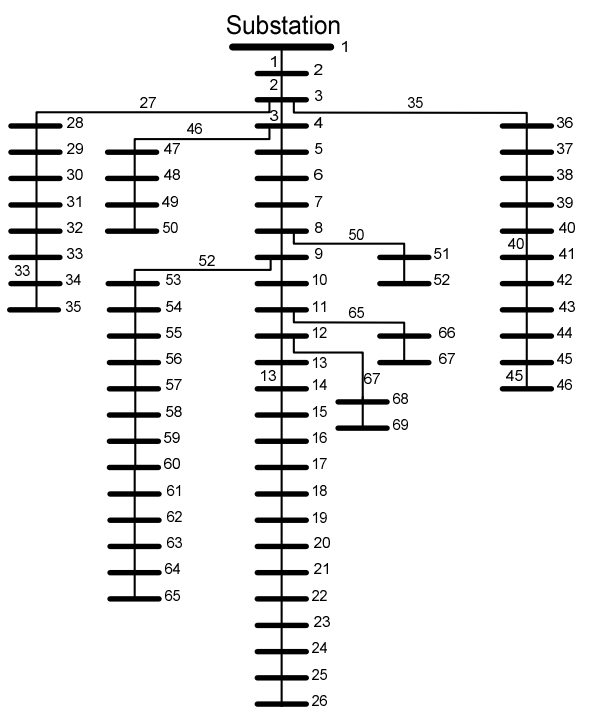

Fig. 1 69-bus radial distribution system

V. CONCLUSION

In this paper, an Ant Colony Optimization algorithm is applied to determine the optimal sizing and placement of a multiple DG sources in distribution networks. The discrete variables of the optimal DG problem make it difficult for calculus-based deterministic optimization methods. The problem consists of two parts, one is with discrete nature, which is the placement sub-problem and the other is the sizing, which has continuous variables. The proposed algorithm utilizes the power flow calculation and solves the two sub-problems simultaneously. Obtaining the optimal DG resulted in several advantages for the system such as the significant reduction in real power losses and improvement of the system voltage profile. These in turn, enhanced the system

stability and reliability.

REFERENCES

- [1] H. Iyer, S. Ray and R. Ramakumar, "Assessment of Distributed Generation Based on Voltage Profile Improvement and Line Loss Reduction," in *Transmission and Distribution Conference and Exhibition, 2005/2006 IEEE PES*, pp. 1171-1176, 2006.
- [2] C. L. T. Borges and D. M. Falcao, "Impact of distributed generation allocation and sizing on reliability, losses and voltage profile," in *Power Tech Conference Proceedings, 2003 IEEE Bologna*, pp. 5 pp. Vol.2, 2003.
- [3] Anonymous "IEEE Standard for Interconnecting Distributed Resources With Electric Power Systems," *IEEE Std 1547-2003*, pp. 0_1-16, 2003.
- [4] G. Pepermans, J. Driesen, D. Haeseldonckx, R. Belmans and W. D'haeseleer, "Distributed generation: definition, benefits and issues," *Energy Policy*, vol. 33, pp. 787-798, 4, 2005.
- [5] R. A. Jabr and B. C. Pal, "Ordinal optimisation approach for locating and sizing of distributed generation," *Generation, Transmission & Distribution, IET*, vol. 3, pp. 713-723, 2009.
- [6] T. Gözel and M. H. Hocaoglu, "An analytical method for the sizing and siting of distributed generators in radial systems," *Electr. Power Syst. Res.*, vol. 79, pp. 912-918, 6, 2009.
- [7] N. Acharya, P. Mahat and N. Mithulanathan, "An analytical approach for DG allocation in primary distribution network," *International Journal of Electrical Power & Energy Systems*, vol. 28, pp. 669-678, 12, 2006.
- [8] M. A. Kashem, A.D.T. Le, M. Negnevitsky and G. Ledwich, "Distributed generation for minimization of power losses in distribution systems," in *Power Engineering Society General Meeting, 2006. IEEE*, pp. 8 pp., 2006.
- [9] A. D. T. Le, M. A. Kashem, M. Negnevitsky and G. Ledwich, "Maximising Voltage Support in Distribution Systems by Distributed Generation," in *TENCON 2005 2005 IEEE Region 10*, pp. 1-6, 2005.
- [10] A. D. T. Le, M. A. Kashem, M. Negnevitsky and G. Ledwich, "Optimal Distributed Generation Parameters for Reducing Losses with Economic Consideration," in *Power Engineering Society General Meeting, 2007. IEEE*, pp. 1-8, 2007.
- [11] C. L. T. Borges and D. M. Falcao, "Optimal distributed generation allocation for reliability, losses, and voltage improvement," *International Journal of Electrical Power & Energy Systems*, vol. 28, pp. 413-420, 7, 2006.
- [12] B. A. de Souza and J. M. C. de Albuquerque, "Optimal Placement of Distributed Generators Networks Using Evolutionary Programming," in *Transmission & Distribution Conference and Exposition: Latin America, 2006. TDC '06. IEEE/PES*, pp. 1-6, 2006.
- [13] G. P. Harrison, A. Piccolo, P. Siano and A. R. Wallace, "Hybrid GA and OPF evaluation of network capacity for distributed generation connections," *Electr. Power Syst. Res.*, vol. 78, pp. 392-398, 3, 2008.
- [14] M. Mardaneh and G. B. Ghahrepetian, "Siting and sizing of DG units using GA and OPF based technique," in *TENCON 2004. 2004 IEEE Region 10 Conference*, pp. 331-334 Vol. 3, 2004.
- [15] H. L. Willis, "Analytical methods and rules of thumb for modeling DG-distribution interaction," in *Power Engineering Society Summer Meeting, 2000. IEEE*, pp. 1643-1644 vol. 3, 2000.
- [16] Caisheng Wang and M.H. Nehrir, "Analytical approaches for optimal placement of distributed generation sources in power systems," *Power Systems, IEEE Transactions on*, vol. 19, pp. 2068-2076, 2004.
- [17] T. K. A. Rahman, S. R. A. Rahim and I. Musirin, "Optimal allocation and sizing of embedded generators," in *Power and Energy Conference, 2004. PECon 2004. Proceedings. National*, pp. 288-294, 2004.
- [18] S. Kotamarty, S. Khushalani and N. Schulz, "Impact of distributed generation on distribution contingency analysis," *Electr. Power Syst. Res.*, vol. 78, pp. 1537-1545, 9, 2008.
- [19] Y. Baghzouz, "General rules for distributed generation - feeder interaction," in *Power Engineering Society General Meeting, 2006. IEEE*, pp. 4 pp., 2006.
- [20] M. R. Al Rashidi and M. F. Al Hajri, "Proper planning of multiple distributed generation sources using heuristic approach," in *Modeling, Simulation and Applied Optimization (ICMSAO), 2011 4th International Conference on*, pp. 1-5, 2011.
- [21] A. J. Wood and B. F. Wollenberg, *Power Generation Operation and Control*, New York, USA: John Wiley & Sons, Inc., 1996, pp. 592.

- [22] M. Dorigo, V. Maniezzo, and A. Coloni, "Positive feedback as a search strategy," Dipartimento Di Elettronica - Politecnico Di Milano Technical Report., Tech. Rep. 91-016, 1991.
- [23] M. Dorigo, M. Birattari and T. Stutzle, "Ant colony optimization," Computational Intelligence Magazine, IEEE, vol. 1, pp. 28-39, 2006.
- [24] M. Dorigo, V. Maniezzo and A. Coloni, "Ant system: optimization by a colony of cooperating agents," Systems, Man, and Cybernetics, Part B: Cybernetics, IEEE Transactions on, vol. 26, pp. 29-41, 1996.
- [25] M. Dorigo and T. Stutzel, Ant Colony Optimization, The MIT Press, 2004,
- [26] L. Shi, J. Hao, J. Zhou and G. Xu, "Ant colony optimization algorithm with random perturbation behavior to the problem of optimal unit commitment with probabilistic spinning reserve determination," Electr.Power Syst.Res., vol. 69, pp. 295-303, 5. 2004.
- [27] S. Chusanapiputt, D. Nualhong, S. Jantarang and S. Phoomvuthisarn, "Unit commitment by selective self-adaptive ACO with Relativity Pheromone Updating approach," in Power Engineering Conference, 2007. IPEC 2007. International, pp. 36-41, 2007.
- [28] R. Bharathi, M. J. Kumar, D. Sunitha and S. Premalatha, "Optimization of combined economic and emission dispatch problem — A comparative study," Power Engineering Conference, 2007. IPEC 2007. International, pp. 134-139, 2007.
- [29] I. K. Yu and Y. H. Song, "A novel short-term generation scheduling technique of thermal units using ant colony search algorithms," International Journal of Electrical Power & Energy Systems, vol. 23, pp. 471-479, 8. 2001.
- [30] M. E. Baran and F. F. Wu, "Optimal capacitor placement on radial distribution systems," Power Delivery, IEEE Transactions on, vol. 4, pp. 725-734, 1989.

Ibrahim A. Farhat received his PhD degree from Dalhousie University, Halifax, Canada, the MASc. from Concordia University, Montreal, Canada and the BSc. from Tripoli University, Libya, all in electrical engineering. He was also awarded the Dalhousie University Certificate in University Teaching and Learning. Dr. Farhat is currently working as a faculty member at the Electrical and Computer Engineering Department, Al-Mergib University of Libya. He has been teaching various power system courses for about fifteen years in both Almergib University and Dalhousie University. Before teaching, he worked as an Electrical Engineering Specialist at Waha Oil Company of Libya. The author is a member of IEEE and an editorial reviewer for some conferences and journals such as the International Journal of Electrical Power and Energy Systems and the IET, generation, Transmission and Distribution. He His research interests include power system operations and planning, optimization techniques, artificial intelligence, environmental aspects of power systems and renewable energy.