

# Influence of Number Parallels Paths of a Winding on Overvoltage in the Asynchronous Motors Fed by PWM- converters

Belassel Mohand-Tahar

**Abstract**—This work is devoted to the calculation of the undulatory parameters and the study of the influence of the number parallel path of a winding on overvoltage compared to the frame and between turns (sections) in a multiterm random winding of an asynchronous motors supplied with PWM- converters.

**Keywords**—Asynchronous Motors, Parallel path, PWM-converters, Undulatory process, Undulatory parameters, Undulatory voltage

## I. INTRODUCTION

THE most common controllable ac drives are based on asynchronous motors (AM) and frequency converters (FC) with an element; the output voltages are formed by PWM, i.e., a series of rectangular pulses is created. Most modern FC employ (IGBT) with a switching frequency of 2-8 kHz. The length of the pulse front is determined by the type of converter switch and may be 0.2-1 ( $\mu\text{sec}$ ).

As we know from the theory of transient processes, supplying rectangular pulses with rapid voltage increase to an AM winding induces wave processes (WP) in the winding. The wave processes constitute a complex set of physical phenomena accompanying the appearance propagation, and rapid change in the electromagnetic field of a circuit or system. The phenomena causes considerable voltage surge in the winding, with damage to the motor insulation and impairment of the machine's strength and longevity. Moreover, with rapid increase in electric field strength at the waterfront in the insulation, the machine sustains marked electrical losses.

The many studies of wave processes in electrical machines and transformers have mainly focused on protection against lightning surges. However, we also need to consider wave phenomena in electrical machines operating together with semiconductor (FC) and investigate their influence on the insulation, so as to predict (AM) reliability and durability. Computer simulation may be used to study these phenomena, with experimental verification where possible.

One of the means of lutes against the overvoltage caused by (PMW) is the research of resistant constructions to overvoltage.

## II. CALCULATION OF THE UNDULATORY PARAMETERS

The calculation of the wavelength constants is the first stage of solving the problem and based on the known equivalent circuit (Fig.1a):

$L_s$ - is the inductance of a section, which takes into account both the self and mutual inductances of an element;

$R_s$ -is the resistance of a section, equivalent to the losses by hysteresis in steel and in the conductors, taking into account the effect of the coating;

$K_s$ - is the longitudinal capacitance of the section, i.e. the partial capacitance between the first and the last turn over the length of the winding;

$C_s$ - is the transverse capacitance of a section, i.e. partial capacitance of these conductors compared to the frame;

$G_s$ - is the active admittance of the section, equivalent to the dielectric losses in the insulation of the housing.

This calculation method will be applied for tri-phase asynchronous motor with a cage having the following characteristics:

Rated power $P_{no}$ , kW .....	3
Input voltage U, V .....	380/660
Terminals number 2p .....	4
Stator slots Z .....	36

Slot form is oval, number of turns per slot  $w=54$  and 108 respectively for  $a=1$  and  $a=2$ . This machine is made of one concentric winding with a single layer at the stator.

The calculation of the wavelength constants is the first stage of solving the problem and is based on the known equivalent circuit (Fig. 1a). The calculation procedure of these constants for the motor under considerations is described in [1]–[5] and [7].

## III. DETERMINATION OF THE UNDULATORY VOLTAGES

Analytic calculation of the voltage surges in the IM winding [1]–[7]–[8] entails the solution of the differential equation of the wave process (WP), which is written for the equivalent circuit in (Fig.1b).

The relation between the parameters of the two diagrams (Fig.1 a and b) is given:

$$L = L_s + \frac{R_s^2}{\omega^2 L_s}; \quad R = R_s + \frac{(\omega L_s)^2}{R_s} \quad (1)$$

The voltage distribution in the given circuit is described by a hyperbolic partial differential equation [1-7]:

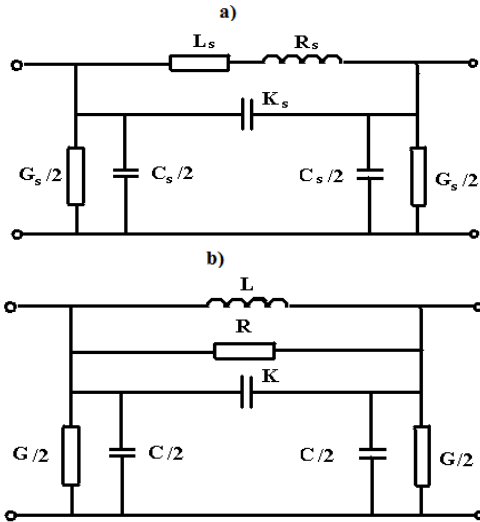

Fig. 1 Equivalent circuit of one winding coil of an IM stator with the series a) and parallel connection b) of  $L_s$  and  $R_s$

$$K \frac{\partial^4 u(x,t)}{\partial x^2 \partial t^2} + \frac{1}{R} \frac{\partial^3 u(x,t)}{\partial x^2 \partial t} + \frac{1}{L} \frac{\partial^2 u(x,t)}{\partial x^2} - C \frac{\partial^2 u(x,t)}{\partial t^2} - G \frac{\partial u(x,t)}{\partial t} = 0 \quad (2)$$

Here the  $x$ -coordinates vary continuously in the range  $0 \leq x \leq l$ ;  $l$  – is the length of the conductors in the parallel branch of the phase winding. Variation in  $x$  in the opposite direction to the incident wave motion, i.e., from the end of the winding ( $x = 0$ ) to its beginning ( $x = l$ ), is assumed to be positive.

All the parameters in the equation are referred to unit length.

Therefore, the dimensions of the parameters are as follows:

- for the longitudinal branch:
  - the inductance  $[L] = \text{H/m}$ ;
  - the resistance  $[R] = \text{Ohm/m}$ ;
  - the longitudinal capacitance  $[K] = \text{F}\cdot\text{m}$ .
- for the transverse branch:
  - the transversal capacitance  $[C] = \text{F/m}$ ;
  - the conductivity  $[G] = 1 / \text{Ohm}\cdot\text{m}$ .

The equation is solved by the Fourier method. To this end, the initial and boundary conditions determining the physical characteristics of the phenomena in the winding are preliminary specified. They are formulated as follows: a voltage wave characterized by the following equation is incident at the winding.

$$u_{pul} = U(e^{-\alpha t} - e^{-\beta t}) \text{ when } t > 0 \quad (3)$$

where  $U = 10$  (V) – is the pulse amplitude;  $\alpha$  and  $\beta$  – are constants:  $\alpha = 1.2 \cdot 10^6$  ( $\text{sec}^{-1}$ ),  $\beta = 2 \cdot 10^6$  ( $\text{sec}^{-1}$ ).

Zero initial conditions are assumed. The state is characterized by the following equation.

$$\frac{\partial^3(u,0)}{\partial^2 x \partial t} = \gamma^2 \frac{\partial u(x,0)}{\partial t} \quad (4)$$

where  $\gamma = \sqrt{C/K}$

The ends of the winding are insulated, with following boundary conditions:

- for the ends of the winding ( $x = l$ ):  $U(l,t) = u_{pul}(t)$
- for the ends of the winding ( $x = 0$ ).

$$\frac{\partial u(0,t)}{\partial x} = 0 \quad (5)$$

It should be noted that while solving the differential equation «(2)», by Fourier's method, the dependency of the parameters of frequency,  $R$ ,  $L$ , and  $G$  have been taken into account by using the iterative method discussed in [1] – [7] (see algorithm, (Fig.2).

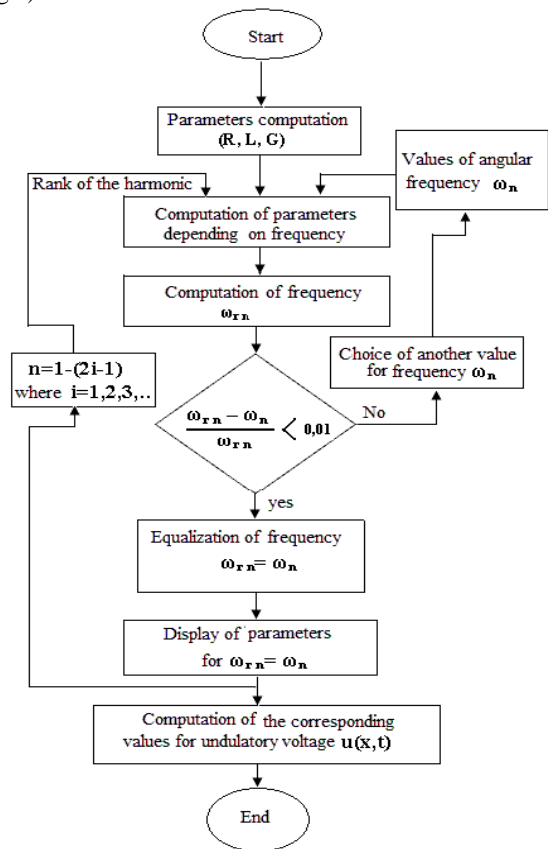

Fig. 2 Calculation algorithm for oscillatory voltages

IV. COMPUTATION RESULTS OF THE UNDULATORY PARAMETERS AND OVERVOLTAGES

Computation results of the parameters  $C_s$  and  $K_s$  without considering their variation according to the frequency and  $G_s$ ,  $L_s$ ,  $R_s$ , for a frequency of 200 kHz.

The numerical values of these parameters for the parallel paths numbers,  $a=1$  and  $a=2$  are given on the table I.

TABLE I  
NUMERICAL VALUES FOR THE UNDULATORY PARAMETERS

Parameters	Number of parallel Paths of a Winding	
	a=1	a=2
$C_s, \text{pF}$	1085	1085
$K_s, \text{pF}$	10,44	5,173
$G_s, 1/\Omega$	$3,25 \cdot 10^{-5}$	$3,25 \cdot 10^{-5}$
$R_s, \Omega$	173,92	347,6
$L_s, \mu\text{H}$	1250	2499

The computational results of the undulatory voltage, assuming that the windings is supplied with a similar impulsion as for an impulsion generated by a PWM control equipped with IGBT transistors are shown in figures 3, 4 and 5, for various values number of parallel branches winding . Figure 3, represents the undulatory process on the neutral of winding, Figure 4. gives (WP) on the first and the last section of a winding and Fig.5. presents the voltage distribution for every six turns along the parallel path for two points in times:  $t=3 \cdot 10^{-7}$  (sec) and  $t=1,2 \cdot 10^{-6}$  (sec).

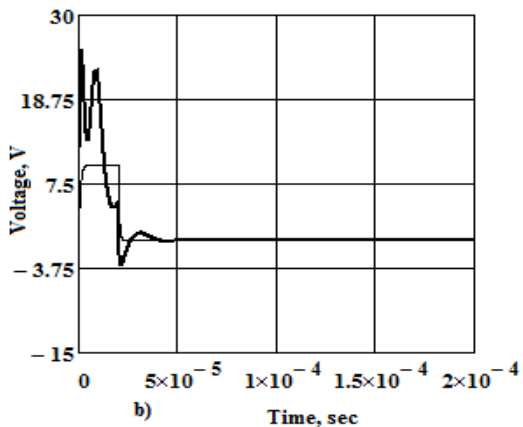
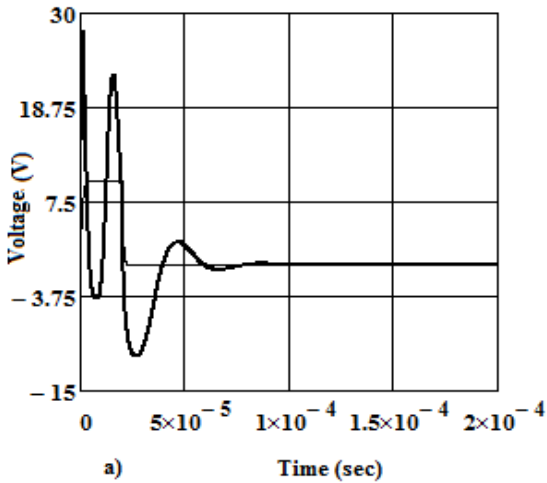

Fig. 3 Wave process in the winding phase of the motor  
 — Applied impulse in the winding  
 — Applied impulse in the winding  
 a) a = 1; b) a = 2

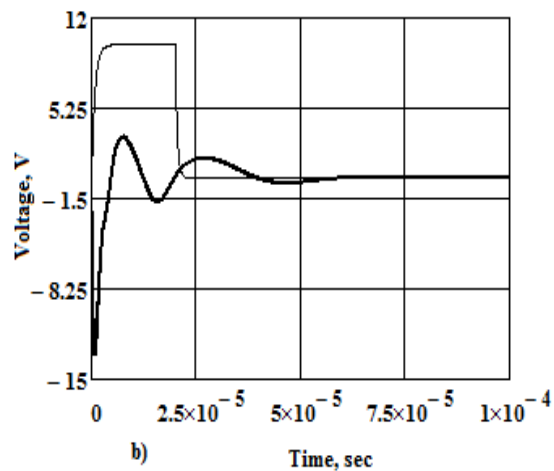
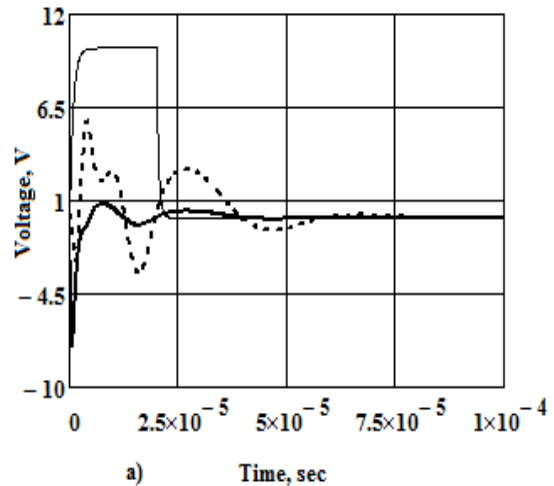
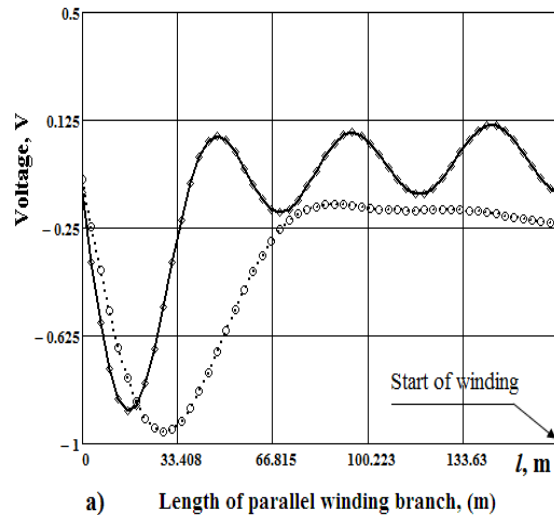

Fig. 3 Wave process in the winding phase of the motor  
 — Applied impulse on the phase  
 — Tension on the first section of the winding  
 - - - Tension on the last section of the winding  
 a) a = 1; b) a = 2



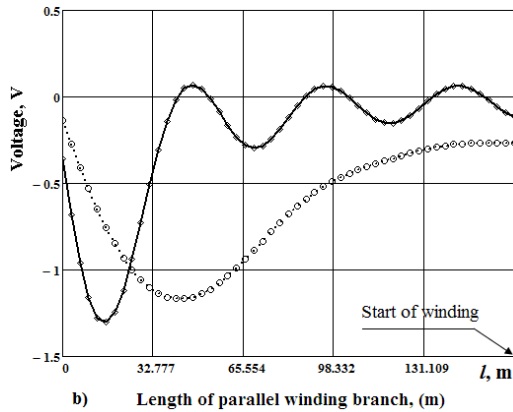

Fig. 5 Distribution of voltage through every six turns along the parallel paths of a winding for two points in times

↔  $t=3.10^{-7}$  s, ○○○○  $t= 1,2.10^{-6}$  s  
a) a =1; b) a =2.

### V.CONCLUSION

- 1) The arrival of a rectangular impulsion voltage similar to the one of a PWM variable frequency control in an asynchronous motor winding will trigger in the winding an undulatory process. By treating several cases, one notices that the overvoltage calculated with this method exceeds twice the voltage applied initially and the process at any point of the winding has a deadened oscillatory character (fig. 3).
- 2) Fig. 3 Shows that overvoltages compared to the frame fall with increase in the number of parallel path.
- 3) The results of simulation obtained show that the overvoltage between turns (sections) in a multiturn winding decreased considerably with the decrease of the number of the parallel path of a winding (fig. 4 and 5).
- 4) It can be seen from Fig. 5 that the voltage distribution at section and turns along the parallel path at the different points in time becomes more uniform with the increase in the time of the undulatory process.
- 5) The presented calculation procedure for wave-length constants and overvoltage's in the pulls supply broadens
- 6) The possibilities of investigation and the design of an insulation system for variable-speed drives and allows the choice for much correct values for interturn test voltages.

### REFERENCES

- [1] BELASSEL M-T. "The effect of the Thickness of Electrical sheet on Overvoltage in the Asynchronous Motors Fed by PWM- converters", Waset, ISSUE 73. JANUARY 2011, pp.668.
- [2] M.T Belassel and V.YA Bepalov. . "High-frequency parameters and voltage surges between the whorls of flexible winding to several winding of induction motors, fed by PMW", Electrotechnika., no.7, 2008, pp. 14-17.
- [3] M.T Belassel and V.YA Bepalov. "High-frequency parameters and voltage surges in different types windings of induction motors fed by PWM", Electrotechnika., no. 3, 2006, pp. 56-63.
- [4] M.T Belassel., Bepalov V.YA. and Chetate Boukhemis. "Capacitive parameters and voltage surges in the winding of an asynchronous motor with power supply from a PWM- converter", Electrotechnika. no .1, 2005, pp. 44-48,.
- [5] M.T. BELASSEL. "Calculation of over voltages in the Asynchronous Motors Supplied with Frequency converters of the type Modulation of

Impulsion Breadth (PWM)", 16 th International Conference on the Computation of Electromagnetic Fields «Compumag 2007» June 24-28, 2007 Aachen, Germany.

- [6] Boukhemis Chetate, Mohand-Tahar Belassel, Stéphane Simard and Rachid Beguenane, "Influence of Overvoltages in Induction Motors fed by PWM voltage inverters on Power efficiency", Electrical Power Conference, 2007. EPC 2007. IEEE Canada Number: 10052327, pp. 399-404.
- [7] Kaganov Z.G. "Electrical circuit with distributed parameters and chain circuits", Energoatomizdat, Moscow, 1990.
- [8] Vataev A.C. "High frequency electromagnetic process and overvoltages in the squirrel cage induction motors, supplied with the frequency converters", PHD, Saint Petersburg, 2009, Russia.