

Comparison of Proportional Control and Fuzzy Logic Control to Develop an Ideal Thermoelectric Renal Hypothermia System

Hakan Işık, Esra Saraçoğlu

Abstract—In this study, a comparison of two control methods, Proportional Control (PC) and Fuzzy Logic Control (FLC), which have been used to develop an ideal thermoelectric renal hypothermia system in order to use in renal surgery, has been carried out. Since the most important issues in long-lasting parenchymatous renal surgery are to provide an operation medium free of blood and to prevent renal dysfunction in the postoperative period, control of the temperature has become very important in renal surgery. The final product is seriously affected from the changes in temperature, therefore, it is necessary to reach some desired temperature points quickly and avoid large overshoot. PIC16F877 microcontroller has been used as controller for both of these two methods. Each control method can simply ensure extra renal hypothermia in the targeted way. But investigation of advantages and disadvantages of every control method to each other is aimed and carried out by the experimental implementations. Shortly, investigation of the most appropriate method to use for development of system and that can be applied to people safely in the future, has been performed. In this sense, experimental results show that fuzzy logic control gives out more reliable responses and efficient performance.

Keywords—renal hypothermia, renal cooling, temperature control, proportional control fuzzy logic control

I. INTRODUCTION

THE development of refined techniques and more advanced instrumentation has facilitated complex laparoscopic procedures such as partial nephrectomy (LPN), renal revascularization, renal autotransplantation, and the repair of abdominal aortic aneurysm (AAA). These procedures are technically challenging and can require prolonged periods of renal warm ischaemia (WI). During open surgery, renal hypothermia is frequently used to lower the metabolic rate and protect renal function during prolonged ischaemic intervals. Renal hypothermia permits up to 3 h of ischaemia with no permanent loss of renal function [1].

Renal ischaemia times remain a limiting factor in the ability to laparoscopically manage more complex renal tumours, renovascular disease, and many AAAs. Proposed methods of laparoscopic renal hypothermia are often cumbersome, can compromise exposure, and can have limited applications or unconfirmed clinical benefits. Efficient renal hypothermia would permit more adequate time for complex laparoscopic procedures that require prolonged renal ischaemia. Therefore, the development of efficient renal cooling techniques remains a focus of laparoscopic research [1].

The most important issues in long-lasting parenchymatous renal surgery are to provide an operation medium free of blood and to prevent renal dysfunction in the postoperative period. The method most easily used for this purpose is clamping the renal artery. But the disadvantage of this system is to be limited to 30 minutes time duration for not to have any functional loss in kidney [2]. It was found that warm ischaemia for over 30 minutes leads to renal dysfunction. Certainly, the effect is more likely to be permanent if the warm ischaemia period exceeds 30 min. Hypothermia induces short-term suspension of renal metabolism, which is necessary for cellular protection and for minimizing post-ischaemic renal injury. Thus renal hypothermia is necessary in patients when the warm ischaemia period is expected to exceed 30 min [3].

Recent studies about renal surgery are in search of a bloodless and long-lasting method that does not cause renal dysfunction. This can be achieved by working in a hypothermic setting [4] The major aim of this study is to investigate the methods that we have used for keeping the targeted temperature value at a certain part of the kidney and to develop a non-invasive renal hypothermia system to create an ideal hypothermia setting in distant parts of the cortex and medulla renalis. These methodologies are; Proportional Control and Fuzzy Logic Control, consequently.

Temperature control is an important factor in many process control systems. If the temperature is too high or too low, the final product is seriously affected. So, it is necessary to reach some desired temperature points quickly and avoid large overshoot. Since the process-control systems are often nonlinear and tend to change in an unpredictable way, they are not easy to control accurately [5]. This is one of many reasons why the temperature controls have advanced from simple ON/OFF controllers to more advanced microprocessor based controls and why that the control algorithm has also changed. The algorithms have gone from just providing Proportional control to what we call Fuzzy Logic control. At this point in control technology, these control algorithms have advanced to the state here these mathematical functions are now able to closely approximate human reasoning [6].

This study has been implemented as five sections. Literature Review has been mentioned in section 2. In section 3 titled as “Implementation Methodologies”, hardware of renal hypothermia system, basis of proportional control and fuzzy logic control methods and their implementations have been explained. Experimental results have been mentioned in section 4 and conclusions have been mentioned in section 5.

II. LITERATURE REVIEW

The most important issues in long-lasting parenchymatous renal surgery are to provide an operation medium free of blood and to prevent renal dysfunction in the postoperative period. The method most easily used for this purpose is clamping the renal artery. The disadvantage of the concerned method is that it is limited to a period of 30min in order to avoid loss of function in the kidney. It was found that warm ischemia for over 30 min leads to renal dysfunction [7].

Ward established that optimal renal hypothermia was at 15°C [7]. Among the methods used for hypothermia until the present time, the one that is most frequently and easily used is situ cooling of the renal surface by external ice-slush [4]. Another method is to provide hypothermia by a cooling instrument that is put around the kidney and that completely surrounds it [4]. Besides these two, there is an invasive method of renal artery perfusion [4].

Retrograde endoscopic renal hypothermia is another method used in this field [4]. In surface hypothermia performed using the well-known classical ice-slush, it is difficult to maintain the temperature at the same value in the renal cortex. Since the ice-slush in the bag rapidly warms, it is hard to ensure cooling at the same temperature and hypothermia using ice-slush method leads to renal injury [4].

In order to cool the cortex with ice-slush, a volume of about 300–750 cc is required. This leaves 5–20 min of time to manipulation. Besides, 15min should be allowed to the kidney to cool down. This procedure leads to loss of temperature in the tissues in the vicinity of the kidney, contacting with the ice-slush [4].

Retrograde endoscopic renal hypothermia is yet another method of hypothermia. Cold saline is cooled down to -1.7°C and is circulated by the retrograde urethral route. Cooling of the kidney within the classical ice bag decreases the temperature in the cortex. Researchers compared and contrasted ice-cold saline circulated by retrograde urethral instrumentation and traditional ice-slush cooling methods after renal artery occlusion [4].

One of the studies aiming to provide an effective hypothermia on the renal cortical surface is the external cooling device to the kidney study conducted by Cockett in 1961 [8]. In the concerned method, the kidney is completely mobilized and a rougher device is placed outside the kidney.

The kidneys are totally mobilized in the ice-slush method and in Cockett's method and this affects the operation time. A time of 10–15 min is needed for the cooling down of the kidney and unchanging hypothermia cannot be provided to all parts of the kidney in the ice-slush method [4]. Wakabayashi *et al.* [9] introduced the technique that ice-slush can be inserted easily into the retroperitoneal space through any cylindrical device about 3 cm in diameter by enlarging the primary port site.

Recent studies about renal surgery were focused on finding a bloodless and long-lasting method that does not cause renal dysfunction and this could be achieved by working in a hypothermic setting. As mentioned before, the aim of this study was to investigate the methodologies that we have used

for keeping the targeted temperature value at a certain part of the kidney and to develop a non-invasive renal hypothermia system to create an ideal hypothermia setting in distant parts of the cortex and medulla renalis. Hence, it can be seen that our study is closely related to temperature control.

The processes that require temperature control have various unfavourable characteristics including non-linearity, dead zone time, external disturbances and so on. Current conventional approximations do not produce satisfactory temperature controls for controlling complex processes. Because they suffer from various drawbacks such as slow stabilisation, overshooting and overall slow response [10].

ON/OFF control is the simplest form of control. Here, the actuating element has only two fixed positions which are, in many cases, simply on and off. Proportional control attempts to perform better than the ON/OFF type. The proportional controller is essentially an amplifier with an adjustable gain [11]. The first big step from ON/OFF control was with the use of PID. There are many forms of PID in the control instruments of today.

Conventional PID, also called Deviation-Derivative PID, can cause a large derivative kick during some set point changes. Other problems can arise during process upsets and then how quickly a process will stabilize using this method of PID control. The problems associated with the Deviation-Derivative PID leads to the use of the PV (Process Variable)-Derivative PID action. In the PV-Derivative PID only the P and I terms are mathematically operated after the PV/SV deviation is determined. This PID algorithm may have problems in some types of applications.

There is still yet another form of PID and that is the I-PD algorithm. In this PID action only the I term is mathematically operated on the PV/SV deviation. By using the I-PD method overshoot is minimized but the response is slower than with other types of PID control.

There is one control method that uses both PV-Derivative PID and the I-PD control algorithms and it is referred to as Brilliant PID. This method will allow the setting of different types of response curves to match the process.

The alternative to Brilliant PID and its response curves is Fuzzy Logic. PID provides proven control of a process that is linear and predictable. If an upset does occur that the PID was not anticipating, then the fuzzy control will be activated and the fuzzy logic will then bring the process back into a stable condition [6].

A fuzzy system improves the relative performance of a temperature control process with respect to the conventional scheme. It compensates non-linear errors, accelerates the response and reduces the steady-state error. The fuzzy logic controller is also able to bring keep the temperature constant at the desired value regardless of changes in the load or environment [10].

Several works had been done in this area. Zhiqiang *et al.* [12] had developed a closed loop control system incorporating fuzzy logic for a class of industrial temperature control problems employing a unique fuzzy logic controller (FLC) structure with an efficient realization and a small rule. Their

study demonstrated in both software simulation and hardware test in an industrial setting that the fuzzy logic control is much more capable than the current temperature controllers. This includes compensating for thermo mass changes in the system, dealing with unknown and variable delays and operating at very different temperature setpoints without retuning. Thyagarajan et al. presented four control schemes designed using advanced techniques for regulating the temperature of the Air Heat Plant. Four control schemes namely, PID (Proportional Integral Derivative), fuzzy logic control (FLC), fuzzy logic control using genetic algorithms (FLC-GA) and neuro fuzzy control (NFC) are developed and presented. All these schemes are evaluated with respect to set-point tracking using performance indices. Their studies highlighted superiority of FLC over PID, FLC-GA over FLC and NFC over other schemes. There are also two more works utilizing fuzzy logic to control temperature for specific applications [10].

III. IMPLEMENTATION METHODOLOGIES

A. Hardware

In this section, hardware of thermoelectric renal hypothermia system has been explained. The block diagram of developed system is shown in Fig. 1.

Temperature value in the system is controlled by using 8-byte microcontroller, PIC16F877, and programmed by microcontroller MPASM package. The temperature value obtained from sensors output, feeds the microcontroller PIC16F877 (This has been used as one of the input characteristics in FLC.). A 10-byte counter that can be adjusted as four ups-downs separately between 0 and 700 is placed in PIC16F877 in order to determine the temperature value at different parts of the kidney. Thus, not only the temperature value of the area can be adjusted by its own counter, but also the thermoelectric module and the sensors that perceive the temperature of these modules can be selected

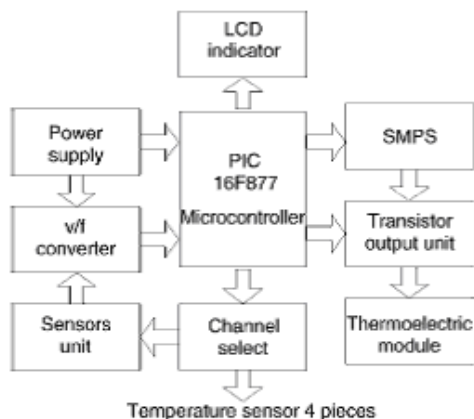

Fig. 1. Block diagram of the developed system.

A serpentine formed from a 4-mm copper tube is mounted at the opposite side of the module's surface cooling the

kidney. Water at room temperature is pumped through a plastic pipe to the serpentine, which travels along the serpentine and returns to the depot. Thus, temperature of the part of the module that functions as a cooler is stably controlled. In case that there is not sufficient water in the system or in case of sensor errors, alarm system is automatically activated and gives a sonorous warning. In addition, the type of the error can be monitored from the Liquid Crystal Display (LCD). When the temperature value in the system reaches or exceeds the warning limit, alarm system is activated. The system can readily provide the ideal temperature value of hypothermia, which is 15 ° C, in 15 min and the temperature range can be adjusted between -50 and +50°C. When the temperature of a module reaches the desired cooling value, the system can keep the same temperature value for as long as necessary

The main body of the system covers an area of 50 cm × 25 cm × 25 cm. Each module is square in shape and 4 cm × 4 cm × 0.3 cm in size. It can be used in the form of a box that can house renal poles depending on the modular position. Cooling modules can be used in two opposite sides of the kidney at the same time. Modules can be sterilized ethylene oxide gas. Schematic view and application of the developed renal hypothermia system is presented in Fig. 2.

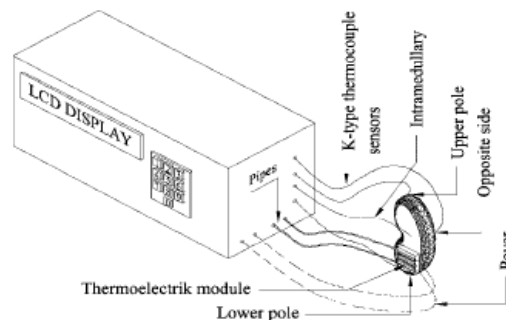

Fig. 2. External view of the developed thermoelectric renal hypothermia system.

In the following sections, design and implementation of a thermoelectric renal hypothermia system that is controlled by proportional control method and then fuzzy logic control method has been explained.

B. Proportional control

For a controller with proportional control action, the relationship between the output of the controller $u(t)$ and the actuating error signal $e(t)$ is

$$u(t) = K_p \times e(t) \tag{1}$$

or, in Laplace – transformed quantities,

$$U(s)/E(s) = K_p$$

where K_p is termed the proportional gain.

Whatever the actual mechanism may be and whatever that form of operating power, the proportional controller is essentially an amplifier with an adjustable gain. A block diagram of such a controller is shown in Figure 3 [11].

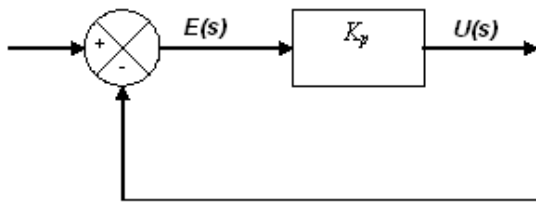

Fig. 3. Block diagram of a proportional controller [11].

C. Implementation of thermoelectric renal hypothermia system by proportional control

As it can be remembered from section 3.1.; the temperature value in the system was controlled by using 8-byte microcontroller, PIC16F877, and programmed by microcontroller MPASM package. The temperature value obtained from sensors output, feeds the microcontroller PIC16F877. And in addition to this, a 10-byte counter that can be adjusted as four ups-downs separately between 0 and 700 was placed in PIC16F877 in order to determine the temperature value at different parts of the kidney. Thus, not only the temperature value of the area could be adjusted by its own counter, but also the thermoelectric module and the sensors that perceive the temperature of these modules could be selected.

Here, microcontroller calculates the difference between the adjusted temperature value and the real temperature value that is perceived by means of the sensors. The difference is multiplied by the system's proportional gain. The proportional tension obtained in this way is used as the control tension that changes duty cycle of the Switch Mode Power Supply (SMPS). When the control tension of SMPS is proportionally altered, the outlet tension automatically changes proportionally. This tension feeds the thermoelectric module in the selected area. The system is equipped with a continuous cycle, required for cooling in thermoelectric systems. The flow chart of the program is shown in Fig. 7. The flow chart is shown in this figure in a general approach with the subroutines [4].

D. Fuzzy logic control

In this section we give a brief introduction of the fuzzy logic used here. Unlike the conventional control methods, whose effectiveness strongly relies on the accuracy of the analytic control model, fuzzy logic control is used when developing such a model is difficult or impossible. Like other control mechanisms, fuzzy logic control is essentially a feedback control system as presented in Figure 5. The object to be controlled is called the *system* is denoted as *S*. The controller, denoted as *C* is to guarantee a desired response of the output *y*, i.e., keeping the output *y*, close to the reference point *w* (keeping *e* small). The output *u*, of the controller *C*, is the control action [13].

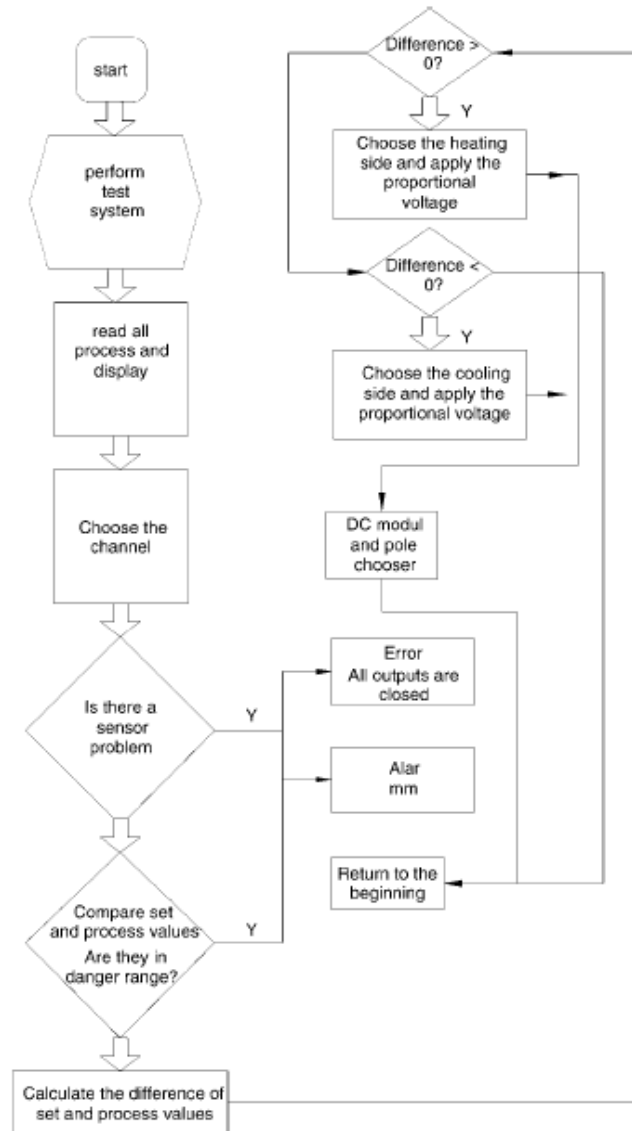

Fig. 4 Flow chart of the developed control system [4]

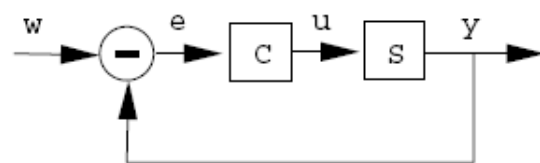

Fig. 5. A feedback control system [13]

A fuzzy controller consists of a set of rules, an inference engine, a fuzzifier and a defuzzifier. Rules may be provided by an expert (i.e. a human) or can be extracted from numerical data. The fuzzifier maps crisp numbers into fuzzy sets. Its job is to activate rules associated (through linguistic variables) with fuzzy sets. Fuzzy inference is expressed in terms of fuzzy variables that are ambiguous or imprecise. Depending on the

input values, fuzzy variables become active and the inference engine creates a fuzzy set for the output fuzzy variables. Thus inference engine maps fuzzy sets into fuzzy sets. The resulting output fuzzy set is given as input to a defuzzifier, which transforms the set into crisp numbers (i.e: a control action). The inference engine is the core of the fuzzy system which handles the way in which rules are combined, representing the knowledge base of the system [14].

a. Implementation of Thermoelectric renal hypothermia system by fuzzy logic control

The block diagram of fuzzy logic controller which has been improved for thermoelectric renal hypothermia system is seen in Figure 6.

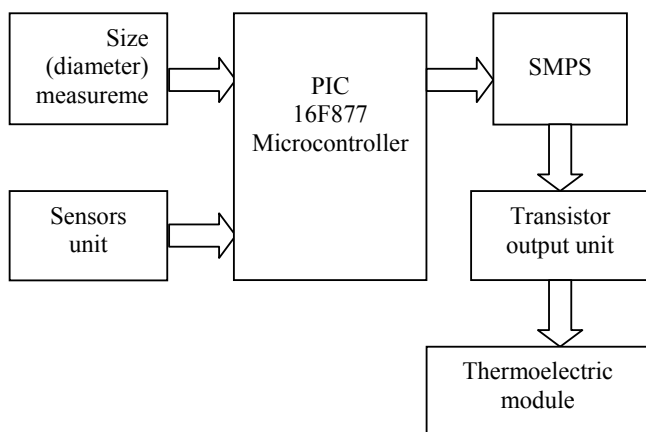

Fig. 6. Block diagram of fuzzy logic controller [15]

In Figure 6, temperature sensors and size (diameter) measurement are used to get input characteristics of the designed system. These input characteristics are delivered to PIC16F877 microcontroller. Fuzzy logic is implemented here and output of the system is determined as duty cycle of the output PWM signal of SMPS. Thus, working time of the renal hypothermia system is increased or decreased by only changing “On-position” time of the signal without changing its period, so firstly energy saving is provided. Duty cycle of SMPS changes by being interpreted the input variables by microcontroller. Change of duty cycle also effects transmission time of transistor. Transistor output is given to thermoelectric module. According to transmission time of the transistor, thermoelectric module is heated or cooled. Temperature sensors perceive consistently temperature of the zone that is heated or cooled by thermoelectric module. Sensed temperature value is given to the system as a feedback, so concerning processes are implemented by considering also a small change of kidney temperature.

The designed system has two inputs and one output. Inputs are kidney temperature and surface diameter (it is used to determine tumour size). According to values of these input variables, the system will determine “Duty Cycle” of output PWM signal. Renal hypothermia system must keep the

temperature at optimum value (15 ° C) during the operation. This is also provided by increasing or decreasing “Duty Cycle” of the output PWM signal by interpreting the input variables. Namely, time of remaining “ON” position is changed according to the input characteristics. Thus, while signal is having a fixed period, the renal hypothermia system is provided to work more efficiently. When the temperature of kidney increases, it is measured by dedicated sensor again and then the duty cycle value of output signal is increased, so the kidney is provided to be cool. Duty cycle decreases if the optimal temperature value is approached. General structure of fuzzy logic controller for thermoelectric renal hypothermia system is shown in Figure 7.

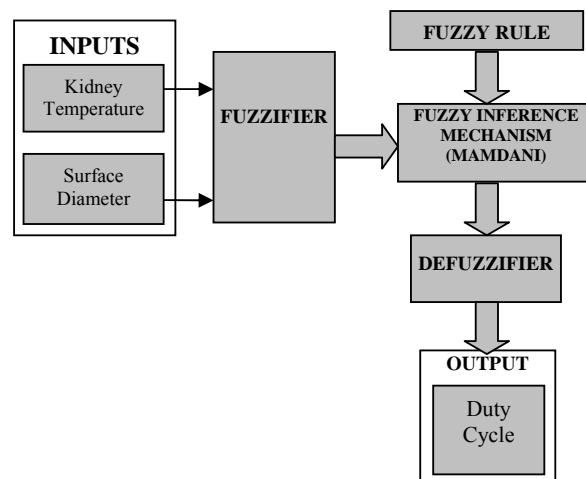

Fig.7. Structure of fuzzy logic approach for the thermoelectric renal hypothermia system [15]

Kidney temperature (°C), one of the inputs, is measured on kidney’s surface by using the concerning temperature sensor and surface diameter (mm), another input, which needs to be cooled, is measured on the surface of kidney. This parameter has been used for determining the tumour size. Output of the system is duty cycle which indicates that how many percent of a period that the signal has the maximum value. If this value is high, renal hypothermia system will cool more quickly; otherwise renal hypothermia system will cool more slowly.

In designed system, kidney temperature has been explained by using five linguistic variables while surface diameter has been explained by using four linguistic variables. So, 20 rules have been formed (5×4). Output variable duty cycle has been explained by using five linguistic variables. Mamdani has been used as inference mechanism and Mean Max Method has been used for defuzzification as it produces more successful and reliable output values. Besides, triangle membership function was preferred because of being used widely and ease of implementation. Here, fuzzy logic is implemented in the form of PIC language in PIC16F877 microcontroller. So, the ranges of input and output variables in hexadecimal code are needed. The input variables are fuzzified. After proper defuzzification using rule base and aggregation methods, the

output which is going to be used in control action was evaluated. The inference obtained from the fuzzy logic controller determines duty cycle of output PWM signal. Temperature control is provided via duty cycle. As mentioned before, only working time of output signal will change while the period of output signal stays unchanged.

Membership function graph for the input variable “Kidney Temperature” is seen in Figure 8 as an example. Five linguistic variables have been used as Low, Optimum, Close, Far and Too Far. Ranges of membership functions and additionally their ranges in hexadecimal code are shown in Table 1.

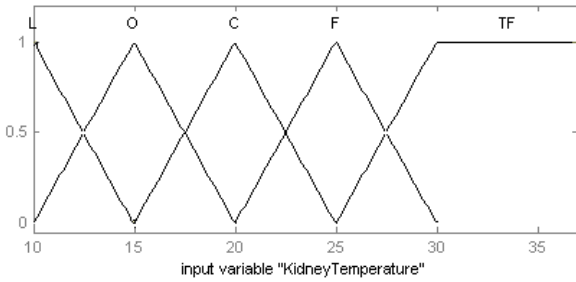

Fig. 8. Membership function for the input variable “Kidney Temperature”

TABLE I
KIDNEY TEMPERATURE (°C)

CRISP INPUT RANGE	CRISP INPUT RANGE (HEX)	FUZZY LINGUISTIC VARIABLE
10 – 15	0AH – 0FH	LOW
10 – 20	0AH – 14H	OPTIMUM
15 – 25	0FH – 19H	CLOSE
20 – 30	14H – 1EH	FAR
25 – 37	19H – 25H	TOO FAR

Ranges of membership functions for “Surface Diameter” and “Duty Cycle” and additionally, their ranges in hexadecimal code are shown in Table 2 and Table 3, consequently.

TABLE II
SURFACE DIAMETER (MM)

CRISP INPUT RANGE	CRISP INPUT RANGE (HEX)	FUZZY LINGUISTIC VARIABLE
15 – 25	0FH – 19H	NORMAL
20 – 40	14H – 28H	LARGE
30 – 50	1EH – 32H	VERY LARGE
45 – 55	2DH – 37H	VERY VERY LARGE

TABLE III
DUTY CYCLE (%)

CRISP INPUT RANGE	CRISP INPUT RANGE (HEX)	FUZZY LINGUISTIC VARIABLE
0 – 30	00H – 1EH	VERY SMALL
10 – 50	0AH – 32H	SMALL
30 – 70	1EH – 46H	MEDIUM
50 – 90	32H – 5AH	LARGE
70 – 100	46H – 64H	VERY LARGE

While forming the rule base, effect of surface diameter to duty cycle has been considered. This input variable has been used to determine tumour size. Some of the rules are demonstrated in Table 4 as examples.

TABLE IV
SOME OF RULES IN RULE BASE

Rule Number	Kidney Temperature	Surface Diameter	Duty Cycle
1	LOW	NORMAL	VERY SMALL
6	OPTIMUM	LARGE	SMALL
13	FAR	NORMAL	MEDIUM
18	TOO FAR	LARGE	LARGE
19	TOO FAR	VERY LARGE	VERY LARGE

IV. EXPERIMENTAL RESULTS

In this study, a comparison of two methods, Proportional Control and Fuzzy Logic Control, which have been used to develop a thermoelectric renal hypothermia system, has been carried out. Every developed system was tested for 60 minutes in order to provide hypothermia in the kidneys of totally ten Mongrel species, dogs at room temperature in Research and Development Laboratory of Selcuk University, Faculty of Veterinary Medicine. The dogs were anesthetized with 2 mg/kg Xylazine + 20 mg/kg ketamine hydrochloride and trans-peritoneal incisions were made. The kidneys of the dogs were determined as average to be 6.8 cm long, 4.3 cm wide and 2.9 cm thick. At the beginning of the operation renal pedicle was freed and clamped. Sensors were placed near the area that is desired to be cooled. The module was sterilized with ethylene oxide gas and it was placed at the area which is desired to be cooled.

It had been found that optimal renal hypothermia temperature is 15°C with the experiments performed by Ward (13). For this purpose, temperature of the system was adjusted to 15°C. Temperatures measured by thermocouple in the vicinity of the module were recorded. The measurements were repeated for a total of 13 times, once at the beginning and every 5 minutes thereafter. Every measurement was also repeated 10 times and their arithmetic mean was calculated so possible measurement errors were minimized. In addition,

body temperature was rectally measured every 5 minutes for 60 minutes. Obtained results are given in Table 5 and Table 6. According to the results, responses of the system with PC and

FLC are shown separately in Fig. 9 and Fig. 10, and together in Fig. 1.

TABLE V
15 °C COOLING RESULTS OF PC

Time (min)	Module Temperature (° C)
0	26.7
5	14.9
10	15.2
15	14.8
20	15.3
25	15.1
30	14.9
35	15.1
40	15.3
45	15.2
50	15.2
55	15.1
60	15.2

TABLE VI
- 15 °C COOLING RESULTS OF FLC

Time (min)	Module Temperature (° C)
0	26.7
5	17.9
10	14.9
15	15
20	15.1
25	15.1
30	14.9
35	15
40	15.1
45	15.1
50	15
55	15
60	15.1

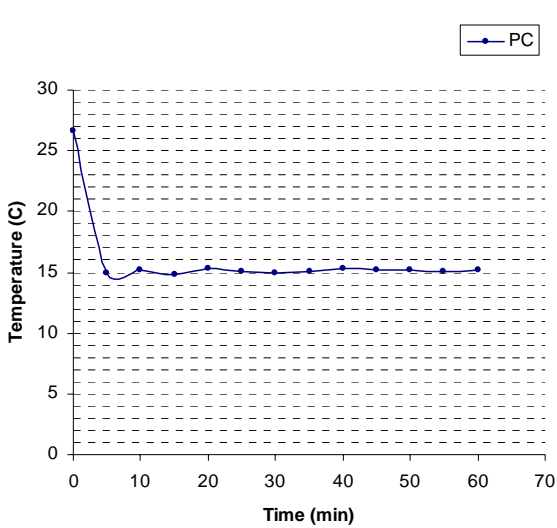

Fig.9. Response of PC

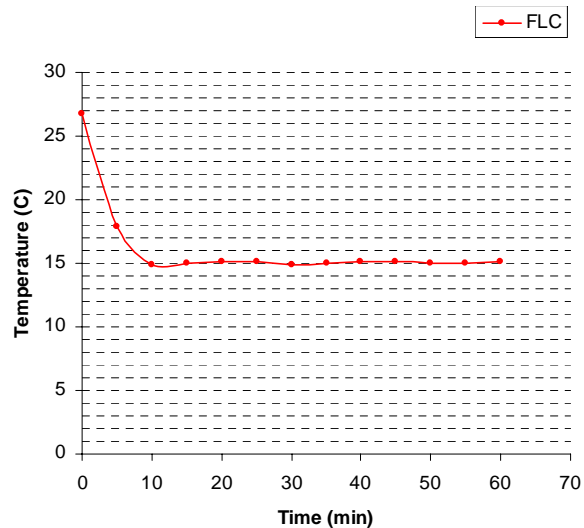

Fig.10. Response of FLC

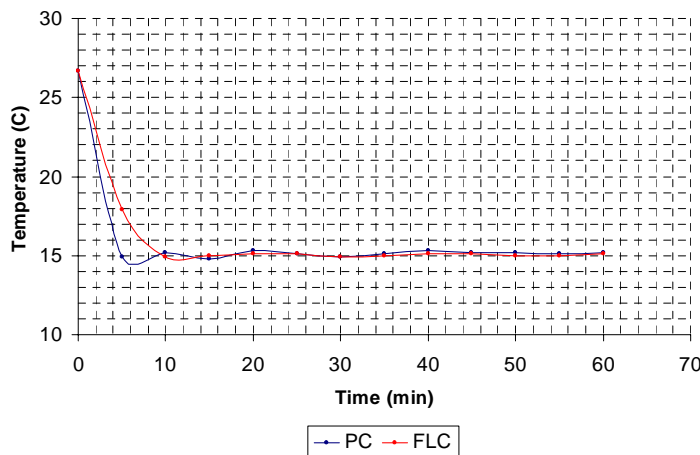

Fig.11. Responses of PC and FLC

V. CONCLUSIONS

Both of two methodologies, PC and FLC have been compared to create an ideal hypothermia setting in distant parts of the cortex and medulla renalis. For each method; the developed system behaves non-invasive and can keep targeted part of the kidney at a certain temperature for as long as necessary. Renal cortex can be cooled down to the intended temperature values, totally or locally. Cooling modules can be used in two opposite sides of the kidney at the same time. After the temperature of the module reaches the targeted cooling value, the same temperature can be stably maintained.

It is contemplated that using both of these two methods, does not only prolong the operation time, it also confers all the advantages of hypothermia. If these used two methods for the thermoelectric renal hypothermia system are compared to each other;

The thermoelectric renal hypothermia system that is developed via proportional control brings any part of the kidney to the targeted temperature in 5 min and reliably maintains that temperature value for the determined period of time. No significant temperature changes take place in other parts of the kidney and general body temperature is not affected. System usage is easy and additionally, it does not affect body temperature and does not effect to the tissues around kidneys.

The thermoelectric renal hypothermia system that is developed via fuzzy logic control brings any part of the kidney to the targeted temperature between 7 - 8 min and reliably maintains that temperature value for the determined period of time. No significant temperature changes take place in other parts of the kidney and general body temperature is not affected, either.

As it can be seen from Fig. 9, 10 and 11; FLC needs more time than PC, because of not working with a continuous cycle, but by using FLC, firstly, energy saving is provided for critical conditions like power cut and then temperature swings stay at minimum level. Besides, while forming the rule base, effect of surface diameter to duty cycle had been considered and this input variable had been used to determine tumour size. Hereby and also by getting feedback of kidney's temperature, an efficient cooling is ensured and kidney is protected from side effects. The system with FLC has been designed in order to give the optimal output value by considering these states.

In short, both of these two methods can simply ensure extra renal hypothermia in the targeted way. Additionally, they do not affect body temperature and do not effect to the tissues around kidneys. If desired, only the area of interest is cooled and can be mobilized independent of other areas. But by using fuzzy logic control method, energy saving is provided and temperature swings stay at minimum level. Also, the designed system via fuzzy logic control takes into consideration so appropriate parameters that can reflect very small changes in kidney and can be feasible to apply on people safely in the future.

REFERENCES

- [1] Laven, B.A.; Kasza K.E.; Rapp D.E.; Orvieto M. A.; Lyon M.B.; Oras J.J.; Beisert D. G.; Hoekt T.L.V.; Son H.; Shalhav A.L. A pilot study of ice-slurry application for inducing laparoscopic renal hypothermia, *BJU International*. 2006, 99 (1), 166-170.
- [2] Işık, H.; Sert, U.; Yavru, N.; Allahverdi, N. Microcontroller Based Hypothermia System. Proceedings of the International Conference on Computer Systems and Technologies-CompSysTech'07, June 14 – 15, Rousse, Bulgaria , 2007
- [3] Ramani, A.P.; Ryndin, I.; Lynch, A.C.; Veetil, R.T.P. Current concepts in achieving renal hypothermia during laparoscopic partial nephrectomy. *Brit. J. Urol. Intl.* 2006,97 (2), 342-344.
- [4] Isık, H. A New Microcontroller Supervised Thermoelectric Renal Hypothermia System. *J. Med. Syst.* 2005, 29 (5), 1-10.
- [5] Lin, C.J. A GA-based neural fuzzy system for temperature control, *Fuzzy Sets and Systems*. 2004, 143 (2), 311-333.
- [6] Wilkinson, J. Additional Advances in Fuzzy Logic Temperature Control Conf. Record of the 1995 IEEE Ind. Applic. Conf. 1995, 3, 2721-2725.
- [7] Ward, J.P. Determination of the optimal temperature for regional renal hypothermia during temporary renal ischemia. *Brit. J. Urol.* 1975, 47, 17-24.
- [8] Cockett, A.T.;The kidney and regional hypothermia. *Surgery.* 1961, 50, 905-910.
- [9] Wakabayashi, Y.; Narita, M.; Kim, C.J. Renal hypothermia using ice slush for retroperitoneal laparoscopic partial nephrectomy. *Urology.* 2004, 63, 773-775.
- [10] Yasin, F. M.; Tio, A.; Islam, M.S.; Reaz, M. I.; Suleiman, M.S. The Hardware Design of Temperature Controller Based on Fuzzy Logic for Industrial Application, Employing FPGA. *Microelectronics 2004, ICM 2004 Proceedings. The 16th International Conference on, IEEE, 2004, 157-160.*
- [11] Ogata K. *Modern Control Engineering*; 3rd ed. Prentice – Hall Inc: Upper Saddle River, New Jersey, 1997; 215 pp.
- [12] Zhiqiang, G.; Trautzsch, T.A.; Dawson, J.G. A stable self-tuning fuzzy logic control system for industrial temperature regulation. *IEEE Ind. Applic. Conf.* 2001, 2, 1232 – 1240.
- [13] Li, X.; Shen, H.W. Adaptive volume rendering using fuzzy logic control. *Proceeding of Joint Eurographics - IEEE TCVG symposium on visualization, Springer, Berlin, 2001.*
- [14] Kim, S. C.; Seo, H. W.; Han, H. S.; Khatib, O. Fuzzy Logic Control of A Robot Manipulator Based on Visual Servoing. *Industrial Electronics, 2001.Proceedings. ISIE 2001. IEEE International Symposium on, June 12-16, 2001, 3,1597 – 1602.*
- [15] Isık, H.; Saracoglu, E; Guler, I. Design of Fuzzy Logic Controlled Thermoelectric Renal Hypothermia System. *Instrumentation Science & Technology.* 2008, 36(1), 310 - 322.