

# Assembly and Alignment of Ship Power Plants in Modern Shipbuilding

A. O. Mikhailov and K. N. Morozov

**Abstract**—Fine alignment of main ship power plants mechanisms and shaft lines provides long-term and failure-free performance of propulsion system while fast and high-quality installation of mechanisms and shaft lines decreases common labor intensity. For checking shaft line allowed stress and setting its alignment it is required to perform calculations considering various stages of life cycle. In 2012 JSC SSTC developed special software complex “Shaftline” for calculation of alignment of having its own I/O interface and display of shaft line 3D model. Alignment of shaft line as per bearing loads is rather labor-intensive procedure. In order to decrease its duration, JSC SSTC developed automated alignment system from ship power plants mechanisms. System operation principle is based on automatic simulation of design load on bearings. Initial data for shaft line alignment can be exported to automated alignment system from PC “Shaft line”.

**Keywords**—ANSYS, propulsion shaft, shaftline alignment, ship power plants.

## I. INTRODUCTION

**P**RECISE alignment of main mechanisms of ship power plants and shaft lines provides long and trouble-free operation of ship propulsion system while fast and high-quality installation of mechanisms and shaft lines onboard the ship reduces its overall labor intensity.

Calculation of alignment parameters is essential part of documentation developed in course of ship construction. Loads on bearings, tensions in shaft lines and deflection curves defined by calculations directly affect operation reliability of ship propulsion system. Such calculations are mainly performed by special software. This software is used by many classification societies [1] as well as by companies specializing in manufacturing and construction of propulsion systems [2].

In order to calculate alignment parameters of ship shaft lines, JSC SSTC has developed special software “Valoprovod” with integrated I/O interface, and display of shaft line 3D model. Calculation module functions are performed by ANSYS [3], [4] complex using general finite elements analysis method and having wide capabilities in structural analysis. This program is able to generate shaft line of almost any complexity upon availability of comprehensive data regarding its loads and geometrical parameters.

A. O. Mikhailov is with the Shipbuilding& Shiprepair Technology Center, Saint-Petersburg 198095 Russia (e-mail: info@sstc.spb.ru).

K. N. Morozov is with the Shipbuilding& Shiprepair Technology Center, Saint-Petersburg 198095 Russia (e-mail: info@sstc.spb.ru).

Calculation of shaft line alignment parameters starts from composition of structural model (as per shaft line drawings) which considers:

- Geometrical parameters of shaft line components;
- Materials properties of shaft lines, propellers and anti-friction bearing inserts;
- External loads and moments affecting shaft line;
- Position of bearings in relation to shaft line reference axis;
- Bearing inserts parameters;
- Submersion of shaft line part into water

Structural model injected in program is composed from elements with constant geometrical parameters and loads.

Material properties of shaft line components and environmental conditions are injected from integrated material database.

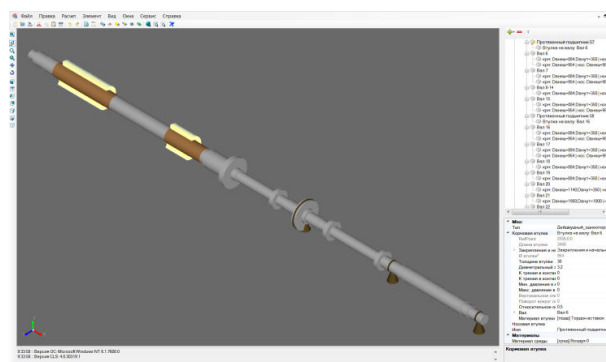

Fig. 1 Interface of “Valoprovod” software

After generation of shaftline structural model, the program creates database file and launches ANSYS program in batch mode. Calculation time for 1 object varies from 1 to 10 minutes depending on structural model complexity. This program allows to work with object in different states/conditions: ship located at slip/afloat, loaded/unloaded, etc. Various conditions are generated in project tree, all calculation results can be displayed simultaneously.

Calculation results are displayed in form of graphs, epures and 3D images of contact pressure distribution in shaft line bearing inserts. Calculation results allow to evaluate:

- Tensions in shaftlines (normal, shear, equal);
- Shaft line deflection curve parameters (deflection, cross-sections rotating angle),
- Distribution of pressure along shaft line surface and bearing inserts.

In case extra depth of analysis is required, one can open project file directly in ANSYS.

Upon analysis of calculation results, the alignment parameters get optimized. This is aimed to:

- Meet requirements of suppliers of bearings, gearboxes and main propulsion units regarding their alignment and assembly;
- Achieve optimal tensions in shaft lines;
- Achieve equal distribution of contact pressures in shaft line bearing inserts.

The optimization is performed by changing position of shaft line supports.

This program can automatically optimize contact pressures in shaft line bearing inserts. After operation mode startup, bearings rotate automatically in accordance with natural shaft line curve.

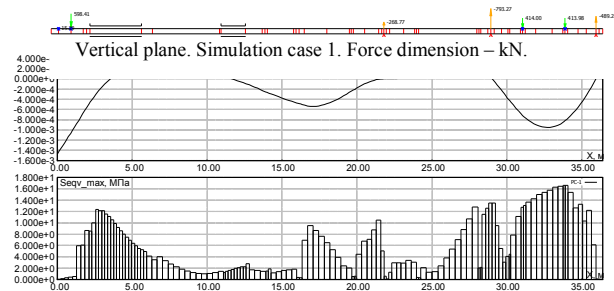

Fig. 2 Diagram and epure showing shaft line deflection curve and maximum equal tensions in shaft lines accordingly

Simulation case 1. Sample 1.

Simulation case 1. Sample 2.

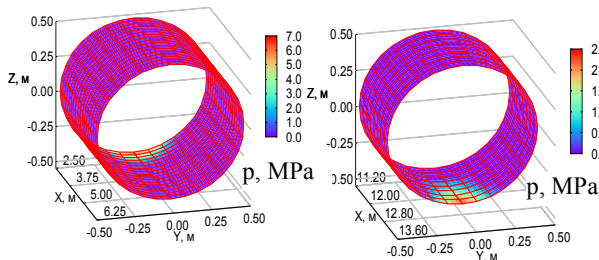

Fig. 1 Distribution of contact pressures in bearing inserts

At the present time, “Valoprovod” software is under approval procedure in RMRS.

Alignment of ship power plants and shaftlines is purposed to provide long-term successful operation of propulsion complex, while fast and qualitative mount of machinery and shaftlines onboard the ship reduces labor intensity of shipbuilding.

The most common procedure of multi-support shaftlines alignment is alignment by bearing loads [5], [6]. The core of this procedure is appliance of design loads on shaftline supports. For alignment mechanical and hydraulic jacks and dynamometers are used. Mechanical disc spring dynamometers are of simple design and easy in use, but measurement errors can be significant (up to 10%). Hydraulic

jacks are more precise (5%), but their accuracy can be influenced by different factors, related to hydraulic jacks design features.

Alignment of shaftline by appliance of loads on bearings is a sequence of successive iterations, purposed for appliance of pre-set load on all bearings to be aligned. So, as more supports the shaftline has, as more difficult is alignment of the same. During appliance of pre-set load on one bearing, the load transfer on other bearings takes place; alignment of multi-support shaftline can take few days.

In order to reduce time for alignment of multi-support shaftline, as well as for mounting of machinery, requiring application of stand loads, JSC SSTC developed the automated system for alignment of ship borne power plants machinery and shaft lines.

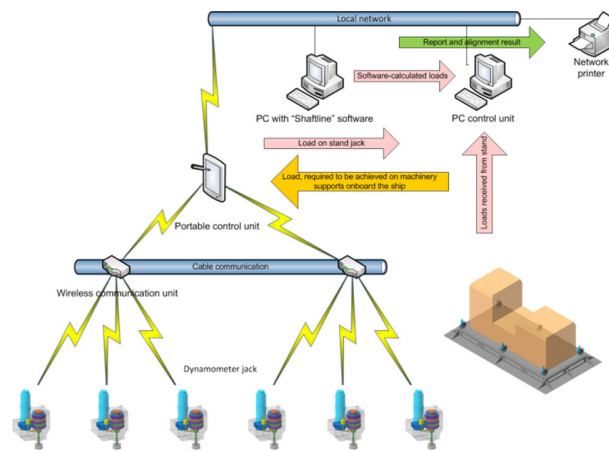

Fig. 4 Functional chart of alignment system

The system operates in three modes: shaftline alignment, large assembly unit mount and stand assembly. Operation in alignment and mount modes is based on application of pre-calculated loads on shaftline bearings (supports) in auto mode. Stand assembly is a reverse process; viz. the system records loads to be applied on supports after large assembly unit has specifications receipt (certain joints clearances).

The system consists of dynamometer jacks, connected to power source and PC control system. Dynamometer jacks and control PC can be connected by cable or wireless connection.

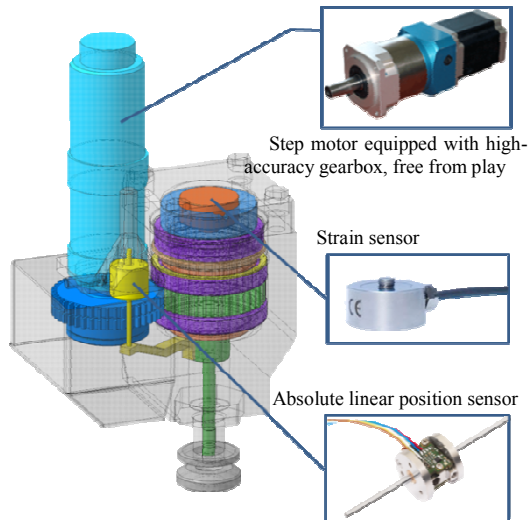

Fig. 5 Configuration of dynamometer jack

Dynamometer jack moves the shaftline under alignment in vertical plane. Also the dynamometer jack is equipped with strain sensor for loads indication and motion sensor, purposed for determination of actual position of shaftline under alignment.

Due to small dimensions of dynamometer jack, it can be installed in standard holes, purposed for fixation of bearing on the ships foundation. These holes are positioned symmetrically to bearing surface axle, and dynamometer jacks are installed in the holes diagonally to measure the bearing load. Averaged load between two diagonally positioned dynamometer jacks is support reaction plus weight of the bearing itself.

Special software is pre-installed in the PC of control system. Upon selection of required operation mode, actual dimensions, specifying alignment diagram (mount, stand assembly), as well as required bearing loads (supports), weights of bearings (when aligning the shaftline) and auxiliary parameters are entered in the program.

Initial data, required for shaftline alignment can be exported in automated alignment system from program complex, purposed for calculation of alignment technological parameters (software "Shaftline").

When mounting large assembly unit, requiring stand loads application, the dynamometer jacks, installed on large assembly unit supports, are connected to power source and control system. Prior to installation of alignment system, the large assembly unit shall be positioned on pullout appliances. After the large assembly unit is based on dynamometer jacks, the control system evaluates current loads on supports and calculates length of dynamometer jacks motion. Upon receiving alignment command from operator, the system lifts the large assembly unit, analyzes load variations, re-calculates motion value (when necessary) and aligns shaftline to design loads.

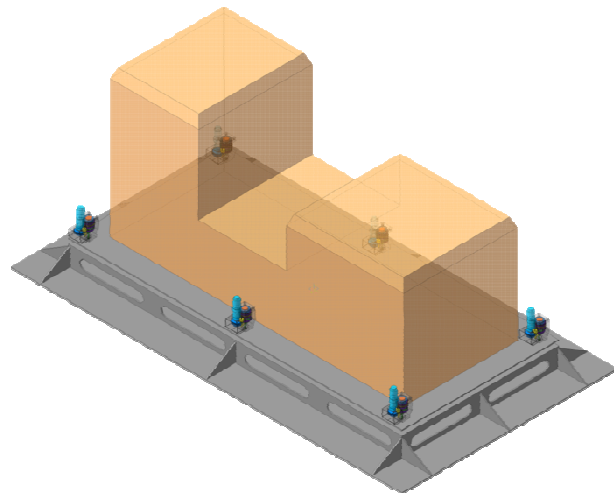

Fig. 6 Large assembly unit mounting chart (stand assembly)

For alignment of shaftline by loads on supports of each bearing to be aligned, two dynamometer jacks are installed diagonally. After that bearings of shaftlines are shifted from pullout appliances to dynamometer jacks and the system evaluates actual loads on shaftline supports. When calculating stressed-deformed state of shaftline, it is provided as cutless statically indeterminate beam, and the algorithm for pre-set loads achievement is calculated basing on induction coefficients values. For that matter and to evaluate actual induction coefficient, each shaftline bearing prior to alignment is lifted for calibration. Basing on lifting results, the system calculates movement value of each bearing and alignment begins.

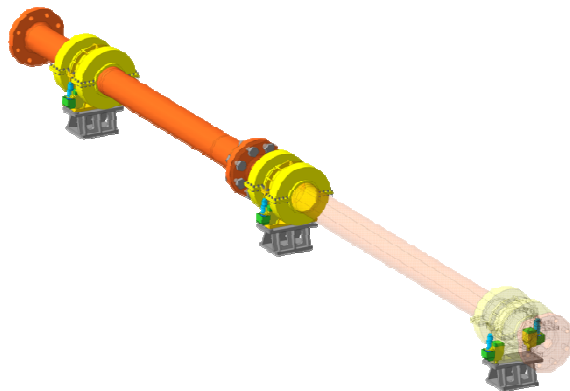

Fig. 7 Shaftline alignment chart

#### Specifications:

- Max. load on each dynamometer jack – 25 kN to 100 kN,
- Shaftline lifting during alignment – not less than 40 mm;
- Accuracy – not less than 2%;
- Rod movement accuracy – 0,05 mm;
- Providing operation of not less than 20 dynamometer-jacks.

REFERENCES

- [1] Guidance notes on propulsion shafting alignment. American Bureau of Shipping. Houston, 2006
- [2] Amit Batra, K. Shankar, S. Swarnamani. Propulsion shaft alignment measurements on warships afloat and alignment solution using multi-objective optimization // Journal of Marine Engineering and Technology. No.A9 2007. IIT Madras, Chennai, India
- [3] Release 11.0 Documentation for ANSYS. ANSYS Inc., 2007.
- [4] Cook, Robert Davis. Finite element modeling for stress analysis / Robert D. Cook. 1994
- [5] V.N. Lubenko, Yu.A. Vyazovoy. Assembly of ship shaftlines. Saint-Petersburg, Russia, 2007.
- [6] V.G. Nesterov. Aspects of alignment of shipshaftlines. // Symposium on mechanics. Saint-Petersburg, Russia, 2000.