

TACS : Thermo Acoustic Cooling System

Z. Zarid, C. Gamba, A. Brusseau, C. Laborie, and K. Briens

Abstract—Cooling with sound is a physical phenomenon allowed by Thermo-Acoustics in which acoustic energy is transformed into a negative heat transfer, in other words: into cooling! Without needing any harmful gas, the transformation is environmentally friendly and can respond to many needs in terms of air conditioning, food refrigeration for domestic use, and cooling medical samples for example. To explore the possibilities of this cooling solution on a small scale, the TACS prototype has been designed, consisting of a low cost thermoacoustic refrigerant “pipe” able to lower the temperature by a few degrees. The obtained results are providing an interesting element for possible future of thermo-acoustic refrigeration.

Keywords—Domestic Scale Cooling System, Thermoacoustic, Environmental Friendly Refrigeration.

I. INTRODUCTION

IMPOSED energy limitation and environmental challenges are today forcing for the research of new sustainable, greener and cleaner solutions in the very important sector of refrigeration. Current systems are in particular criticized for their high-energy consumption and the use of high greenhouse gases.

This article focuses on a new innovative solution based on thermoacoustic refrigeration. The term refers to the phenomenon of interaction between the propagation of acoustic wave and thermal effects, in other words, to the action of creating a sound from a heat source, and on the other side, to the possibility of creating heat from a sound. It is this last point which will be of interest here.

A sound wave is formed by small pressure fluctuations moving in fluid or solid environment and consists in a succession of compression and expansion propagating in the medium. A compressed gas heats whereas a relaxed gas cools down; each compression/expansion of a gas volume is therefore accompanied by a rise/decrease of local temperature. The wave also generates oscillation of small gas volumes around in the medium. These volumes are therefore hot and compressed on one side, and cold and relaxed on the other side. If a solid and conducting object is introduced in the fluid, such as a metal plate, it will play the role of an accumulator or thermal delayer. At each stage of compression, the heated gas gives off heat to the plate, while in relaxation phase it receives heat. Considering all these elementary volumes, a heat transport can be observed from one end of the plate to the other. A temperature difference between the two ends will be created, which constitutes the centerpiece of Thermo-Acoustics [1]. To increase this resulting thermal power, two

important elements have to be enhanced. First, the surface of interaction between the fluid and the solid must be increased. As a result, one will form a network of parallel flat plates called a “Stack”. Secondly, it is also necessary to create a resonant environment in which the sound can be amplified in order to increase acoustic effects. Similarly, it is necessary to surround the stack by a hot source on one side and a cold one on the other side, facilitating the researched heat exchange and the creation of a temperature gradient.

This technology has already been developed in very large industrial cooling systems using a linear motor as an acoustic source [2]. The goal of TACS project is to show that Thermo-Acoustics could as well be applied on a smaller (individual as opposed to industrial) scale in view of developing a working refrigerating prototype for residential or specific purposes.

II. THEORETICAL MODEL

In order to properly carry out the project, a theoretical model has been first established and the following simplifying assumptions have been made, later validated by experimental results.

The fluid is considered as perfect, i.e. as a fluid in which all forces are neglected except pressure. In addition, adopting the acoustic approximation, the calculations have been all carried out to order 1 versus ρ , μ , ν and T . This implies that a stationary sound wave moving in this environment results in a reversible adiabatic (isentropic) transformation of fluid particles in the resonator. In the study, only one-dimensional waves have been considered; hence all the introduced quantities depend only on a space variable (x) and on time.

The theoretical model [3] enables the establishment of power (1) and of system efficiency (2).

$$P = \frac{2ad'P_0}{\pi\gamma} \left(\frac{P_m}{P_0}\right)^2 \sqrt{\frac{\gamma RT_0}{M}} \sin \alpha \left[\cos \alpha - \frac{T_c - T_f}{1} \frac{2L}{\pi T_0(\gamma-1)} \sin \alpha \right] \quad (1)$$

$$\eta = \frac{2L}{\pi(\gamma-1)l} \frac{\sin \alpha}{\cos \alpha} \quad (2)$$

As it can be seen, (1, 2) depend on all system variables which are therefore essential for its sizing. In addition, power and efficiency are key quantities of the system, and must be optimized. If power and efficiency are depending on variables allowing optimize one of these two quantities without penalizing the other (eg pressure), it is clear however according to (1, 2) that compromises have to be made sometimes in order to maximize both power and efficiency.

Z. Zarid is with the Energy and Environment Department, ECE Paris, School of Engineering, Paris, France (phone: +336 13 39 36 98; e-mail: zarid@ece.fr).

III. MATH

A. Material Sizing

In the design process of correct full-scale individual prototype sizing, it is of utmost importance to maximize its power. This is resulting from the theoretical study and corresponding calculations, which are allowing to accurately dimension all system components.

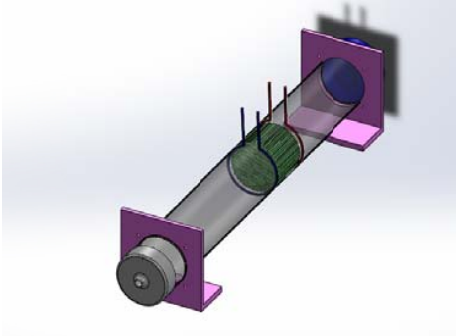

Fig. 1 3D Model of the Prototype

Along this line, a cylindrical tube of $L = 1$ m long and $d' = 12.5$ cm diameter containing a gas (air or helium) has been finally chosen. The value of internal diameter is very important because it is directly related to thermal power and to diameter of acoustic source membrane. A loudspeaker generating sound waves is placed at one end. The location of the stack has been precisely calculated at 34cm from acoustic source, so as to optimize thermal power. It is surrounded by the cold source and the heat source. In this device, the fluid is cooled at the tube output.

As indicated above, the stack is the main part in the system. It amplifies the temperature gradient in the tube by enhancing heat exchange between the fluid and the plates. However it should not interfere with the passage of the standing acoustic wave, while maximizing thermal exchanges between the plates. Its importance involves studying specifically the dimensions of its holes. The stack is modeled as a network of horizontal and vertical parallel plates. It then forms an array of squares that should be 0.9mm large, and spaced by a 0.09mm thin plate. This size must be strictly respected because the network of parallel plates ought to be large enough to let the sound waves travel without interfering with the skin effect induced by the fluid on stack plates, but also close enough to optimize the heat exchange taking place there.

The stack length must also be carefully chosen. Indeed, the system performance is inversely proportional to this length. This value must be less than the wavelength of the lowest harmonic. In the case of a 1m long tube, the best length of the stack is $l = 10$ cm [4].

B. Physical Sizing

The study is based on optimization of real Carnot power, i.e. the power taking into account Carnot efficiency. Efficiency and power equations (1,2) depend on two important

parameters: the fluid pressure and the polytropic coefficient of the fluid.

When plotting the variation of Carnot thermal power versus the polytropic coefficient for different fluids, at a temperature of 20°C when allowed (or else the fluid temperature with a pressure of 1 bar), Fig. 2 is obtained. As a general trend, thermal power increases with the polytropic coefficient of used fluid. However, it also depends on temperature, which is why for high temperatures (for example, using steam), the power also increases. Thermal power is clearly easier to get under standard conditions with a temperature of 20° Celsius, knowing that in this case using helium gas can provide even more power. The choice here will focus on using helium ($\gamma = 1.667$), which is moreover a mono-atomic gas facilitating propagation of acoustic waves. [5]

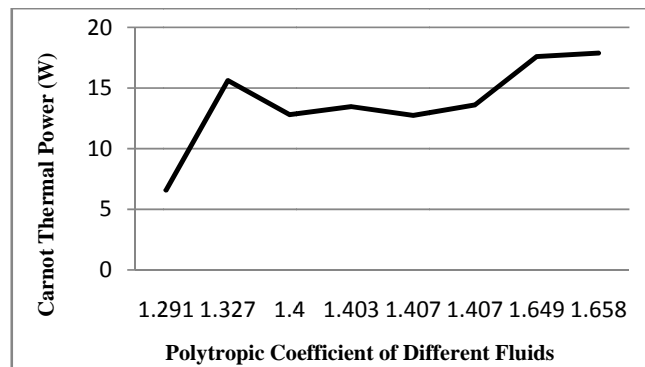

Fig. 2 Thermal power vs polytropic coefficients

When studying Carnot thermal power, its increase can be correlated with pressure increase inside the tube, as shown in Fig. 3. In existing industrial thermo-acoustic systems, the used fluid is often placed under 10 bars pressure, and even up to 30 bars in some cases. Actually, within restrictions of academic environment where the project has been developed, present prototype has been built as airtight as possible, and able to withstand and to operate under such pressures.

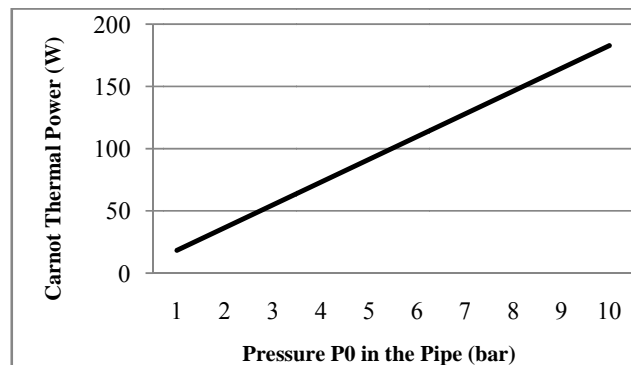

Fig. 3 Thermal power vs pressure

IV. THEORETICAL RESULTS

With system parameters

- $T_0 = 20^\circ\text{C}$, Room temperature
- $T_c - T_f = 20^\circ\text{C}$ Temperature difference between the cold and hot sources
- $P_0 = 1$ bar
- $L = 1$ m, Tube length
- $l = 0,1$ m, Stack length
- $d' = 0,12$ m, Stack diameter

One finds the following theoretical values from (1, 2)

TABLE I
THEORETICAL VALUES FOR HELIUM FROM (1, 2)

Symbol	Quantity	Numerical Value
f	frequency	251.9 Hz
$T_f - T_c$	temperature difference between sources	31°C
P	thermal power	323.97 W
η	system efficiency	5.64
$P \eta$	Carnot thermal power	18.27 W
OO'	stack position	0.34 m
d_2	distance between the plates	$1.1 \cdot 10^{-3}$ m
d_1	plates thickness	$0.11 \cdot 10^{-3}$ m

A. Using Helium

With $M = 4 \cdot 10^{-3} \text{ kg} \cdot \text{mol}^{-1}$, Molar Mass of He, $\gamma = 1,667$, and $R = 8,31 \text{ J} \cdot \text{K}^{-1} \cdot \text{mol}^{-1}$, Perfect gases constant.

TABLE II
THEORETICAL VALUES FOR AIR FROM (1, 2)

Symbol	Quantity	Numerical Value
f	frequency	85.8 Hz
$T_f - T_c$	temperature difference between sources	31°C
P	thermal power	76.45 W
η	system efficiency	9.41
$P \eta$	Carnot thermal power	7.2 W

B. Using Air

With $M = 28,97 \cdot 10^{-3} \text{ kg} \cdot \text{mol}^{-1}$, Molar Mass of Air, and $\gamma = 1,4$.

V. MATERIAL AND METHODS

A. Material Used

Once the theoretical study established, it was necessary to determine in a realistic way, the materials to be used for construction of a viable prototype. The idea was to find materials that best meet theoretical study within pre-determined budget:

- The tube: Made of stainless steel 304, and easy to find in main stores.
- The acoustic source: a CPA 6-75 speaker, both small and powerful in low frequency range, and with excellent reliability, which is a very important characteristic for the prototype.
- The stack: The machining of a stack corresponding to

theoretical dimensions proved impossible within the framework of low cost project in academic environment. The use of a car catalytic converter then proved a good compromise. It is a monolith ceramic composed of cordierite (magnesium silico-aluminate $2 \text{ Al}_2\text{O}_3 - \text{SiO}_2 - 5 \text{ MgO}$), and covered with a thin layer of crystals: alumina, ceria and rare metals from the platinum group. This object has the geometry and the physical properties needed for the stack.

- The fluid: air and helium gas have been used as consistent with theoretical results, and valuable for discussing the importance of fluid type.
- The heat exchangers: The purpose of the heat exchangers is to ensure the heat transport by conduction at stack ends. Temperature difference between heat tanks necessary for the device to work as a refrigerator has to be lower than 31°C according to theoretical results. This temperature being easily reachable, the use of copper pipes (as copper has a high thermal conductivity) in which circulate hot and cold water is enough. [6]

B. Assembly Methods

First issue in assembly work was to machine the stainless steel tube to "prepare" it for the other components. Thus in order, four holes were drilled to enable the heat exchangers to pass. The stack has been inserted at the position determined by theoretical study. The exchangers have then been placed, and the sealing was ensured by joints and chewing. A ring of Plexiglas was glued to one end of the tube to serve as a fixing support for the speaker. Finally, the different thermal and acoustic sensors have been placed so as to follow the experimental results before closing the other end of the tube and adding pipes to supply cold and hot water exchangers.

C. Experimental Reading Methods

After prototype assembly, experiments have been run to measure temperature variation as a function of time. Changing one variable at the time, several experiments have been performed to validate different theoretical points. Experimental variables are the ones imposed at device activation, which are susceptible to alter the results.

- The first experimental variable is the used fluid. The experiment has been initially conducted with air and then in a second step with helium.
- A second important parameter is the frequency delivered by the speaker. For each fluid, the operation has been tested with two frequencies: the theoretical frequency and the optimal measured experimental frequency.
- The sources temperatures are also experimental variables.
- The last varied parameter is the origin of cold source: air or helium at room temperature or cold water flowing through the heat exchanger.

VI. RESULTS AND DISCUSSION

A. Experimental Results

Experiments are showing that it is possible to lower by 1.8°C the temperature of an enclosure containing air (92.8Hz) and by 7°C when using helium (at 236.4 Hz) under the best experimental conditions, with the prototype used, see Table III.

TABLE III
EXPERIMENTAL RESULTS FOR AIR AND HELIUM GAS

Fluid	Frequency	Hot source	Cold source	Time (min)	Temperature difference
Air	Theoretical	Hot water	Air at room T	45	- 1.5°C
	Experimental	Hot water	Air at room T	45	- 1.8°C
	Experimental	Hot water	Cold water	60	- 2.7°C
Helium	Theoretical	Hot water	Cold water	60	- 6.6°C
	Experimental	Hot water	Cold water	60	- 7°C

Different experiments have been carried out showing that it is necessary to have two active sources and for best results, to launch a wave the frequency of which is fine tuned from theoretical value. In fact experimental frequency is determined from theoretical frequency basis, and further adjusted via a frequency generator to obtain a periodic signal as sharp as possible on the oscilloscope. This is expectable since the theoretical study has been developed with fictitious heat sources, not disrupting the passage of sound wave, using a perfect fluid and stack. So here acoustic tube properties are not exactly the same as in theoretical study.

The various experiments also showed that the two sources should emit a continuous heat flow. Indeed, in experiments using fluid at room temperature as a cold source, the obtained temperature difference quickly stagnated. It was concluded that this was probably due to stack overheating: it warms up completely because of hot source after a certain time, which stops the process. The cold source is simply the ambient air, and cannot counteract the effects of heat source on the stack. For this reason it is necessary to use "active" sources with a constant flow to prevent stack overheating and maintain temperature gradient. Here, to get the best possible result, sources are consisting of a unit of hot water and another one with water flowing at room temperature. In this case, no temperature stagnation is noticed, the thermo-acoustic phenomenon is effective until the speaker is turned off.

From these results, the same protocol has been directly applied to all the other experiments. The use of helium highlighted the phenomenon more significantly. It should be noted, first, that temperature limit is reached in about one hour, see Fig. 4 and 6. This threshold is lately obtained mainly because present prototype is not insulated.

Moreover, it is interesting to observe a 'response time' of about 10' for present system during which temperature is almost not decreasing with air in contrast with helium gas, see Fig. 5 and 7. Though again related to lack of good enough thermal insulation, gas nature is an important element in system design. This is an issue to get very inexpensive final system, and because response time is a major feature for a system to be used in residential area, it has to be optimized with respect to these two parameters (gas nature and insulation).

Finally, although the prototype studied here was not pressurized, which would greatly increase its thermal power (more particles imply larger collisions and higher heat exchange), present results are already encouraging and demonstrate the feasibility of such a system.

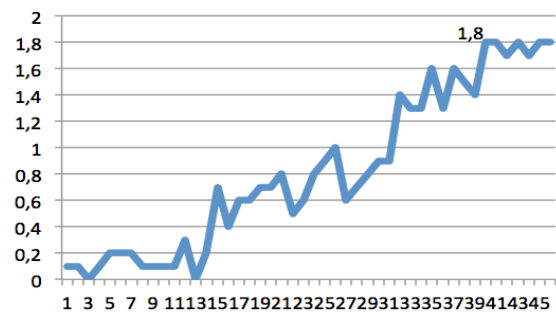

Fig. 4 Temperature difference with air vs time

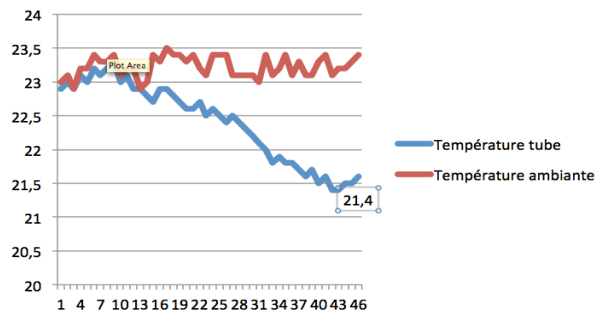

Fig. 5 Tube and outside temperature variations in air vs. time

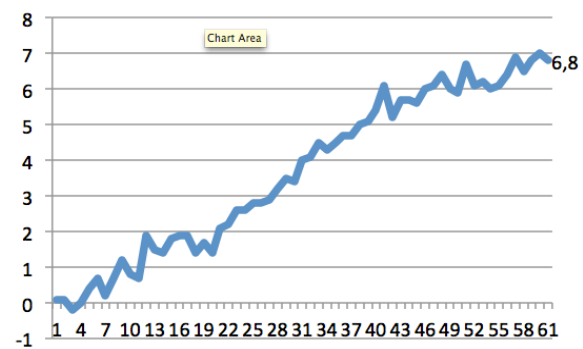

Fig. 6 Temperature difference with helium vs. time

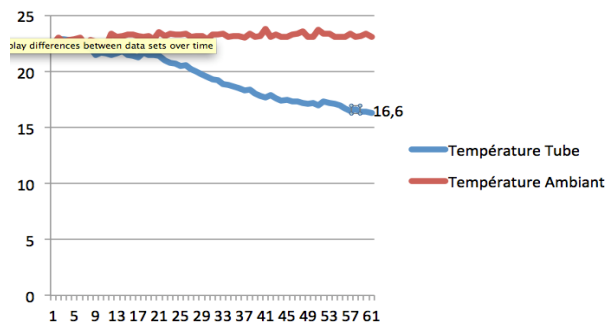

Fig. 7 Tube and outside temperature variations in helium vs. time

B. System Efficiency

From Fig. 4 and 6 representing experimental curves of the temperature difference recorded as a function of time, it is possible to calculate actual system efficiency. One finally gets with Air $\eta_{\text{Exp}}(\text{air}) = 1.8\%$, and with Helium $\eta_{\text{Exp}}(\text{helium}) = .6\%$ to be compared to corresponding theoretical values from Table I and II $\eta_{\text{Th}}(\text{air}) = 9.41\%$, $\eta_{\text{Th}}(\text{helium}) = 5.64\%$. Owing to academic conditions of experimental setup, these relatively low efficiencies are not surprising, insofar as they reflect not only all system leaks, but also actual system performance, very different from perfect theoretical Carnot cycle calculation. Moreover, the higher efficiency with air than with helium confirms that there are leaks in the system, other than heat loss.

VII. CONCLUSION

The main point of TACS study suggests that despite a very low efficiency, due to experimental conditions in very limited budget academic environment and at atmospheric pressure, the system already exhibits interesting cooling capacity. Significant temperature difference has been measured over a period of time, providing a proof of principle for modest size systems.

If it is not possible to act on time variation, it is possible to influence the magnitude of temperature curve. As shown by theoretical study, thermal power varies linearly with pressure, once all other variables are fixed. So the interest of the device is increased when it is pressurized as evident from experimental and theoretical efficiencies.

The results suggest a forthcoming more complete theoretical study to be done in continuity of present project, taking into account physical imperfections of fluids, introduction of more appropriate heat sources and with a more relevant experimental model.

ACKNOWLEDGMENT

The authors are very much indebted to ECE for having provided the environment of the study, to Dr E. Cabet for advice during the research and Pr M. Cotsaftis for help in preparing the manuscript.

REFERENCES

- [1] Garrett, S. L., Backhaus, S., 2000, "The power of sound", Am. Sci. 88 (6), 516-525.
- [2] Garrett, S.L., Adeff, J.A. & Hofler, T.J., 1993, "Thermoacoustic refrigerator for space applications", J. Thermophysics and Heat Transfer 7(4) 595-599.
- [3] Z. Zarid, C. Gamba, A. Brusseau, C. Laborie, K. Briens, 2013, "TACS Final Report", ECE Report, ECE, Paris.
- [4] Hofler, T.J., 1986, "Thermoacoustic refrigerator design and performance", Ph. D. thesis, Physics Department, University of California at San Diego.
- [5] G. Pénélet, "Introduction à la Thermoacoustique", unpublished
- [6] Garrett, S.L., Perkins, D.K. & Gopinath, A., 1994, "Thermoacoustic refrigerator heat exchangers: design, analysis and fabrication", Proc. 10th International Heat Transfer Conference, Brighton, UK, 9-HE-9, August 14-18, 375-380.