

# Designing and Manufacturing High Voltage Pulse Generator with Adjustable Pulse and Monitoring Current and Voltage: Food Processing Application

H. Mirzaee, A. Pourzaki

**Abstract**—Using strength Pulse Electrical Field (PEF) in food industries is a non-thermal process that can deactivate microorganisms and increase penetration in plant and animals tissues without serious impact on food taste and quality. In this paper designing and fabricating of a PEF generator has been presented. Pulse generation methods have been surveyed and the best of them selected. The equipment by controller set can generate square pulse with adjustable parameters such as amplitude 1-5kV, frequency 0.1-10Hz, pulse width 10-100 $\mu$ s, and duty cycle 0-100%. Setting the number of pulses, and presenting the output voltage and current waveforms on the oscilloscope screen are another advantages of this equipment. Finally, some food samples were tested that yielded the satisfactory results. PEF applying had considerable effects on potato, banana and purple cabbage. It caused increase Brix factor from 0.05 to 0.15 in potato solution. It is also so effective in extraction color material from purple cabbage. In the last experiment effects of PEF voltages on color extraction of saffron scum were surveyed (about 6% increasing yield).

**Keywords**—PEF, Capacitor, Switch, IGBT

## I. INTRODUCTION

PULSE-shaped voltage is required in many applications such as PEF food preservation, radar, laser, and accelerators. Pulsed Electrical Field (PEF) technology is based on the phenomena that biological membranes are punctured when an external electrical impulse is applied. This can be helpful, for example, in producing fruit juices, by improving the yields of extractable ingredients so that enzyme treatment can be avoided or reduced and the quality of the juice can be improved[1].

In the PEF process, the effects of the pulse shape on the level of inactivation has been investigated by researchers ([2]-[3]). The investigations indicate that the preferred pulse shape is more or less a square, where a certain minimum threshold voltage should be established during a certain minimum time ([4]-[5]). In particular in high power applications, such as PEF on industrial scale, it is difficult to generate a square shape because of parasitical structural impedances and the level of impedance matching and the availability of the required

switch devices [6].

Electrical pulses can be generated with different wave shapes including exponentially decaying, square waves and oscillating pulses. Moreover, they can be monopolar or bipolar.

Monopolar exponential decaying and monopolar/bipolar square wave pulses are the most common in the application of PEF in food technology. Switch is one of the most important parts in pulse generators[7].

Solid state switches such as SCR (Silicone Controlled Rectifier), GTO (Gate Turn-off) or IGBT (insulated Gate Bipolar Transistor) switches require less complex driving circuits and are easy to handle and control by external triggering and optimum variability of pulse parameters. In a capacitive storage system, when the high voltage switch is closed by a trigger signal or after its breakdown voltage has been achieved, the energy stored is discharged to ground across the discharge circuit with a protective resistor and the treatment chamber with the food material.

Generation of an exponential decay pulse requires a switch with turn on capability only, as the total energy stored in the capacitor bank will be discharged. Square wave pulses can be realized either by an incomplete discharge of a capacitor with high capacity by a switch with on/off capability or a more complex pulse forming network, providing a relatively constant voltage during the pulse width. As switches with turn off capability are hardly available for high power application systems ([8]), serial or parallel connections of switches ([9]) or lumped or distributed pulse forming networks with several sections of capacitors and inductive elements have to be used. Square wave pulses maintain a high voltage level for the total impulse width, whereas exponential pulses have a long tail with low electric field. Studies comparing the efficacy of different pulse waveforms for PEF inactivation have been conducted ([10]), which concluded that both are effective for microbial inactivation, but square wave pulses would save energy and require less cooling effort.

A square pulse can, amongst others, be generated with a hard-switched circuit where a large capacitor is connected to the load during the specified time. The capacitor is large enough to neglect the voltage drop during pulsing. In such a hard-switched circuit the switch should have turn-off capability, which implies that this type of circuit is limited to low and moderate power levels, because switches with turn-off capability, such as IGBT's (Insulated Gate Bipolar Transistor) or MOSFET's, are not available for high power[8].

H. Mirzaee is with the Department of Electrical and Electronic Engineering Khorasan Research Institute for Food Science & Technology, Mashhad, Iran (phone: +98-511-5003333; fax: +98-511-5003332; e-mail: mirzaee@kriifst.ir).

A. Pourzaki is with the Department of Electrical and Electronic Engineering Khorasan Research Institute for Food Science & Technology, Mashhad, Iran (phone: +98-511-5003333; fax: +98-511-5003332; e-mail: pourzaki@kriifst.ir)

However, by series and parallel connection of these switches the power range is continuously increasing in the last decade ([9], [11],[12]).

Treatment chamber: The other major component of a PEF unit is the treatment chamber, used to transfer electrical voltage pulses to food. It basically consists two electrodes.

The proper design of the treatment chamber is important in order to assure the effective cellular permeabilization during the process. Many aspects have to be considered such as geometry, size and construction materials. In order to be able to carry out the treatment, the material used as insulator of the treatment chamber should have dielectric strength exceeding the applied electric field intensity. Stainless steel represents the most suitable choice for the electrodes and has been extensively used ([1], [13], [14], [15], [16]). Anyway, the use of other electrochemical inert material including carbon, gold, platinum and metal oxides has been reported for the electrodes or electrode surfaces ([17]).

Insulator materials used are: Plexiglas ([15]); polysulfone ([1]), PVC ([19]). Several geometries of the electrodes have been proposed. Parallel plate electrodes with a small gap between them provide a uniform electric field and represent the most practical choice of batch chambers ([14]). Disk-shaped and round edged electrodes can minimize the electric field enhancement reducing also the possibility of dielectric breakdown ([1], [18]).

Semiconductor solid-state switches are considered the most convenient option for future applications of the PEF technology. Solid-state switches have a very large operation life span when compared to other type of switches, have better performance, are easier to handle, do not require mechanical components (electrodes or gases), allow higher pulsing frequencies and have low switching and conducting losses; their price also tends to drop, which is common with semiconductor operated equipment.

In high voltages, thyristors can be used series; but for simultaneously turn on each thyristor need high and quick current pulse gate. The pulse transformers that are able to do isolation up to several kilovolts, their inductance leakage is low and cause gate pulse of quick high current and so they are great and expensive.

Isolated gate bipolar transistors (IGBTs) can be used to construct high voltage and power switch. Generally IGBTs with respect to thyristors, have shorter turning on time, faster rise time, and simpler turning off. But the on dissipation of IGBTs is more than thyristors.

Turning on and off time of MOSFETs and IGBTs have about one hundred nanosecond (ns) and about hundreds of nanosecond to a microsecond ( $\mu$ s); respectively. Therefore switching frequency of MOSFETs is higher than IGBTs. Voltage drop on MOSFETs drain and source is changed from 3 to 10V but on IGBTs is usually below 2V. So the dissipation of the lightness situation of MOSFET circuits is more than IGBT. Table 1 shows briefly characteristics of three type of described semiconductor switch.

TABLE I  
THE CHARACTERISTICS OF MOSFET, THYRISTOR AND IGBT SWITCH

Characteristics/switch	Mosfet	IGBT	Thyristor
Turning off capability	Has	Has	Doesn't Have
Speed	Faster	Medium	Slower
Cost	More Expensive	Medium	Cheaper
Static dissipation	Higher	Medium	Lower

## II. SYSTEM DESIGNING

In the system design process, general specification of electrical equipment, electronic hardware (digital and analog) and software, and relation of these components with each other will be determined.

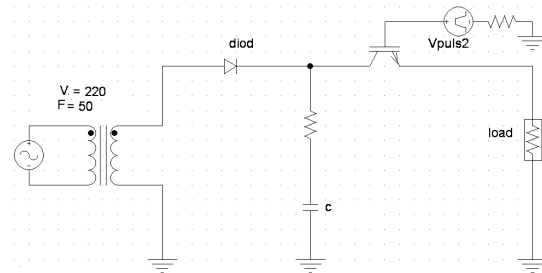

Fig. 1 The general form of the PEF equipment

### A. Electrical section specifications

All tables and figures you insert in your document are only to help you gauge the size of your paper, for the convenience of the referees, and to make it easy for you to distribute preprints.

General system of high voltage pulse generation is observed in figure 1. The voltage increases by a transformer from line 220V to high voltage 1000 to 5000V. It is rectified and stored in DC form in a capacitor by the diode. Capacitor voltage is transformed to narrow pulses by triggering signal (Vpulse) and using the switch. Now, each one of these components will be characterized.

Transformer: Necessary output voltage is 1- 5 kV, therefore we need a transformer so that it can change line power 220V to output selective voltage between 1-5 kV. Switching power supply has been used so that changing its frequency tends to various voltages in the output.

Capacitor: The minimum desired load resistance is 150 $\Omega$ . Necessary maximum pulse width is 100 $\mu$ s; i.e. in the worst situation, in interval of 100 $\mu$ s, the current of 33A must be loaded. Assumed capacitor will be discharged after each pulsing. So we can calculate energy of each pulse as following:  $W=Pt=VI t \approx 5000 \cdot 33 \cdot 100 \cdot 10^{-6} = 16.5$  w

This energy is provided by capacitor that is:  $W=0.5 CV^2$

Then:  $C=2W/V^2=2 \cdot 16.5/5000^2=1.32 \mu$ F

For certainty, a 2 $\mu$ F capacitor bank is used. Capacitor bank is constructed using series and parallel capacitors with following specification:

- Individual capacity: 1 $\mu$ f
- Maximum tolerable voltage: 1300V
- Maximum instantaneous current: 1000A
- Maximum voltage of total capacitor: 5200 V

- Capacitors number: 32

So each four capacitors are series together and package. All eight packages are fastened parallel. Finally the capacitor bank insulated and constructed with dimension 13\*13\*15cm.

Diode: The diode rectifies ac output of transformer in the form of semi-wave and charges the capacitor. It should tolerate the current that charges the capacitor. Tolerable voltage of the diode in the cutoff situation is as following:

$$VD(max) \cong 5 \text{ kV}, \quad IC(ave) = P_{ave}(in) / VD(max) = 165 / 5000 = 33 \text{ mA}$$

Practically seven number of one ampere and one kilovolt diodes by name BYT52M are series and insulated with resin.

Switch: The repetition rate is between 1 and 10 Hz and has to be programmable. Therefore a controllable switch should be existed in path of the load so that with control of the switch by a controllable and programmable circuit, the pulse frequency was controlled between 0.1 and 10 Hz. Other parameters were:  $V = 5 \text{ kV}$ ,  $I = 33 \text{ A}$ ,  $t_{on} < 1 \mu\text{s}$ , and  $t_{off} < 1 \mu\text{s}$ .

The switch has been formed from seven series stages. Each stage is a switch module with a 1200V IGBT. Each module separately is fed with isolated driver.

The modules have pulse driver because IGBT can't continually remain on. The modules specifications are as following:

- Voltage of each module : 1200V
- Maximum pulse current of each module : 180 A
- Rise time: less than 30 ns (at  $IC = 24 \text{ A}$ )
- Fall time: less than 200 A/ $\mu\text{s}$  (recovery time)
- Transistor voltage in saturation state (on state) : 3.2 V (at  $IC = 45 \text{ A}$ )

*B. Electrical equipment*

Internal circuit of this machine is observed in figure 2. This system in addition to the pulse generation can measure the environment temperature. We can indirectly obtain material under test resistance by the current voltage waveform amplitude. In figure 3, this machine is showed in various angles. The machine has been formed from different sections so that we can divide them to three parts including input, output, and other parts.

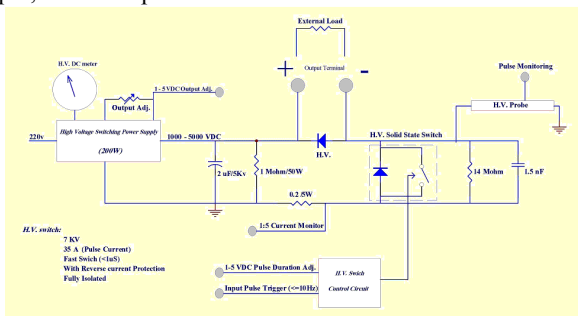

Fig. 2 practical circuit of the PEF



Fig. 3 Electrical and Controller unit of PEF set

*Inputs*

Power: input power is 220 V. The equipment maximum power and current consumption are 200W and 0.9A, respectively. This input is equipped with two number of one ampere fuses.

Pulse voltage setting input: Using the input dc voltage between 1 to 5V, output voltage of the equipment can be set from 1 to 5 kV. HV automatic key on the panel deactivates this input so the voltage volume controls the output voltage.

Pulse width setting input: applying the input dc voltage between 0 to 5V tend to varying pulse width between 1 to 100  $\mu\text{s}$ .

Pulse automatic switch: this switch inactive pulse width input so pulse can be generated by push bottom key with 13 $\mu\text{s}$  pulse width.

Trigger input: in each rising edge of this input signal, a pulse is generated. Pulse automatic switch can inactive this input and active push bottom key.

*Outputs*

Voltage indicator: For obtaining real numbers, read digits should be multiply in coefficient 500.

High voltage pulse output: Main goal of the equipment is this signal. The experiment chamber will be connected to this output.

Voltage waveform output: In this output, main output voltage has been attenuated to immune level.

Attenuation coefficient: 200; namely voltage from 1 to 5 kV is decreased to 5 to 25V.

Current wave form output: with insertion a resistor in the output current path, the voltage of its two terminals shows current waveform. Used resistance is 0.2 $\Omega$ ; consequently measured voltage values on the oscilloscope screen must be multiplied in number 5 so it will be equivalent to load current. For example, the maximum output current of 20A has view of 4V on the oscilloscope screen.

*Other parts*

Earth wire connection: for assurance from electrical protection of the machine (on the back), this port wire should be connected to electrical earth of the building.

Controller section ground: Oscilloscope or external controller ground should be connected to this pin.

### C. Experiment chamber

The chamber has been constructed in dimensions of 10\*10 cm with depth of 1.5cm (figure 4-a). Metallic plates are made with stainless-steel-316. The insulator all around is from Plexy Glass. Figure 4-b shows the practical constructed chamber.

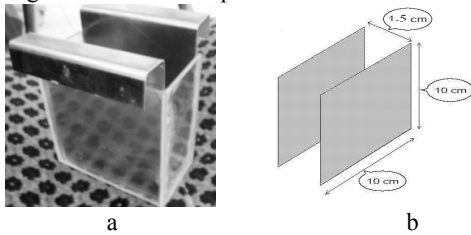

Fig. 4 a) Dimension of fabricated plates b) final chamber

## III. CONTROLLER DEVICE DESIGN

### A. Software

In the control unit panel there are several keys for entering data and commands. MENU key is used to set the machine parameters which appear a new environment. Parameters are selected by UP and Down key, and then the controller will be ready to receive new data. Pressing ENTER key tend to confirm inserted number. Entered setting parameters are saved in the E2PROM memory of the controller. MENU environment is as following:

1. Voltage: 0-5 kV >>.-.<<
2. Frequency: 1-10 Hz >>.-.<<
3. Duration: 10-100  $\mu$ s >>----<<
4. Number/DutyCycle:
  - Number: 0-3000 P >>----<<
  - Duty Cycle: 0-100 % >>----<<

### B. Hardware

Controller hardware unit of the PEF machine has been designed and constructed by using an AVR microcontroller; type ATMEGA32. Necessary information is received by keyboard 4\*4. One 4\*20 characteristic indicator screen shows system work situation and necessary information. Three output signals control the PEF machine which is produced by this controller: two DC signal (0-5V) and a trigger pulse. These DC signals are used to define voltage and pulse width of the machine. The DC signals are generated using PWM technique with micro so that an op-amp circuit converts pulses duty cycle to DC equivalent. Trigger pulse determines the frequency and instant of pulse generating. The schematic of controller hardware has been shown in fig.2.

## IV. RESULTS

The primary load was a pure power 250 $\Omega$  resistor. Pulse characteristic was 2kV amplitude, 10 $\mu$ s width and 10Hz repetition that its oscilloscope screen show is presented in figure 5.

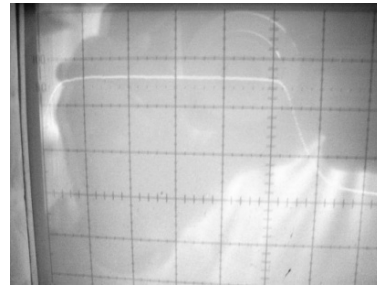

Fig. 5 The pulse on the screen. Time/div=10 $\mu$ s and Volt/div=500V (After applying equipment attenuation factor of 500)

The first experiment is done on purple cabbage, and banana. The chamber plate distance was 2cm. The applied voltage and pulse number were 5kV (i.e. electric field intensity of 2.5kV/cm) and 1000 pulses, respectively which had 10Hz frequency and 100% duty cycle. As it can be seen in fig. 13, the material color changed considerably. These images have been captured 24 hours after the experiment. Note that applying high voltage pulses to purple cabbage tend to extract its color material, while its color without pulse is little.



Fig. 6 the effect of 1000 pulse on the material (5kV, 100 $\mu$ s, purple cabbage and banana after 24 hour) Left sample without PEF and right sample with pulse exertion

In another experiment various voltage (2 and 5 KV) was applied to potato material. Chamber distance was 1 cm and pulse duration 100 $\mu$ s. the photograph was taken after 5hours. Color changes are seen at fig. 6.

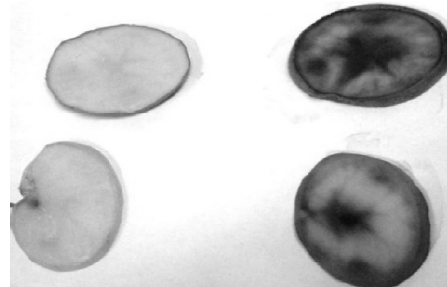

Fig. 7 the effect of 20 pulse 100 $\mu$ s on the potato (top: 5kV, down: 2kV) after 5 hour. Left sample without PEF and right sample with pulse exertion

Reflection and Brix factor of potato in water (before and after PEF) is presented in table 2. Three sample was examined in 5kV/cm field intensity, 100 $\mu$ s pulse duration and 20 pulse number.

TABLE II  
REFLECTION AND BRIX FACTOR OF POTATO IN WATER (BEFORE AND AFTER PEF)

	Before PEF	After PEF
Brix factor	0.05	0.15
Reflection factor	1.33307	1.33317

In another experiment that differs from others, washed scums were tested. After 8min mixing saffron washed out and treated. Figure 8 shows the graph of the saffron effective materials for intact tissue and after PEF applying at pulse width of 100 $\mu$ s, electric field strength of 5kV, and pulse number of 40. AS seen, PEF caused to about 6% increasing in color extraction of saffron.

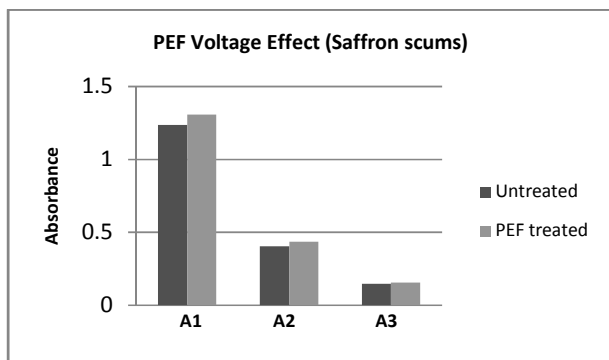

Fig. 8 The graph of the saffron effective materials for intact tissue before and after PEF applying (at 100 $\mu$ s 5kV, n=40). A1: color; A2: taste; A3: aroma

## V. CONCLUSION

A pulse-shaped voltage is required in many applications such as PEF food preservation, radar, laser and accelerators.

In this paper designing and fabricating of a PEF generator has been presented. In this work pulse generation method was based on switching transformer and serial IGBT switches.

Semiconductor solid-state switches are considered the most convenient option for future applications of the PEF technology. Solid-state switches have a very large operation life span when compared to other type of switches, they have better performance, are easier to handle, do not require mechanical components (electrodes or gases), allow higher pulsing frequencies and have low switching and conducting losses

The equipment with controller set can generate square pulse with adjustable parameters. Food container dimensions were 10 $\times$ 10cm with distance of 1-5cm. Their cover was made from fiberglass insulation and metal plates from stainless-steel-316. In the system design process, general specification of electrical equipment, electronic hardware (digital and analog) and software, and relation of these components was determined.

Necessary output voltage is 1- 5 kV; therefore we need a transformer so that it can change line power 220V to output selective voltage between 1-5 kV. Switching power supply has been used so that changing its frequency tends to various voltages in the output. This voltage has adjustment capability from 1 to 5 kilo volt. The minimum desired load resistance is 150 $\Omega$ . Necessary maximum pulse width is 100 $\mu$ s; i.e. in the worst situation, in interval of 100 $\mu$ s, the current of 33A must be loaded. The diode rectifies ac output of transformer in the form of semi-wave and charges the capacitor. It should tolerate the current that charges the capacitor. Practically seven number of one ampere and one kilovolt diodes by name BYT52M are series and insulated with resin. The repetition rate is between 1 and 10 Hz and has to be programmable. Therefore a controllable switch should be existed in path of the load so that with control of the switch by a controllable and programmable circuit, the pulse frequency was controlled between 0.1 and 10 Hz. The switch has been formed from seven series stages. Each stage is a switch module with a 1200V IGBT. Each module separately is fed with isolated driver.

Controller hardware unit of the PEF machine has been designed and constructed using an AVR microcontroller type ATMEGA32. Necessary information is received by keyboard 4\*4. One 4\*20 characteristic indicator screen shows system work situation and necessary information. Three output signals control the PEF machine which is produced by this controller: two DC signal (0-5V) and a trigger pulse. These DC signals are used to define voltage and pulse width of the machine. The DC signals are generated using PWM technique with micro so that an op-amp circuit converts pulses duty cycle to DC equivalent. Trigger pulse determines the frequency and instant of pulse generating.

PEF applying has considerable effects on potato, banana and purple cabbage. It caused increase Brix factor from 0.05 to 0.15 in potato solution. It is also so effective in extraction color material from purple cabbage. In the last experiment effects of PEF voltages on extraction of saffron scum were surveyed that yielded about 6% increasing.

## REFERENCE

- [1] M. Guderjan, P. Elez-Martinez, D. Knorr, "Application of Pulsed Electric Fields at Oil Yields and Content of Functional Food Ingredients at the Production of Rapeseed Oil", *Innovative food science and emerging technologies*, No. 8, Apr. 2007, pp. 55-62.
- [2] Q. Zhang, G.V. Barbosa, B.G. & Swanson, "Engineering aspects of pulsed electric field pasteurisation", *Journal of Food Engineering*, No. 25, 1995, pp.261-281.
- [3] V. Heinz, A. Angerbach, D. Knorr, "Membrane permeabilization in biological materials in response to pulsed electric fields— A highly efficient process for biotechnology", *International Conference on Pulsed Power Applications*, Gelsenkirchen, March 2001, B.03.1-B.03.7.
- [4] Q. Qiu, S. Sharma, M. Jia, & Q.H. Zhang, "An integrated PEF Pilot plant for continuous non-thermal pasteurisation of fresh orange juice" *Transactions on American Society of Agricultural Engineers*, 41(4), 1998, pp.1069-1074.
- [5] T. Grahl, & H. Markl, "Killing micro-organisms by pulsed electric fields" *Applied Microbiology Biotechnology*, 45, 1996, pp. 148-157.
- [6] S.W.H. De Haan, B. Roodenburg, J. Morren, H. Prins, "Technology for preservation of food with Pulsed Electric fields (PEF)", *Proceedings of*

- the Africon 2002 Conference on Electrical Engineering, George (SA), October 2002.
- [7] A. Pourzaki, H. Mirzaee, "Pulsed Electric Field Generators in food processing", 18th National Congress on Food Technology, 15-16 Oct. 2008, Mashhad-Iran.
- [8] N. Mohan, T. N. Undeland, and W. P. Robbins, "Power Electronics; Converters and Design" New York, 1995, Wiley.
- [9] M. P. J. Gaudreau, T. Hawkey, J. Petry, and M. A. Kempkes, "A solid state pulsed power system for food processing" 24th Pulses Power Plasma Science Conference, 2001, Las Vegas, USA.
- [10] Kotnik, T., Pucihar, G., Rebersek, M., Miklavcic, D. and Mir, L. M. "Role of pulse shape in cell membrane electroporation" *Biochimica Biophysica Acta*, 1614, 2003, 193-200.
- [11] V. Chitta, S. Hong, & D.A. Torrey, "Series connection of IGBT's with active voltage balancing" *IEEE Transactions on Industry Applications*, 35, 1999, 917-923.
- [12] A. Pourzaki, H. Mirzaee, "New High Voltage Pulse Generators", *Recent Patents on Electric Engineering*, Bentham Science Publishers Ltd, Vol. 2, No. 1, Jan 2009, 65-76.
- [13] A. Angersbach, V. Heinz, and D. Knorr, "Effect of pulsed electric fields on cell membranes in real food systems" *Innovative Food Science and Emerging Technologies*, 1, 2000, 135-149.
- [14] M. Fincan, F. De Vito, and P. Dejmek, "Pulsed electric field treatment for solid-liquid extraction of red beetroot pigment" *Journal of Food Engineering* 64, 2004, 381-388.
- [15] M.N. Eshghi, and D. Knorr, "High electric field pulse pretreatment: potential for sugar beet" *Journal of Food Engineering* 53 (2), 2002, 265-272.
- [16] N. Menses, H. Jaeger, J. Moritz, D. Knorr, "Impact of Insulator Shape, Flow Rate and Electrical Parameters on Inactivation of E.coli Using a Continuous Co-linear System", *Innovative food science and emerging technologies*, No. 12, Jun. 2011, pp. 6-12.
- [17] A. H. Bushnell, J. E. Dunn, R.W. Clark, and J. S. Pearlman, "High pulsed voltage systems for extending the shelf life of pumpable food production", 1993, U.S. Patent 5,235,905.
- [18] K. Huang, J. Wang, "Designs of Pulsed Electric Fields Treatment Chambers for Liquid Food Pasteurization Process: A Review", *Journal of Food Engineering*, June 2009, pp. 227-239.
- [19] A. Angersbach, V. Heinz, and D. Knorr, "Evaluation of process induced dimensional changes in the membrane structure of biological cells using impedance measurement" *Biotechnol Prog.* 18, 2002, 597-603.