

WDM and OCDMA Systems under MAI Effects: A Comparison Analysis

Hilal A. Fadhil, Thanaa Hussein Abd, Hamza M. R. Al-Khafaji, S. A. Aljunid

Abstract—This paper presents a comparison between Spectrum-Sliced Wavelength Division Multiplexing (SS-WDM) and Spectrum Amplitude Coding Optical Code Division Multiple Access (SAC Optical CDMA) systems for different light sources. The performance of the system is shown in the simulated results of the bit error rate (BER) and the eye diagram of both systems. The comparison results indicate that the Multiple Access Interference (MAI) effects have a significant impact on SS-WDM over SAC Optical CDMA systems. Finally, in terms of spectral efficiency at constant BER of 10^{-12} , SS-WDM offers higher spectral efficiency than optical CDMA since no bandwidth expansion is needed.

Keywords—WDM, OCDMA, BER, RD code

I. INTRODUCTION

MULTIPLE access techniques represent one of the most essential functions of access networks. The three basic multiple access techniques are Frequency Division Multiple Access (FDMA), Time Division Multiple Access (TDMA) and Code Division Multiple Access (CDMA)[1,2]. Optical CDMA systems based on coded sequences of incoherent pulse or coherent pulse, they both enable a limitation of unipolar codes to be avoided and do not entail the high complexity of coherent systems [3]. Optical CDMA is most suitable to be applied to high speed Local Area Network (LAN) to achieve contention-free, zero delay access, where traffic tends to be bursty rather than continuous. Compared with TDMA, CDMA is attractive in other points [4]. High capacity wavelength division multiplexed (WDM) systems have been considered as an attractive solution for long distance transmission and access applications to provide sustained bit rates beyond 10Gbps.

Traditional WDM systems have multiple transmitter lasers operating at different wavelengths, which need to be wavelength selected for each channel and operated at a specific wavelength, producing a costly and complicated approach to WDM [5,3]. This presents a key challenge for their future deployment in the highly cost-sensitive optical network units (ONUs) located in individual homes resulting in the development of spectrum-sliced WDM (SS-WDM) as a lower-cost alternative. The advantages of Optical CDMA are based on discrimination in the time domain to reduce the effects of pulse overlaps.

H. A. Fadhil is senior lecturer with the University Malaysia Perlis, computer and communication school, Perlis, Malaysia (phone: +6049852639; fax: +6049851695; e-mail: hilaladnan@unimap.edu.my).

T. H. Abd and H. M. R. Al-Khafaji are the Ph.D students at computer and communication school, University Malaysia Perlis, Perlis, Malaysia (e-mail: eng_thanaa@yahoo.com, eng.hamza.alkhafaji@gmail.com), their research interest on OCDMA and optical networks.

S. A. Aljunid, is the Dean of Research and Development unit at University Malaysia Perlis, perlis-Malaysia (e-mail: syedalwee@unimap.edu.my).

Random and simultaneous access protocol. No need for the strict timing synchronization and no need for the strict wavelength control. The spectral-amplitude-coding (SAC) schemes have received more and more attention among various optical CDMA techniques (Fig.1). Due to the excellent ability for multiple access interference (MAI) elimination and complementary coding, the concept of SAC was applied in the time-spreading/wavelength hopping optical.

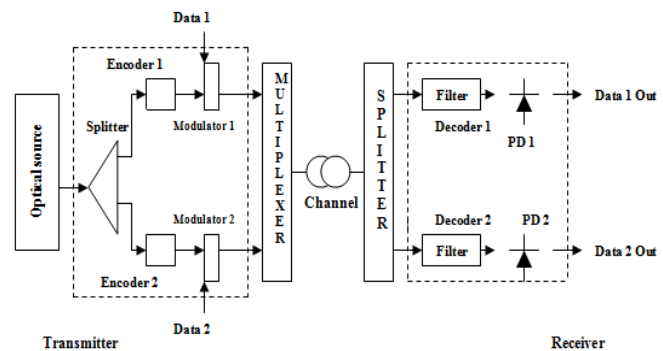

Fig. 1 OCDMA system architecture using spectral direct detection technique

CDMA for cardinality expansion and performance improvement [9,10]. Besides that, Wavelength Division Multiplexing (WDM) is a multiplexing technique that allows several different signals to be carried along a single fiber at the same time. This technique enables bidirectional communications over one strand of fiber, as well as multiplication of capacity.

The main objectives of this project are to: (i) Develop a transmitter-receiver structure for SS-WDM system based on a spectrum sliced; (ii) Develop a transmitter-receiver structure for spectral-amplitude coding OCDMA networks; (iii) compare the performance of SS-WDM and OCDMA systems, in terms of the number of users, multi-access interference (MAI), bit error rate (BER), and spectral efficiency.

II. OPTICAL CDMA / WDM SYSTEM DESIGN

The setup of the proposed RD system using the spectral direct technique is shown in Figure 1. The mathematical analysis of the RD code is discussed and explained in [13]. In the performance analysis, incoherent intensity noise, as well as shot and thermal noises in photodetectors have been considered. A few researchers demonstrated the use of Light Emitting Diodes (LEDs) in a broadband multi-channel WDM transmission [2]. Their idea was to achieve spectral sliced transmission over 4-to-16 WDM channel at bit rates up to 155Mbps per channel. A generalized power budget analysis of spectrally sliced transmission is presented and simulated with their simulation results. The design setup is depicted in Figure 2. The LED light source with center wavelength of 1550nm launched -10dBm average power, and hence it was sliced

spectrally by eight channels using multiplexer and demultiplexer, then multiplexed by a 4×1 coupler into a single mode fiber.

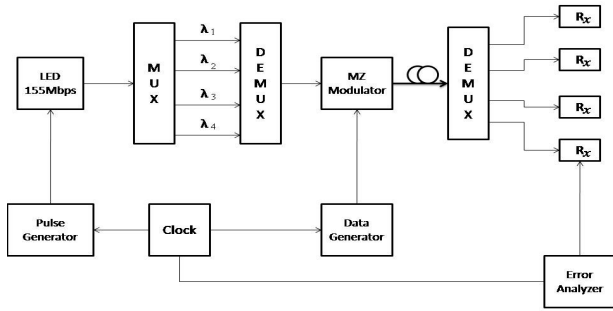
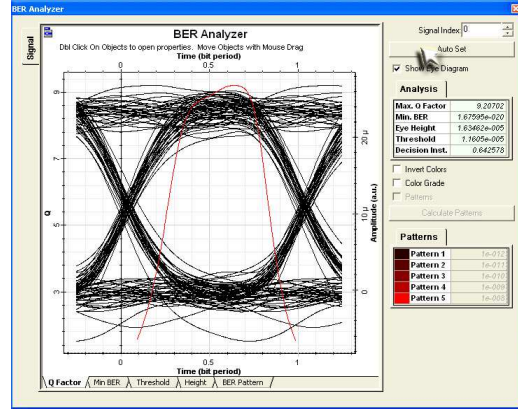

Fig. 2 The proposed WDM system

III. SIMULATION RESULTS

Optical CDMA and WDM systems have been explained and investigated in [6][13]. This section shows all the simulation results for SS-WDM and Optical CDMA systems by using a commercial optical system simulator Optisystem ver. 7.0 from optiwave[12]. The Spectral Sliced-WDM is based on a LED as light source and Optical CDMA based on Random Diagonal (RD) code [13] is being simulated. All the results that are obtained would be analyzed and discussed. Besides that, this section also shows the comparison between both systems SS-WDM and Optical CDMA. The analysis is represented in terms of bit error rate (BER), fiber length, data rate and received power. The physical layer design must take into account the effect of a number of system impairment, such as MAI versus a number of active users. Usually, each impairment results in a power penalty to the system. In the presence of impairment, a higher signal power will be required at the receiver in order to maintain a desired bit error rate. One way to define the power penalty is as the increase in the signal power required (in dB) to maintain the same bit error rate in the presence of impairments. Figure 3 and 4, and 5 show the received signal from a photodetector for two users and four users respectively. It's clearly shown from the detected signal in Figure 3 and Figure 4 that the effects of MAI increased as the number of users increased from two to four users. On the other hand, as shown in Figure 3 and 4, the smaller the number of simultaneous users, the better the eye diagram, which means a low MAI, and a clear detected signal.



(a)

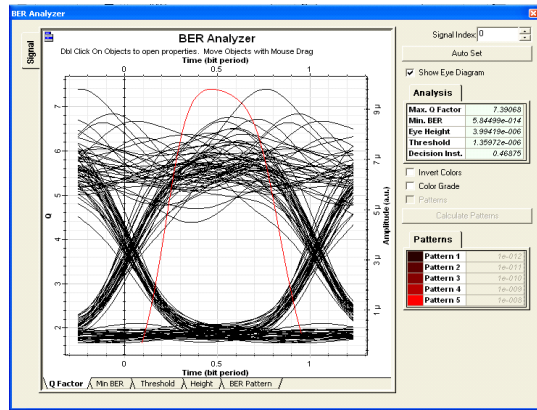

(b)

Fig. 3 The eye diagram for 4 users for (a) SS-WDM with a BER of 1.5×10^{-20} (b) SAC-Optical CDMA with a BER of 5.4×10^{-14}

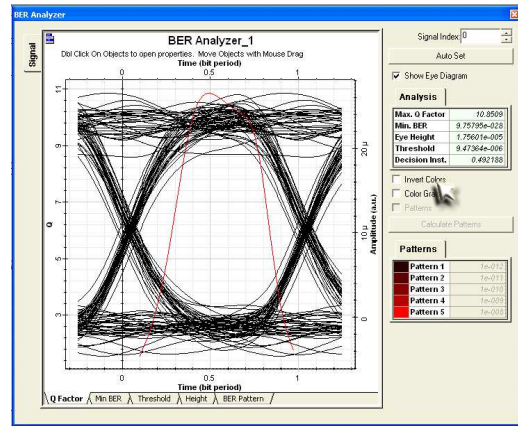

(a)

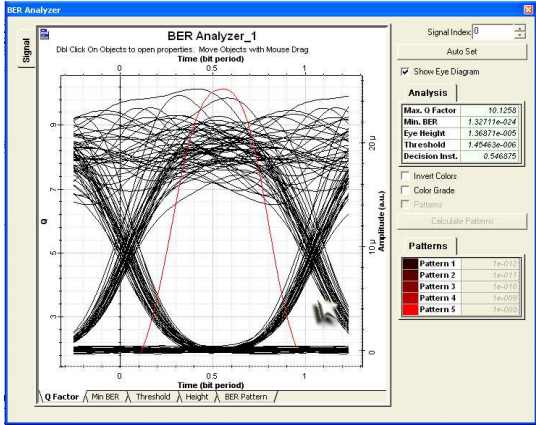

(b)

Fig. 4 The eye diagram for 2 users (a) SS-WDM with a BER of 9.7×10^{-28} (b) SAC-Optical CDMA with a BER of 1.32×10^{-24}

The power penalty due to SS-WDM and Optical CDMA systems is reported in Table I for K=2 and K=4 respectively. The results in this table reveal that the Optical CDMA system has less power penalty compared with SS-WDM system.

TABLE I
RECEIVED POWER OF SS-WDM AND OPTICAL CDMA SYSTEMS

Number of users, K	SS-WDM (BER and Received Power)	SAC Optical CDMA (BER and Received Power)
2 users	BER= $1.33e^{-24}$ Psr ₁ =-17.32dBm	BER= $9.26e^{-28}$ Psr ₁ =-12.52dBm
4 users	BER= $5.84e^{-14}$ Psr ₂ =-15.02dBm	BER= $1.68e^{-20}$ Psr ₂ =-11.02dBm
Power penalty, dB	Psr ₁ - Psr ₂ = 2.32dBm → 18.5dB	Psr ₁ - Psr ₂ = 1.5dBm → 17.6dB

Figure 5 shows that the performance of SS-WDM and Optical CDMA systems, both systems is compared based on same configuration parameters. However, both systems are simulated under various data rates because the transmitted light source is different (LED for SS-WDM and laser light source for Optical CDMA). However, system performance based on Optical CDMA offers better performance than SS-WDM system (LED suffers from high beat noise degradation compared with laser light source). For SS-WDM the data rates are 155Mbps and for Optical CDMA is 2.5Gbps. Both systems having the same channel spacing of 0.8nm and must be selected carefully to obtain minimum crosstalk. Finally, a fundamental measure of the performance of both systems is the spectral efficiency (ζ), b/s/HZ that specifies the overall throughput per unit of Optical Bandwidth associated with a fixed BER. The spectral efficiency could be expressed as [11]

BER vs. Fiber Length

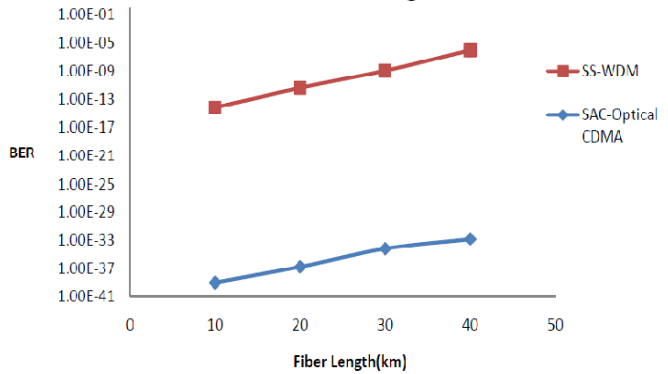

Fig. 5 BER versus Fiber length for both systems

$$\zeta = K R / B_o \quad (1)$$

Where K is the number of an active user emitting at a bit rate R and where B_o is the optical bandwidth occupied by both systems. As shown in table 4.1, the incoherent Optical CDMA system is additionally depended on the users number, which can be much larger number of users is the bandwidth expansion. For example, when the number of user is four, and the chip width of 0.8nm is used, the Optical CDMA will require a spectrum width of $(0.8nm \times 6 = 4.8nm)$, whereas the SS-WDM only require $(0.8 \times 4 = 3.2nm)$. For the SS-WDM, the number of simultaneous users is fixed by the available bandwidth. From this point of view, the SS-WDM display greater spectral efficiency since no bandwidth expansion is needed.

IV. CONCLUSION

This paper studies the comparison between Spectral-Sliced WDM and Spectral Amplitude Coding Optical CDMA based on Random Diagonal code (RD). On an overall, the design specification is successfully achieved in terms of bit error rate (BER), received power, fiber length and data rate for both systems (SS-WDM and Optical CDMA). The standard simulation parameters are based on ITU G652. The results suggest that beat noise represented as Multiple Access Interference (MAI) has negative effects on the performance for both systems. Simulated results for both two users give a BER value of 9.26×10^{-28} and 1.33×10^{-24} for Optical CDMA, and SS-WDM system respectively, while for four users the BER value is 5.8×10^{-20} and 1.68×10^{-14} for Optical CDMA and SS-WDM systems. However, the drawback of the large number of user's is the bandwidth expansion and the introduction of MAI. Finally, Spectral sliced WDM systems using LEDs suffer from beat noise generated by the square law photodetection. It arises because the spectral slices are wider than laser bandwidth the level of beating depends on the ratio of the optical bandwidth to the bit rate. Therefore, the SS-WDM offers greater spectral efficiency compared with Optical CDMA, since no bandwidth expansion is needed.

REFERENCES

- [1] Hongxi Yin, David J. Richardson, "Optical Code Division Multiple Access Communication Networks: Theory and Applications", January 1, 2009.
- [2] J. Kani, K. Iwatsuki and T. Imai, "Optical Multiplexing Technologies for Access-Area Applications", IEEE J. Sel. Topics in Quantum Electron., vol. 12, no. 4, pp.661-668, 2006.
- [3] J. W. Goodman, Statistical optics, New York: Wiley, USA, 2000.
- [4] M.H Reeve, A.R Hunwicks, W.Zhao, S.G.Methley, L.Bickers, S.Hornung: LED spectral slicing for single-mode local loop applications, Electron. Lett., vol 24, pp.389-390, Mar.1998.
- [5] M.H Reeve, A.R. Hunwicks, W.Zhao, S.G.Methley, L.Bickers, S.Hornung : LED spectral slicing for single-mode local loop applications, Electron. Lett., vol.24, pp.389-390, Mar 1988.
- [6] Sil-Gu Mun, Ho-Sung Cho, and Chang-Hee Lee, A Cost-Effective WDM-PON Using a Multiple Section Fabry-Pérot Laser Diode, *Fellow, IEEE, IEEE PTL*, Vol. 23, No. 1, JANUARY 1, 2011.
- [7] Mathew N.O. Sadiku, Optical and Wireless Communications: Next Generation Networks, IEEE Communications Magazine, Summer 2001, vol.39, No.9.
- [8] J.Salehi, H.Chung, and V.K.Wei, "Optical orthogonal codes: Design, analysis, and applications," *IEEE Transactions on Information theory* 35, pp. 595-605, May 1989.
- [9] Zaccaran D., Kaverad M., New architecture for incoherent optical CDMA to achieve bipolar capacity, *Electronics Letters* 30(3), 1994, pp.258-259.
- [10] Hasoon F.N., Aljunid S.A., Samad M.D.A., Abdullah M.K., Shaari S., Spectral amplitude coding OCDMA using AND subtraction technique, *Applied Optics* 47(9), 2008, pp.1263-1268.
- [11] E. S. Shivaleela, K. N. Sivarajan, and A. Selvarajan, "Design of a new family of two-dimensional codes for fiber-optic CDMA networks," *J. Lightwave Technol.*, vol. 16, pp. 501-508, Apr. 1998.
- [12] Web page of optiwave (www.optiwave.com)
- [13] Hilal A. Fadhil *et. al.*, "Design considerations of high performance Optical CDMA: a new spectral amplitude code based on Laser and LED light source", *IET Optoelectronics Journal*, The Institution of Engineering and Technology, UK. vol.4, pp.29-34, Feb. 2010.

Hilal A. Fadhil received the B.Sc. degree in electronic and communications engineering from Al-Nahrain University in 2002, M.Sc. degree in communications engineering from Al-Nahrain University in 2004, and Ph.D. degree in optical communications from University Malaysia Perlis in 2010. He is currently a senior lecturer in the School of Computer and Communication Engineering, University Malaysia Perlis (UniMAP), Perlis, Malaysia. His research interests include OCDMA technologies and wavelength division multiplexing. . The author became a Member (M) of *IEEE* in 2009, and a SPIE Member in 2011.