

Investigation of Chaotic Behavior in DC-DC Converters

Sajid Iqbal, Masood Ahmed, and Suhail Aftab Qureshi

Abstract—DC-DC converters are widely used in regulated switched mode power supplies and in DC motor drive applications. There are several sources of unwanted nonlinearity in practical power converters. In addition, their operation is characterized by switching that gives birth to a variety of nonlinear dynamics.

DC-DC buck and boost converters controlled by pulse-width modulation (PWM) have been simulated. The voltage waveforms and attractors obtained from the circuit simulation have been studied. With the onset of instability, the phenomenon of subharmonic oscillations, quasi-periodicity, bifurcations, and chaos have been observed.

This paper is mainly motivated by potential contributions of chaos theory in the design, analysis and control of power converters, in particular and power electronics circuits, in general.

Keywords—Buck converter, boost converter, period-doubling, chaos, bifurcation, strange attractor.

I. INTRODUCTION

A. Chaos in Power Electronics Circuits

CHAOS is largely unpredictable long-term evolution occurring in deterministic, nonlinear dynamical system because of sensitivity to initial conditions. Power electronics circuits are rich in nonlinear dynamics. Their operation is characterized by the cyclic switching of circuit topologies, which gives rise to a variety of chaotic behavior [1-3].

Research in nonlinear systems and complexity had made remarkable progress in the last three decades, leading to discoveries which were not only new but also revolutionary in the sense that some of our traditional beliefs regarding the behavior of deterministic systems were relentlessly challenged. Most striking of all, simple deterministic systems can behave in a “random like” fashion and their solution trajectories can deny “long term predictability” even if the initial conditions are practically known. Such behavior is termed “chaos” that underlies the complexity and subtle order exhibited by real world systems. Scientists, mathematicians and engineers from diverging range of disciplines have found remarkably similar complex behavior in their systems. The root cause of such complex behavior has been identified collectively as “nonlinearity”. Precisely, without exception all systems in the real world are nonlinear [2].

B. Sources of Unwanted Nonlinearity

There are several unavoidable sources of unwanted nonlinearity in practical power electronics circuits [3]:

1. The semiconductor switching devices have intrinsically nonlinear DC characteristics: BJTs, MOSFETs, IGBTs, thyristors, diodes.
2. They also have nonlinear capacitances, and most suffer from minority carrier charge storage.
3. Nonlinear inductances abound: transformers, chokes, ferroresonant controllers, magnetic amplifiers and transconductors, and saturable snubber inductors.
4. The control circuits usually involve nonlinear components: comparators, pulse-width modulators (PWMs), multipliers, phase-locked loops (PLLs), monostables (autonomous timers) and digital controllers.

In this paper, we are concerned with power converters, which by virtue of their rich nonlinearity exhibit a variety of complex behavior.

II. CHAOS IN DC-DC CONVERTERS

Although nonlinear effects in electronic circuits were first observed by Van der Pol in 1927, it is only recently that the existence of bifurcations and chaos in power converters has been proposed [3].

DC-DC converters have always been designed to operate in only one type of periodic operation, commonly known as “period-1 operation” in which all the waveforms repeat at the same rate as the driving clock. Thus converters are expected to work stably in this regime under all possible disturbances. Anyhow, period-1 operation is not the only possibility. For instance, under certain conditions, the circuit may operate in a period-n regime in which the periods of all waveforms are exactly ‘n’ times that of the driving clock. We can immediately appreciate the complexity in the operation of switching converters, where a variety of operational regimes exist and a large number of parameters may affect the stability of a particular regime. As parameters vary, the operation can go from one regime to another, sometimes in an abrupt manner. Such a phenomenon, where one regime fails to operate and another picks up, is termed “bifurcation”. Thus even when a converter is well designed to work in a particular (desired) regime, it could fail to operate as expected if some parameters are changed, causing it to assume another regime. If the newly assumed regime is an undesirable one, locating the bifurcation boundary becomes imperative [3-4,6].

The periodic (period-1) stable operation is the preferred operation for most industrial applications; it represents only one particular operating regime. Because of the existence of many possible operating regimes, it would be of practical importance to have an exhaustive understanding of what

determines the behavior of the circuit so as to guarantee a desired operation or to avoid an undesirable one [3-7].

III. SIMULATION OF BUCK CONVERTER

This topology of buck converter is also called step down chopper because it produces an output voltage that is less than or equal to the input voltage [8].

The inductor current is always positive meaning that it is operating in a continuous conduction mode (CCM). It is mainly used in regulated DC power supplies and DC motor speed control.

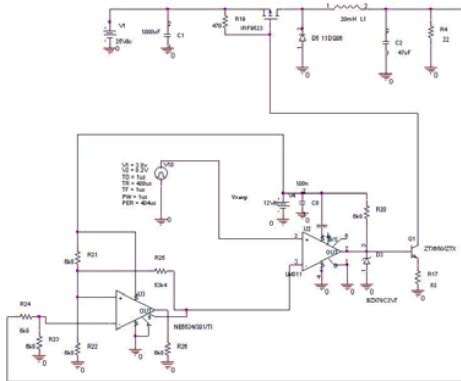

Fig. 1 PWM buck converter

The input and output relationship of this converter is:

$$V_{out} = V_{in} * D \tag{1}$$

Controlling the duty cycle D of the switch, the value of V_{out} can be kept within a desired range. The converter has PWM control of the switching. A reference voltage is compared to the output voltage and then the result is compared to a saw-tooth waveform so that corrections can be made on the value of D. By changing the input voltage (control parameter) the nonlinear dynamics (bifurcation and chaos) exhibited by this DC-DC buck converter can be investigated.

IV. SIMULATION OF BOOST CONVERTER

Fig. 2 shows boost converter also called step up chopper because it produces an output voltage that is greater than the input voltage [9]. The input and output relationship is given by:

$$V_{out} = V_{in} / (1-D) \tag{2}$$

The PWM switching in boost converter is identical to that of the buck converter. We can examine the nonlinear behavior exhibited by changing the input voltage.

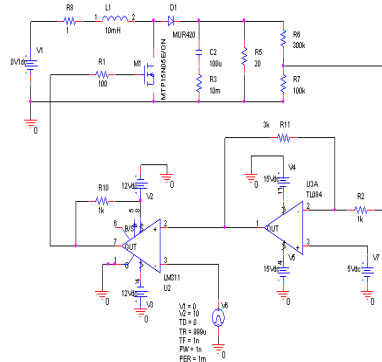

Fig. 2 PWM boost converter

V. SIMULATION RESULTS OF BUCK CONVERTER

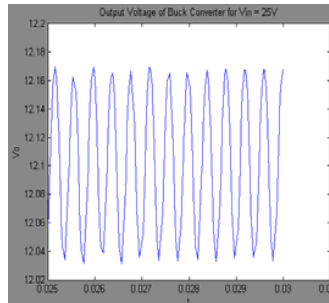

Fig. 3 Period-1 Waveform

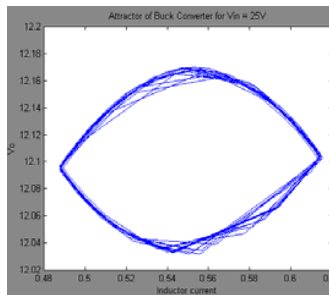

Fig. 4 Period-1 Attractor

Fig. 3 shows output voltage V_2 recorded for supply voltage $V_1=25$ volts. It can be seen that V_1 has the same period as the voltage waveform V_2 . It is periodic (period-1) operation. In this operation, all waveforms repeat at the same rate as the driving clock. The output signal waveform is almost period-1 but not exactly period-1. This could be due the improper choice of component models or due to insufficient resolution in the simulation. Fig. 4 illustrates the period-1 attractor for $V_1=25$ volts.

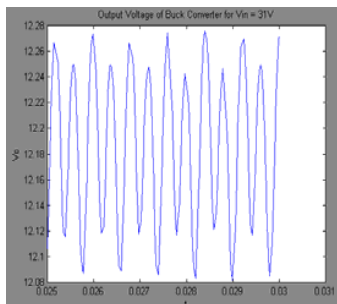

Fig. 5 Period-2 Waveform

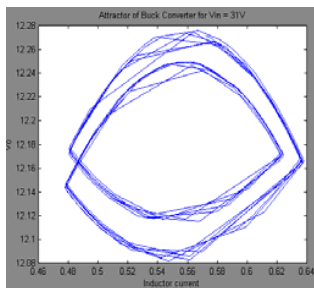

Fig. 6 Period-2 Attractor

In Fig. 5 for input voltage waveform $V_1=31$ volts, the output voltage waveform V_2 is shown. It can be observed that a period doubling has taken place: every second pulse is slightly larger than its predecessor. And Fig. 6 shows the corresponding period-2 attractor. This period-2 attractor also confirms the period doubling phenomenon.

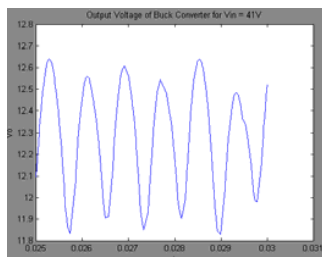

Fig. 7 Chaotic Waveform

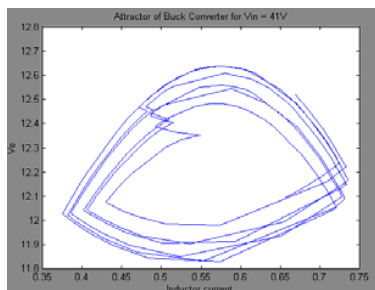

Fig. 8 Strange Attractor

Fig. 7 above demonstrates the output voltage waveform V_2 recorded when supply voltage waveform V_1 was 41 volts. This waveform is aperiodic (no more period-1 or period-2 operation). In Fig. 8, the corresponding chaotic or strange attractor (graph between output voltage and inductor current) has been drawn. These waveforms can vary a little depending upon the version of circuit simulator and the machine (computer) employed.

Thus as the input voltage has been increased from 25 to 45 volts; the operation of this simple DC-DC step down converter has transitioned by means of period doubling from periodic to chaotic operation.

Hence this simple DC-DC step up converter controlled by pulse-width modulation (PWM) exhibited periodic (period-1 and period-2) as well as aperiodic (chaotic) operations. These different types of behavior occur certainly due to a number of contributing factors as; because of intrinsically nonlinear semiconductor switching devices, nonlinear active devices, and feedback control circuits involving nonlinear components. In short, power electronic circuits can exhibit nonlinear dynamics for example bifurcations, subharmonic oscillations and chaos.

VI. SIMULATION RESULTS OF BOOST CONVERTER

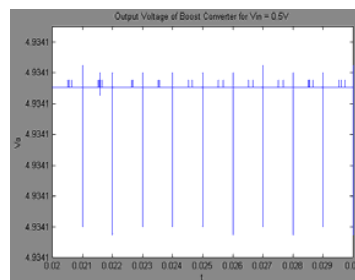

Fig. 9 Aperiodic Waveform

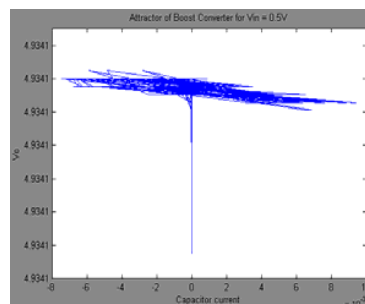

Fig. 10 Aperiodic Attractor

Fig. 9 above shows the output voltage waveform V_2 recorded when the supply voltage V_1 was 0.5 volts. The output waveform is an aperiodic signal. Fig. 10 depicts the corresponding aperiodic attractor.

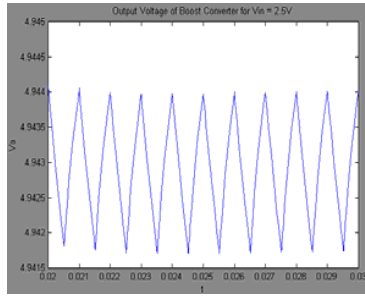

Fig. 11 Periodic Waveform

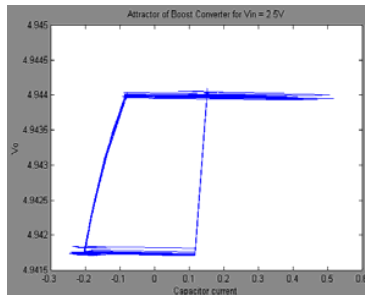

Fig. 12 Periodic Attractor

Fig. 11 above shows the periodic output voltage waveform V_2 recorded when the supply voltage $V_1=1.5$ volts. The corresponding periodic attractor is drawn in Fig. 12. So this DC-DC step up converter has shown periodic as well as aperiodic behavior.

VII. CONCLUSION

PWM buck and boost switching regulators have been simulated in a circuit simulator. These converters have wide industrial application so it is necessary for the design engineers to have a comprehensive knowledge about the circuit behavior at different regions of parameter space.

It is often difficult for the novice to grasp the fundamental concepts of nonlinear dynamics when they were represented in overly mathematical terms. But circuit simulations of nonlinear power electronics circuits allow hands-on experience of chaotic behavior in a user friendly environment with graphical output. The learning process is also enhanced by the ability to modify and experiment with the circuit parameters at will.

The practical advantage of studying chaos is a better understanding of the chaotic behavior of DC-DC converters that will lead to more reliable designs and new possibilities of operating regimes that can help optimize design.

REFERENCES

- [1] Paul S Addison. *Fractals and Chaos. An illustrated course*. IOP Publishing Limited, 1997.
- [2] Robert C. Hilborn. *Chaos and Nonlinear Dynamics. An Introduction for Scientists and Engineers*. Oxford University Press, 1994.
- [3] D. C. Hamill, S. Banerjee and G. C. Verghese, "Chapter 1: Introduction," in *Nonlinear Phenomena in Power Electronics*, edited by S. Banerjee and G. C. Verghese, New York, IEEE Press, 2001.

- [4] C. K. Tse. *Complex Behavior of Switching Power Converters*. CRC Press, 2004.
- [5] M. di Bernardo and C.K. Tse, "Chaos in Power Electronics: An Overview," *Chaos in Circuits and Systems*, Edited by G. Chen and T. Ueta, New York: World Scientific, Chapter 16, pp. 317-340, 2002.
- [6] M. di Bernardo and C.K. Tse, "Complex Behavior in Switching Power Converters," *IEEE Proceedings*. Vol 90, pp 768-781. May 2002.
- [7] S. C. Wong, C. K. Tse and K. C. Tam, "Intermittent Chaotic Operation in Switching Power Converters," *International Journal of Bifurcation and Chaos*, Vol. 14, no. 8, pp. 1971-2978, August 2004.
- [8] J.B. Deane and D.C. Hamill, "Analysis, Simulation and Experimental Study of Chaos in the DC/DC Buck Converter", *Power Electronics Specialists Conference*, pp. 491-498, San Antonio TX, 1990.
- [9] Simon S. Ang, *Power-Switching Converters*, 1st edition. Marcel Dekker, Inc., New York, 1995.