

A High Performance Technique in Harmonic Omitting Based on Predictive Current Control of a Shunt Active Power Filter

K. G. Firouzjeh, A. Sheikholeslami

Abstract—The perfect operation of common Active Filters is depended on accuracy of identification system distortion. Also, using a suitable method in current injection and reactive power compensation, leads to increased filter performance. Due to this fact, this paper presents a method based on predictive current control theory in shunt active filter applications. The harmonics of the load current is identified by using o-d-q reference frame on load current and eliminating the DC part of d-q components. Then, the rest of these components deliver to predictive current controller as a Three-phase reference current by using Park inverse transformation. System is modeled in discrete time domain. The proposed method has been tested using MATLAB model for a nonlinear load (with Total Harmonic Distortion=20%). The simulation results indicate that the proposed filter leads to flowing a sinusoidal current (THD=0.15%) through the source. In addition, the results show that the filter tracks the reference current accurately.

Keywords—Active Filter, Predictive Current Control, Low Pass Filter, Harmonic Omitting, o-d-q Reference Frame .

I. INTRODUCTION

AN unrelenting proliferation of nonlinear loads in industrial, commercial, and residential applications requires the supply of reactive power, harmonics power, and power losses pertaining to the former two. Over a period of three decades, various types of reactive power compensators have been researched and developed for power factor correction, harmonic compensation, and load balancing [1]. Due to these disadvantages, the attention of researchers has been drawn to the power filters. Traditionally, shunt passive filters comprised of tuned LC elements and capacitor banks were used to filter the harmonics and to compensate for reactive current due to nonlinear loads. However, in practical applications these methods have many disadvantages. In the last two decades, considerable progress has been made in the field of Active Filters (AFs). AFs are inverter circuits, comprising of active devices. Different topologies and control techniques have been proposed for their implementation. AFs

are superior to passive filter in terms of filtering characteristics and improve the system stability by removing resonance related problems. These filters are designed and used in several topologies such as shunt, series and shunt-series that the shunt topology is the main subject of this paper.

In recent years progression in power electronic devices with capability of high frequency switching implemented active filters with different algorithm and methods for optimizing performance of filters [1-12]. All researches with subject of active filters divided to two stages: first stage; identifying current harmonics and second stage; compensation of identified current with injection it into power network. Up to now, a lot of methods are existed for identifying and classifying parameters of network distortion which are based on analysis of time, frequency and time-frequency domain and they can recognize all network distortion. Analysis of time and frequency domain are executable in system harmonic studies, but due to these studies in [3], time analysis are suitable for study of system nonlinear situations and frequency analysis are appropriate for study of transient response of network. Due to these facts, adaptation of proper applied method with system studies will bring about great results.

All studied methods include distinguishing method on the basis of o-d-q system [4], α - β device [5], instantaneous power method, synchronous method and all methods on the basis of FFT calculations [6] of harmonic parameters of network. In addition to common techniques, some of researches are performed on the basis of nerve and fuzzy progressive algorithm [7,8]. Other groups of presented algorithm use reference frame theory that is accumulated with P-Q theory to identify load distortions. In control section and inverter switching are some nonlinear methods such as hysteresis current control [9] and linear methods such as PI controller presented on the basis of pulse width modulation [10]. Reference [11] had been present a wide research on active filters and is a proper reference.

In opposition to some methods that use a-b-c to α - β transformation or o-d-q conversion to control active filters reference [10], technically is independent of all conversions. Suggested method in [10], omits network harmonics acceptably, and also decreases the calculation volume and it is capable of executing suitably.

Among studied project with subject of active filters,

K. G. Firouzjeh is with the Faculty of Electrical and Computer Engineering, Nushirvani Technical University of Babol, P.O.Box 47135-484, Babol, Iran, (corresponding author to provide phone: 111-3232071; fax: 111-3234201; e-mail: kgorgani@stu.nit.ac.ir)

A. Sheikholeslami is with the Faculty of Electrical and Computer Engineering, Nushirvani Technical University of Babol, Iran, (e-mail: asheikh@nit.ac.ir)

references [9,12] because of simplicity of identifying harmonic spectrums of load current are acceptable. Proposed algorithm in [9] converts load current to o-d-q frame, identifies its harmonic components and then delivers to the inverter controller as a reference current. Another novel discussion which is presented in controlling of inverter current is predictive current control technique. [13-15]. Advantages of this method are modeling of nonlinear situation of system on the basis of calculating different treatments of system variants. Heretofore, predictive technique is used in the power electronics domain as a controlling system to decrement switching power loss in high power inverters. In [13,14], there is a method presented on the basis of predictive current control for voltage source inverters that increase dynamic response of inverter control system. According to the mentioned, the purposed method in this paper will be divided into two stages:

1) Identifying of load current harmonics and generation of reference current based on [9].

2) Generating reference current by voltage source inverter as active filter on the basis of predictive current control technique.

Finally, the purposed method will be test by simulation results and also the acceptable capability of identifying and omitting network distortions will be presented.

II. IDENTIFYING HARMONIC COMPONENTS OF LOAD CURRENT

Among the presented methods for identifying harmonic component of load current and network distortion, reference [9], proposed a simplified and applicable method with high performance. In [9], the measured three phase load current is transformed by using Park transform, from a-b-c to o-d-q frame:

$$\begin{bmatrix} i_{Ld} \\ i_{Lq} \\ i_{Lo} \end{bmatrix} = P \begin{bmatrix} i_{La} \\ i_{Lb} \\ i_{Lc} \end{bmatrix} \tag{1}$$

$$P = \sqrt{\frac{2}{3}} \begin{bmatrix} \cos(\theta) & \cos(\theta - \frac{2\pi}{3}) & \cos(\theta - \frac{4\pi}{3}) \\ \sin(\theta) & \sin(\theta - \frac{2\pi}{3}) & \sin(\theta - \frac{4\pi}{3}) \\ \frac{1}{\sqrt{2}} & \frac{1}{\sqrt{2}} & \frac{1}{\sqrt{2}} \end{bmatrix} \tag{2}$$

$$\theta = \theta_0 + \int_0^t \omega t dt$$

i_{La} , i_{Lb} and i_{Lc} are load currents and ω is the angular frequency.

According to the reference frame theory if three phase currents are in the form of non distortion sinusoidal in the angular frequency (ω), the outcome i_d and i_q from this transform will be constant but if network currents have

harmonic components, these values (i_q, i_d) will get variable value. In other words i_d and i_q have DC and AC terms that in this circumstance DC term includes i_d and i_q of network main frequency and AC term is derived from load current distortion. Using [9]:

$$\begin{aligned} i_d &= \bar{i}_d + \tilde{i}_d \\ i_q &= \bar{i}_q + \tilde{i}_q \end{aligned} \tag{3}$$

\bar{i}_d, \bar{i}_q are DC terms and \tilde{i}_d, \tilde{i}_q are AC terms of load current. Due to this fact, by applying high pass filter with low cut frequency (1-2 HZ) each variable part of components can be separated. Using the above filter in discrete time domain yields:

$$\begin{aligned} \tilde{i}_d(z) &= HPF(z) i_d(z) \\ \tilde{i}_q(z) &= HPF(z) i_q(z) \end{aligned} \tag{4}$$

According to this, AC terms of d-q components are caused by harmonic components of load current. So, by producing these currents using another source, we can prevent harmonic current flowing in system power source.

To achieve this purpose, $(\tilde{i}_d, \tilde{i}_q)$ currents should be transformed to a-b-c components Park inverse transform.

$$\begin{bmatrix} i_a^* \\ i_b^* \\ i_c^* \end{bmatrix} = P^{-1} \begin{bmatrix} \tilde{i}_d \\ \tilde{i}_q \\ \tilde{i}_o \end{bmatrix} \tag{5}$$

Above currents are used as compensator reference currents. In other words, these currents are applied to filter control system by means of reference current which is produced by active filters.

III. PREDICTIVE CURRENT CONTROL

A. Predictive current Control of single phase full-bridge inverter

Figure 1 shows the topology of single phase full-bridge inverter with nonlinear Inductive-Resistive load. Nonlinear treatment of load is modeled in the form of (e) potential. According to the Figure 1, the current direction is being selected conventionally in a fix direction. If switching of inverter selected as bipolar control, the switching states will be:

$$\begin{aligned} \text{State 1} &\rightarrow S_1, S_4: \text{on} & S_2, S_3: \text{off} \\ \text{State 2} &\rightarrow S_2, S_3: \text{on} & S_1, S_4: \text{off} \end{aligned}$$

Therefore, the duty cycle of S_1, S_4 switches (D) can be defined. While S_1, S_4 and S_2, S_3 are ON, the load voltage will be equal to V_d and $-V_d$ respectively.

$$D = \frac{T_{on_{1,4}}}{T} \tag{6}$$

Ton is the time that S₁,S₄ are ON in a period (T). So, in a sample the mean value of load voltage is equal to 2D-1, that:

$$(2D - 1) V_d = Ri + L \frac{di}{dt} + e \tag{7}$$

While S₂,S₃ are ON, the duty cycle is D'. According to the bipolar switching technique of single phase inverter:

$$D' = \frac{T_{on_{2,3}}}{T} \tag{8}$$

$$D = 1 - D' \tag{9}$$

By rewriting these equations in discrete time domain we have:

$$(2D_{(n)} - 1) V_d = Ri_{(n)} + L \frac{(i_{(n+1)} - i_{(n)})}{T} + e_{(n)} \tag{10}$$

$$D_{(n)} = \frac{Ri_{(n)} + L \frac{(i_{(n+1)} - i_{(n)})}{T} + e_{(n)} + V_d}{2 V_d} \tag{11}$$

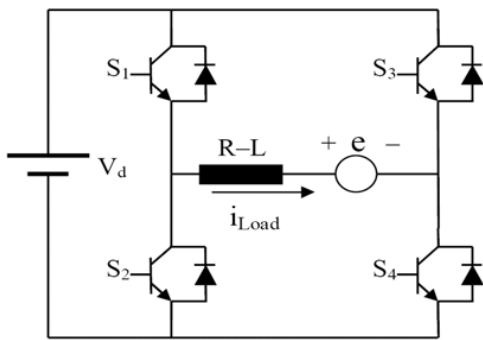

Fig. 1 Single phase full-bridge inverter with nonlinear load.

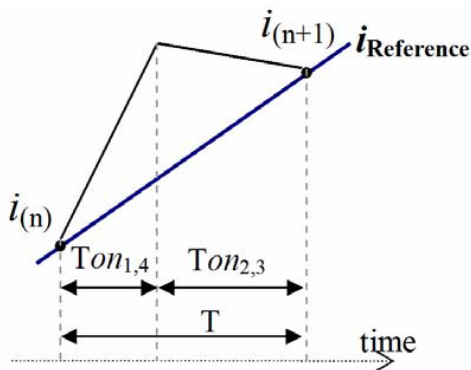

Fig. 2 Tracing of reference current in one period of T.

That $i_{(n)}$ and $i_{(n+1)}$ are currents of existing state and the next state, respectively. $e_{(n)}$ is potential of nonlinear part of load in existing state and $D_{(n)}$ is the existing state of S₁,S₄ switches in a duty cycle. According to the figure 2 with the reference current $i_{Reference}$ and considering this hypothesis that all calculations are in n-state, if S₁,S₄ are ON, the load current will increase and if not, will be decrease. Finally, the reference current can be traced by inverter where a proper value of D increases or decreases the load current. Therefore, duty cycle of $D_{(n)}$ in existing state (time of switching state 1 in a period T) changes the current from $i_{(n)}$ to $i_{(n+1)}$.

According to the PCC, duty cycle of switches determined in a way that the current $i_{(n)}$ reach to $i_{(n+1)}$. So, $i_{(n+1)}$ can be defined as a reference current and ON or OFF time of switches can be calculated in a suitable way that current of existing state reach to reference current.

B. Predictive current control of three phase inverter

Fig.3 shows the schematic circuit of three phase inverter as an active filter of nonlinear load (e_{abc}) that (R) and (L) values of filter is modeled in R-L form. In this condition, like single phase model, inverter switching states can be rewrite as:

$$\text{leg}_{-A} \begin{cases} \text{State a-1} \rightarrow S_1: \text{on} & S_2: \text{off} \\ \text{State a-2} \rightarrow S_1: \text{off} & S_2: \text{on} \end{cases}$$

$$\text{leg}_{-B} \begin{cases} \text{State b-1} \rightarrow S_3: \text{on} & S_4: \text{off} \\ \text{State b-2} \rightarrow S_3: \text{off} & S_4: \text{on} \end{cases}$$

$$\text{leg}_{-C} \begin{cases} \text{State c-1} \rightarrow S_5: \text{on} & S_6: \text{off} \\ \text{State c-2} \rightarrow S_5: \text{off} & S_6: \text{on} \end{cases}$$

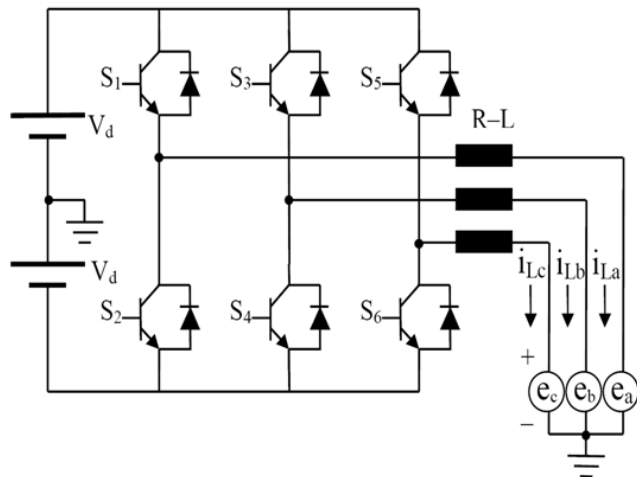

Fig. 3 Schematic circuit of shunt active filter.

Each leg of above three phase inverter is switched separately. By considering the single phase inverter equations and the load current as $i_{a,b,c}$:

$$\begin{aligned} Da V_d &= Ria + L \frac{dia}{dt} + ea \\ Db V_d &= Rib + L \frac{dib}{dt} + eb \\ Dc V_d &= Ric + L \frac{dic}{dt} + ec \end{aligned} \tag{12}$$

Da, Db, Dc are the duration of S1, S3, S5 switches in T period. These equations can be declared in discrete time domain:

$$\begin{aligned} Da_{(n)} V_d &= Ria_{(n)} + L \frac{(ia_{(n+1)} - ia_{(n)})}{T} + ea_{(n)} \\ Db_{(n)} V_d &= Rib_{(n)} + L \frac{(ib_{(n+1)} - ib_{(n)})}{T} + eb_{(n)} \\ Dc_{(n)} V_d &= Ric_{(n)} + L \frac{(ic_{(n+1)} - ic_{(n)})}{T} + ec_{(n)} \end{aligned} \tag{13}$$

These values illustrate ON and OFF time of all switches in order to change i_n to i_{n+1} . So with defining (i^*) as reference current of next state (i_{n+1}), desired switching time of each leg according to reference current can be obtained for tracing of load current.

IV. CONTROL OF ACTIVE FILTER BASED ON PREDICTIVE CURRENT CONTROL

According to the section 2, the current quantities derived from harmonic components of load current are accessible with equation (5). By assuming these currents as filter reference current, we can produce the proposed current to predictive current control of inverter on the basis of presented technique.

$$\begin{bmatrix} ia_{(n+1)} \\ ib_{(n+1)} \\ ic_{(n+1)} \end{bmatrix} = \begin{bmatrix} i_a^* \\ i_b^* \\ i_c^* \end{bmatrix} \tag{14}$$

Thus, having i_n as inverter current in progress state, e_n as load voltage of and measured current from equation (15), switching states determined in a way that the current of existing state trace reference current. To achieve this goal, it is sufficient that all values substitute in equation (13) in order to determine the duration of S1, S3, S5 switches.

Fig.4 shows the structure of a shunt active filter with applying purposed method. Applying above algorithm, three phase inverter with R-L impedance operates as network filter and eventually prepares a condition that concluded values from harmonic components of load didn't flow through

source.

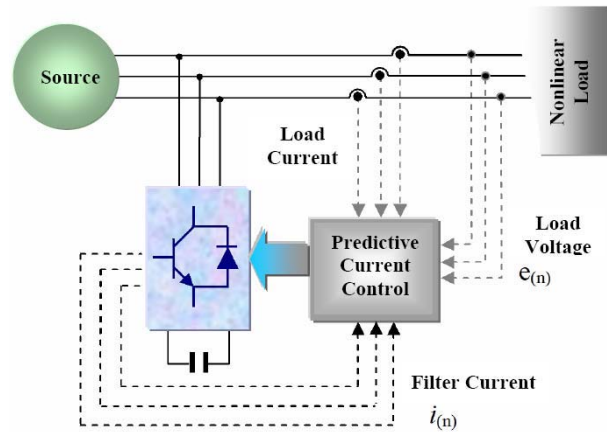

Fig. 4 Controlling block diagram.

V. SIMULATION RESULTS

The purposed method is validated by simulation results of MATLAB. Simulation parameters are shown in table I. Shunt active filter with predictive current control is applied to a nonlinear load (diode bridge rectifier) to compensate the harmonic current.

Fig.5 shows the circuit model of network in MATLAB. Harmonics of nonlinear load current (ILabc) are transforming to reference currents of each phase by reference block. Consequently, the switching block uses these reference values and filter voltage and currents and also converter DC capacitor voltage to prepare proper firing signals by a controller for inverter on the basis of predictive current control. To control DC capacitors of converter, the voltage values are delivered to controller, not only to control switching, also to keep on the voltage level in an acceptable span.

Fig.6 represents a nonlinear load current. According to this figure, the load current has improper harmonics, so by applying active filter we want to produce the harmonic part of load current and consequently have a current without distortion through source. Fig.7 and Fig.8 depict power source and active filter current after applying purposed method.

TABLE I
DESIGN SPECIFICATION AND CIRCUIT PARAMETERS

AC Source voltage	400 V
Fundamental frequency	50 Hz
Inverter DC bus voltage	540 V
Cdc capacitor	500 μF
Inverter inductance	5 mH
Inverter resistance	0.05 Ω

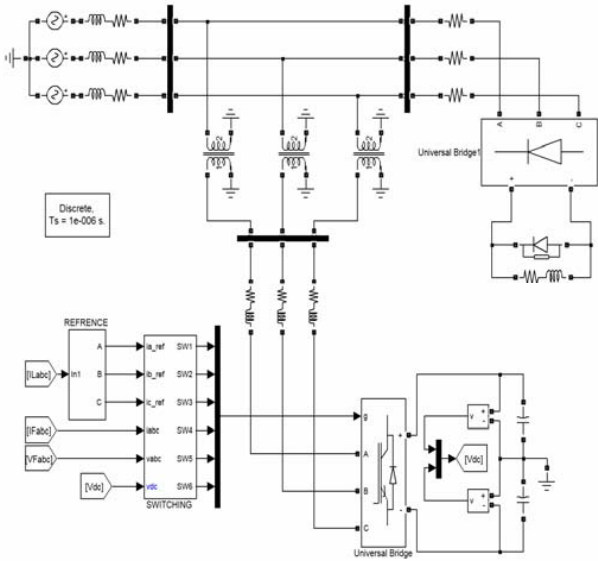

Fig. 5 Simulation model of typical network in MATLAB.

Due to Fig.7, active filter is capable in identifying and producing harmonic part of nonlinear load current. So it causes a sinusoidal current to flow through power source with negligible harmonic distortion. Analyzing active and reactive power of active filter and power source which is depicted in Fig.9 and Fig.10, it is obviously understood that only the active filter take part in production of reactive power. It shows that the filter compensates reactive power well, too. Harmonic spectrum of load and source current, are shown in Fig.11 and Fig.12 respectively. As it is illustrated, load current has relative amount of total harmonic distortion (%20.52) which applied filter, compensate harmonic parts and cause flow of perfect sinusoidal current without any harmonic distortion from source (%0.15). Fig.13 and Fig.14 show that purposed algorithm is capable in tracing reference current accurately, and also keep on the voltage level of DC capacitor in acceptable span, which it is another confirmation of predictive current control capability in active filter application with shunt topology of power networks.

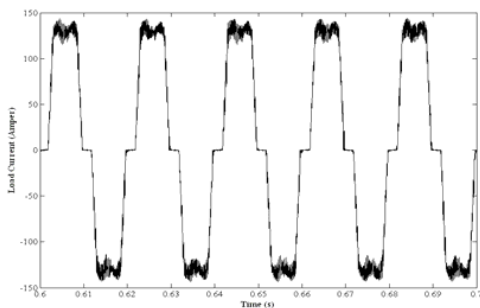

Fig. 6 Load consuming current.

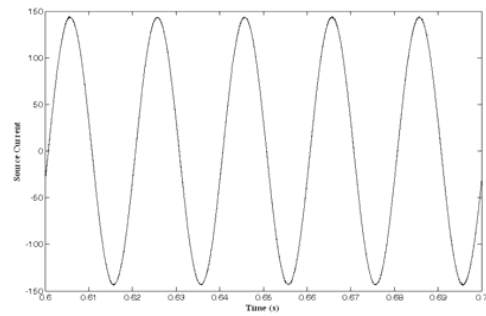

Fig. 7 Source generated current.

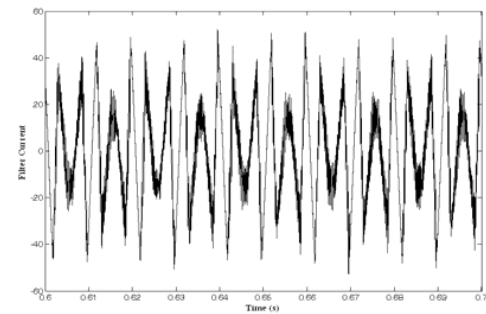

Fig. 8 Filter generated current.

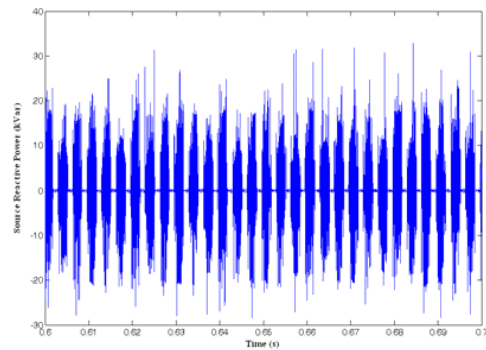
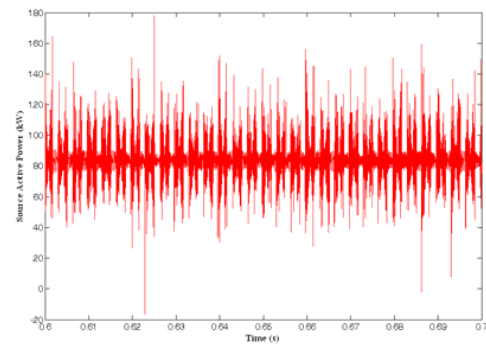

Fig. 9 Source active and reactive power.

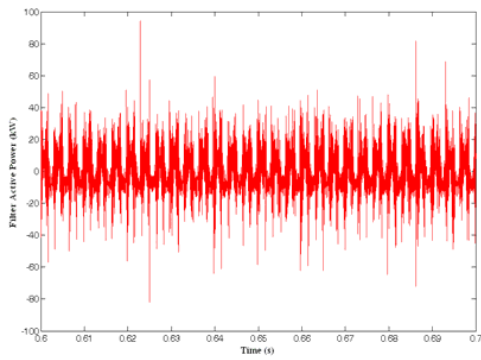

Fig. 10 Inverter active and reactive power.

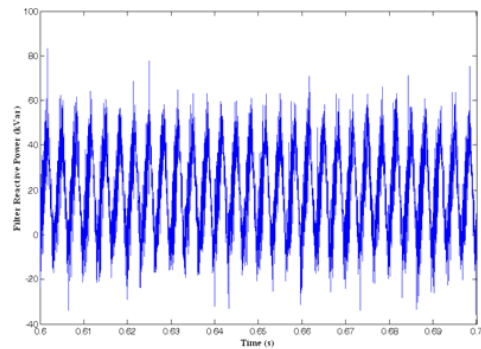

Fig. 10 Inverter active and reactive power.

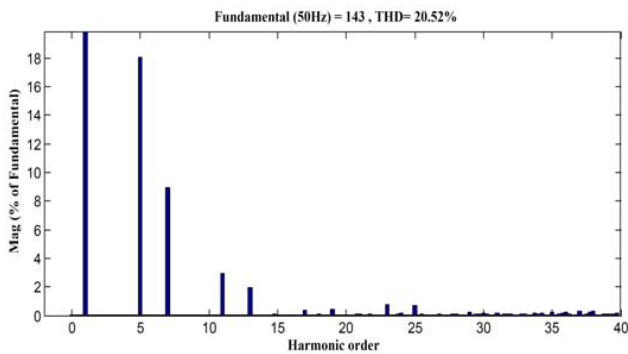

Fig. 11. Harmonic spectrum of the nonlinear load current

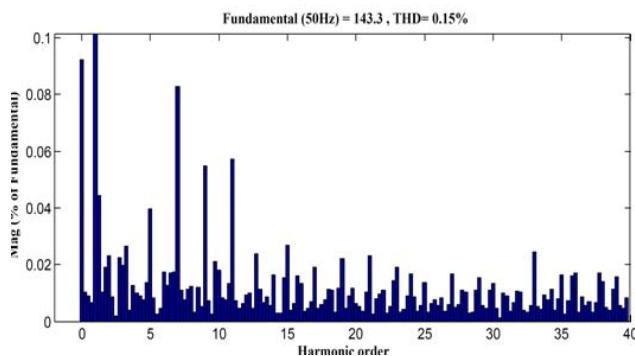

Fig. 12 Harmonic spectrum of the source current after compensation.

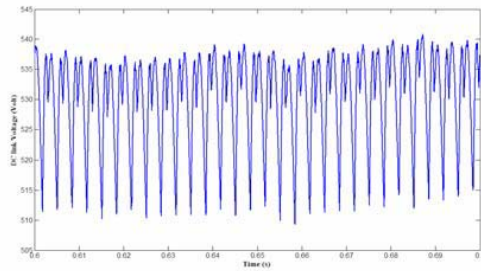

Fig. 13 DC voltage level of filter.

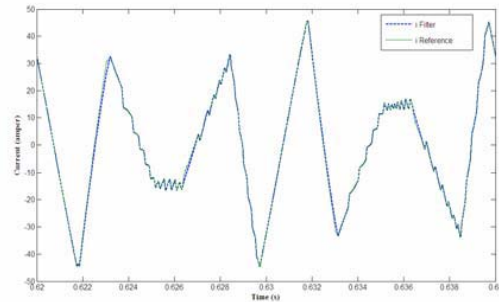

Fig. 14 Reference current tracing by filter current.

VI. CONCLUSION

Purposed method in this paper can identify and inject harmonic spectrum of nonlinear current, with high accuracy in omitting current harmonics from power source in two stages. In identification state, load current distortion is separated with acceptable response time. Applied algorithm with high accuracy has suitable implementation ratio in compare with common methods. Predictive current control technique makes inverter capable of reference current tracing by current and reactive power injection purpose. The advantage of this method is the proper performance in a wide range of harmonic frequency of load current and its independency of control limitations. Simulation results demonstrate that purposed active filter participate only in generation of consuming reactive power of network and the average of related active power is used as a compensator of zero reactive power.

REFERENCES

- [1] B. N. Singh, B. Singh, A. Chandra, P. Rastgoufard, K. Al-Haddad, "An Improved Control Algorithm for Active Filters," IEEE Trans. Power Delivery, Vol. 22, No. 2, Apr. 2007, pp. 1009 – 1020.
- [2] B. Singh, K. Al-Haddad, A. Chandra, "A review of active filters for power quality improvement IEEE Trans. Industrial Electronics, Vol. 46, No. 5, Oct. 1999, pp. 960 – 971.
- [3] K. W. Louie, P. Wilson, R. W. Wachal, A. Wang, P. Buchanan, "HVDC Power System Harmonic Analysis in the Time and Frequency Domains," PowerCon2006, Oct. 2006, pp. 1 – 8.
- [4] S. J. Lee, S.K. Sul, "A harmonic reference frame based current controller for active filter," APEC 2000, in Proc. IEEE, Vol. 2, Feb. 2000, pp. 1073 – 1078.
- [5] M. Aredes, L. F. C. Monteiro, "A control strategy for shunt active filter," 10th International Conference on Harmonics and Quality of Power, Vol. 2, Oct. 2002, pp. 472 – 477.
- [6] B. P. McGrath, D. G. Holmes, J. J. H. Galloway, "Power converter line synchronization using a discrete Fourier transform (DFT) based on a

- variable sample rate," IEEE Trans. Power Electronics, Vol. 20, No. 4, Jul. 2005, pp. 877 – 884.
- [7] Y. Wada, N. Pecharanin, A. Taguchi, N. Iijima, Y. Akima, M. Sone, "Application of recurrent neural network for active filter," International Conf. Neural Networks, in Proc. IEEE, Vol. 1, 1995, pp. 488 – 491.
- [8] M. G. Villalva, E. F. Ruppert, "Current controller with artificial neural network for 3-phase 4-wire active filter," Power Electronics Specialists Conference, 2004. PESC 04, in Proc. IEEE, Vol. 2, Jun. 2004, pp. 993 – 998.
- [9] S. Zabihi, F. Zare , "Active Power Filters with Unipolar Pulse Width Modulation to Reduce Switching Losses," PowerCon2006, Oct. 2006 .
- [10] Ajami, S. H. Hosseini, "Implementation of a Novel Control Strategy for Shunt Active Filter," ECTI Trans. Electrical Eng, Electronics, and Communications, Vol. 4, NO. 1, Feb. 2006, pp. 40-46.
- [11] L. Asiminoaei, F. Blaabjerg, S. Hansen, "Evaluation of harmonic detection methods for active power filter applications," APEC'05, vol. 1, Mar. 2005, pp. 635-641.
- [12] S. Hansen, L. Asiminoaei, F. Blaabjerg, "Simple and advanced methods for calculating six-pulse diode rectifier line side harmonics," Proc. IAS'03, Vol. 3, Oct. 2003, pp 2056-2062.
- [13] J. Rodriguez, J. Pontt, C.A. Silva, P. Correa, P. Lezana, P. Cortes, U. Ammann, "Predictive Current Control of a Voltage Source Inverter," IEEE Trans. Industrial Electronics , Vol. 54, No. 1, 2007, pp. 495 – 503.
- [14] J. Rodriguez, J. Pontt, C. Silva, P. Cortes, U. Amman, S. Rees, "Predictive current control of a voltage source inverter," Power Electronics Specialists Conference, PESC 04, in Proc. IEEE, Vol. 3, Jun. 2004, pp. 2192 – 2196.
- [15] X. Wen, F. Lin, T. Q. Zheng, "Dynamic Model and Predictive Current Control of Voltage Source Converter Based HVDC," PowerCon2006, in Proc. IEEE, Oct. 2006, pp. 1 – 5.



Khalil Gorgani Firouzjeh was born in Babolsar, Iran on September, 1981. He graduated B.Sc from the Faculty of Engineering, Mashhad University, Iran, in 2004 and M.Sc degree in Faculty of Electrical and Computer Engineering, University of Mazandaran, Iran in 2007. He is currently a PHD student in Nushirvani Technical University of Babol, University of Mazandaran. His research interests are Power system and High Voltage Protection, Fault Location and Power Electronic Joined with Power System.



Abdolreza Sheikholeslami was born in Doroud, Iran on May 1959. He graduated B.Sc in University of Mazandaran, Iran, in 1980 and M.Sc and PhD degrees in Strathclyde University, UK, in 1985 and 1988, respectively. He is currently an Assistant Professor at the Faculty of Electrical and Computer Engineering, Nushirvani Technical University of Babol, University of Mazandaran, Iran. His research interests are Power system and Power quality and Power Electronic Joined with Power System.