

# Simulation and Analysis of the Shift Process for an Automatic Transmission

Kei-Lin Kuo

**Abstract**—The automatic transmission (AT) is one of the most important components of many automobile transmission systems. The shift quality has a significant influence on the ride comfort of the vehicle. During the AT shift process, the joint elements such as the clutch and bands engage or disengage, linking sets of gears to create a fixed gear ratio. Since these ratios differ between gears in a fixed gear ratio transmission, the motion of the vehicle could change suddenly during the shift process if the joint elements are engaged or disengaged inappropriately, additionally impacting the entire transmission system and increasing the temperature of connect elements. The objective was to establish a system model for an AT powertrain using Matlab/Simulink. This paper further analyses the effect of varying hydraulic pressure and the associated impact on shift quality during both engagement and disengagement of the joint elements, proving that shift quality improvements could be achieved with appropriate hydraulic pressure control.

**Keywords**—Automatic transmission, Simulation and analysis, Shift quality.

## I. INTRODUCTION

### A. Motivation and Background

**M**ETHODS of AT control are continuously being improved in order to improve shift quality and provide better ride comfort for passengers. Shift quality depends mostly on the smoothness during the shift process. In other words, a smooth shift means there is no exorbitant instantaneous acceleration or deceleration during shifting. Since automobile powertrains contain multi-rotation inertial systems, the shift process will always take a certain amount of time. With fixed gear ratio ATs vibration and shock can occur during shifting, which results in passenger discomfort. Therefore, in order to improve the shift quality, it is important to theoretically analyze the shift performance of an AT, choose an appropriate control method, and optimize the application of hydraulic pressure.

### B. Literature Review

Since the AT emerged within the automotive industry, shift quality has been the primary focus for the characterization and evaluation of different transmissions. In recent years, thanks to rapid developments in electronic control technology, research in the field of ATs has been enhanced, with many major manufacturers around the world conducting intensive research. However, the traditional 4-speed AT cannot meet the demands of the modern customer, prompting automobile producers to develop more gear sets for ATs. For example, in 2001, Yamamoto et al developed a new Aisin 5-speed AT, which

used a new planetary gearbox resulting in a smaller size and better performance than the previous 4-speed AT. [1] In 2003, Scherer presented that compared to the earlier 5-speed AT, the total amount of components of the new ZF 6-speed AT had been reduced by 29%, the length had been shortened by 6% and the control method had been quality and the response time. [2] In 2004, Greiner et al introduced the new Mercedes-Benz 7G-TRONIC 7-speed AT, with a shorter response time and better acceleration performance than any previous AT. [3] In 2007, Kondo et al revealed the new Toyota AA80E 8-speed AT, with a 6.5% reduction in fuel consumption compared to the above 6-speed AT. [4] Using benefits derived from advanced control theory and improved electronic control technology, the modern AT has seen significant improvements in shift quality as well as fuel consumption.

## II. AT SHIFT PROCESS ANALYSIS

Shift process analysis is the key study for AT shift quality control. The automatic shift process is usually achieved through the engagement or disengagement of a number of bands and clutches. The entire shift process can be divided into two phases. The torque phase, where the speed ratio remains constant but output torque decreases, and the inertia phase, where the speed ratio changes. The shift process is complex and can be influenced by various factors. Therefore, it is necessary to develop a general mathematical model for AT shift process analysis. It is also essential to simplify the motion equation in order to establish a dynamic model for the system, and use this dynamic model to analyze and investigate the shift process [5].

### A. Torque and inertia phases in the shift process

Figure. 1 shows the curves of clutch pressure, output torque and engine speed during a gear change from 1<sup>st</sup> to 2<sup>nd</sup> Gear. [6] In this figure, the solid line and dashed line represent well and poorly controlled clutch pressure respectively.

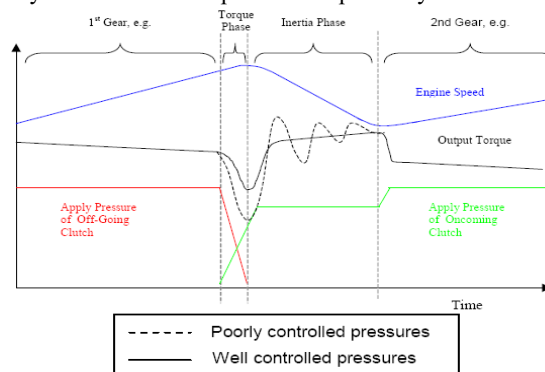

Fig. 1 Shift process analysis

K. L. Kuo is with the Vehicle Engineering Department, National Taipei University of Technology, Taiwan, ROC. (phone: 886-227712171#3623; e-mail: kkuo@ntut.edu.tw).

## (1) Torque Phase

As shown in Fig. 1, during the shift process, the applied pressure of the off-going clutch begins to decrease, but the clutch remains engaged without slip. Before the oncoming clutch applied pressure starts to increase, the clutch is affected by friction torque and begins to slip. During this phase, there is no sudden change of engine speed. The only difference in this stage is the change of torque, hence the name torque phase.

## (2) Inertia phase

In the second phase of the shift process, the off-going clutch is kept in slip until the oncoming clutch is completely engaged, as shown in Fig. 1. Since the two friction components are in slip, the output torque varies sharply as along with engine speed and ratio. Thus, this phase is defined as the inertia phase.

## (3) Torque hole and torque overshoot

From Fig. 1, output torque experienced both a trough period (lower than the torque in the original gear) and a crest period (higher than the torque in the original gear). The wave trough period is called a torque hole, while the wave crest period is called a torque overshoot. The torque hole is defined by depth and width, where the depth is the difference between minimum torque and the torque in previous gear and the width is the half value of the maximum width of the torque hole. The torque overshoot is measured by height which is the distance between the maximum torque and the original value before up-shift, as shown in Fig.2. [7].

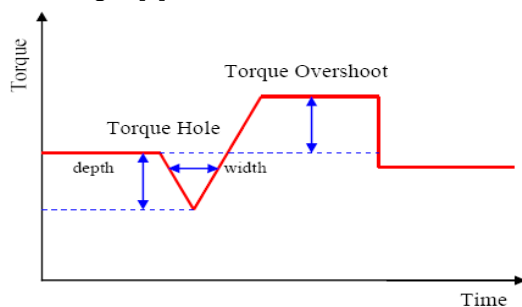

Fig. 2 Torque curve in the up-shift process

The bigger the torque hole, the larger the decrease of torque in torque phase, which results in a more significant reduction of acceleration. Since the decrease of acceleration causes discomfort for both the driver and passengers, the expected value of the torque hole should be as shallow and narrow as possible. The torque overshoot denotes the amplitude of output torque, which reflects the shock and vibration of the gear shift. Previous research shows that the application pressure of the on-coming clutch and the output torque are the most important control parameters to prevent this. In the inertia phase, the applied pressure directly controls the output torque and a higher applied pressure could lower the torque in the torque phase. Meanwhile, in the inertia phase, the torque-overshoot could be kept at an acceptable level under a relatively low hydraulic pressure; achieving better shift quality [8].

## B. The apply pressure changes in shift process

In the shift process, large steps of hydraulic pressure cause larger fluctuations in the applied pressure, thus increasing output torque vibrations. Conversely, a slower charging hydraulic pressure system generates a longer period of clutch friction, which increases wear and temperature. Thus, a shift buffer control is implemented using a pressure accumulator, valve and various other components to control the charging pressure and retard the speed of pressure increase. Sharp increases in friction torque should be avoided in order to restrict the vibration of output torque, whilst ensuring the shift period is kept short. As a result, the appropriate design of the hydraulic pressure application is crucial to the shift quality.

## III. SIMULATION MODEL DEVELOPMENT

In this paper, Matlab/Simulink was used to model an existing AT transmission system. The F4A41 4-speed AT used in the domestic-made Mitsubishi Lancer equipped with a 4G92 engine was used for this simulation. The overall vehicle weight is 1165kg, with vehicle dimensions 4420mm × 1690mm × 1395mm. The tires specified are 185/60/R14. More detailed specific features are shown in Table 1 [9] and Table 2 [10].

The Mitsubishi F4A4 AT has 5 clutches as shown in Fig. 3 [10]. These are the UD clutch, OD clutch, REV clutch, LR clutch and 2ND clutch.

TABLE I  
4G92 ENGINE SPECIFICATION

Engine Type	4G92
Cylinder Type	4 cylinders vertical engine
Bore × Stroke	81×77.5 mm
Displacement	1597 cc
Valve type	SOHC, 16V, Belt driven
Compression ratio	10 : 1
Idling speed	750±100rpm
Maximum output	115ps/6000rpm
Maximum torque	14.3kg-m/5000rpm

TABLE II  
F4A41 AT SPECIFICATION

AT Model	F4A41	
Torque converter type	3 component	
Transmission type	4 forward, 1 reverse	
Gear ratio	First	2.842
	Second	1.529
	Third	1
	Fourth	0.712
	Reverse	2.480
Transfer Ratio	4.042	

In first gear, both the LR and UD clutches are engaged simultaneously, while the 2ND and UD clutches work synchronously in second gear. Table 3 shows the clutch engagements for various gears.

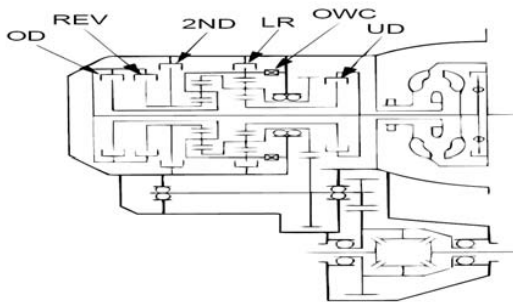

Fig. 3 Mitsubishi F4A4 AT layout diagram[10]

TABLE II  
CLUTCH ENGAGEMENT FOR DIFFERENT GEARS

	4 - Speed (Small Type)				
	Clutch				
	UD	OD	REV	LR	2ND
1 st	●			●	
2 nd	●				●
3 rd	●	●			
4 th		●			●
Reverse			●	●	

Simscape, which is embedded in the Matlab/Simulink environment, has become an important tool recently. It is a fundamental platform for modeling and simulating multi-domain physical systems. The greatest advantage of this software for users is the avoidance of complicated formula derivation through the provision of fundamental building blocks for modeling system spanning mechanical, electrical, hydraulic, and other physical domains as physical networks. Using the built-in physical blocks for the engine, hydraulic torque converter, transmission, clutch, gearbox and other domains, the simulation structure for the vehicle was then established, as shown in Fig. 4. Table 4 shows the parameters for the whole vehicle simulation.

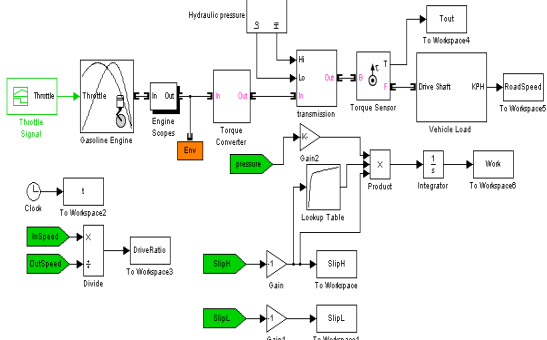

Fig. 4 Vehicle simulation structure

Figure 5 portrays the hydraulic torque converter block diagram, whose simulation parameters have been determined. The initial rotation rate of the pump impeller (engine) was 750 rpm, whilst the turbine initial rotation rate was 0 rpm. The assumptions for rotational inertia were 0.1 kg-m<sup>2</sup> for the engine and pump impeller and 0.01 kg-m<sup>2</sup> for the turbine and shaft.

TABLE III  
VEHICLE PARAMETERS FOR SIMULATION

Maximum engine power	86.64kW
Maximum rotation rate	7000 rpm
Overall weight	1165kg
Tyre radius	0.289 m
Assumed rolling resistance ratio $\mu_r$	0.01
Assumed air resistance ratio Cd	0.37
Windward area	1.96 m <sup>2</sup>
Air density	1.204 kg/m <sup>3</sup>

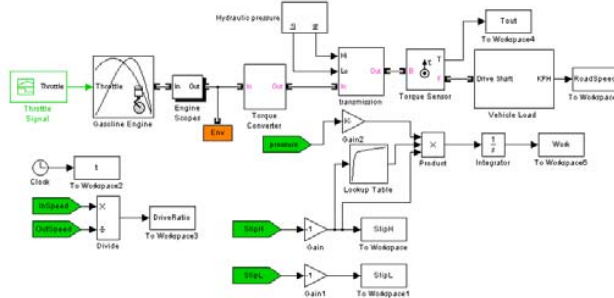

Fig. 5 Hydraulic torque converter block diagram

Figure 6 shows the block model for the transmission, where the maximum application pressure for all clutches was 1200 kPa, the effective motion radius was 0.0662 m, the first gear deceleration ratio was 2.842, the second gear deceleration ratio was 1.529, and the assumed gear rotary inertia was 0.01 kg-m<sup>2</sup>.

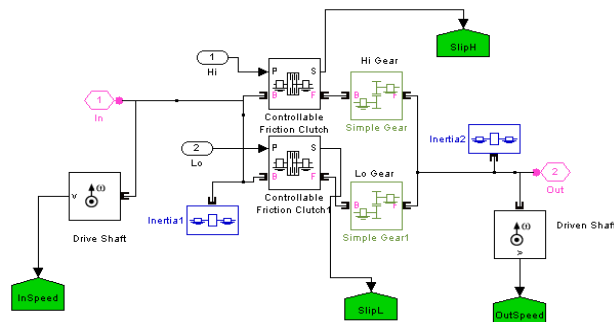

Fig. 6 Transmission block diagram

Figure 7 depicts the block diagram for the driving load, where the final deceleration ratio was 4.042, the assumed vehicle inertia was 125 kg-m<sup>2</sup>, the tier radius was 0.289 m, and the driving resistance was assumed as rolling resistance ( $R_r = \mu_r \times W$ ) and air resistance ( $R_a = C_d \times \frac{\rho}{2} \times A \times v^2$ ).

IV. SIMULATION RESULTS AND ANALYSIS

During the up-shift process for the Mitsubishi F4A4 AT, the off-going clutch alternates with the on-coming clutch. For the purposes of this paper, both were analyzed in the simulation

model separately. Firstly, the analysis of the impact of clutch pressure in the off-going element on power transmission,

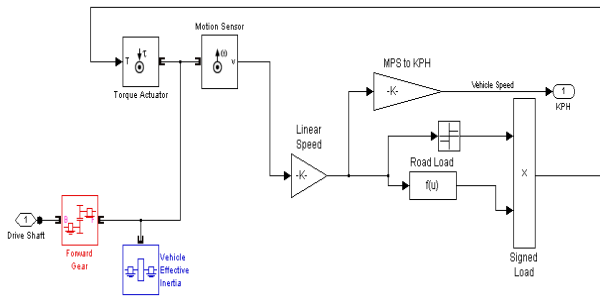

Fig. 7 Driving load block diagram

followed by the analysis of the impact of clutch pressure in the on-coming element on shift quality.

#### A. Analysis of the impact of clutch pressure in the off-going element on power transmission

As mentioned before, a bigger torque hole during up-shift generates a large torque decrease in the torque phase, which results in a significant reduction in acceleration. Thus, the torque hole should be as shallow and narrow as possible. For this simulation, the throttle position was maintained at 30%, the period of pressure increase for the high-speed gear was fixed, and the pressure releasing period for the low-speed gear was varied between 3.25 and 3.6 seconds. Under this circumstance, the low-speed clutches were off-going elements. The output torque was compared between the two different pressure release periods.

With a pressure release period of 3.25 sec, the minimum torque output was 6.6 N-m, and the maximum value was 144.2 N-m. In the torque phase, since the friction torque transferred by the clutch was much less than the engine output torque, there exists a visible lack of powertrain as shown in Fig. 8.

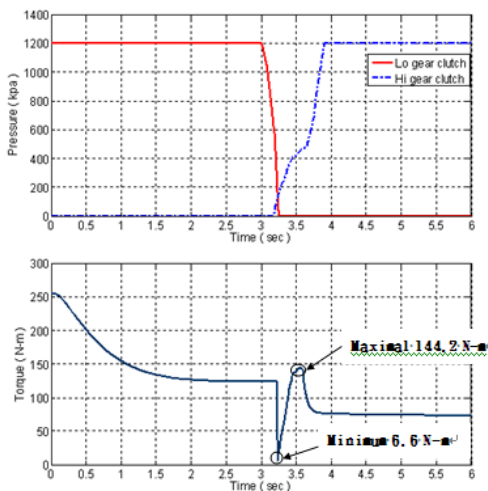

Fig. 8 Pressure and torque diagram with pressure release time of 3.25 sec

At a pressure release period of 3.6 sec, the minimum torque increased to 19 N-m. Since the time of pressure release for the

low-speed gear clutch was too long, the clutch would produce reverse torque and power backflow, causing power overlap as shown in Fig. 9.

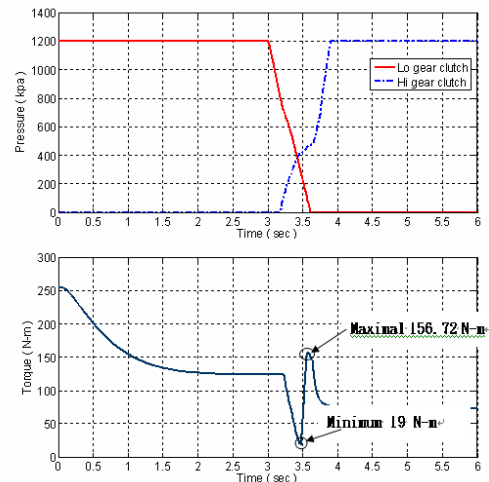

Fig. 9 Pressure and torque diagram with pressure release time of 3.6 sec

#### B. Analysis of the impact of clutch pressure in the on-coming element on shift quality

The scenario of this part simulation involved the throttle position fixed at 30% and no variation in the period of pressure increase for the low-speed gear, only changing the pressure release period for the high-speed gear. As discussed before, the output torque difference during the up-shift process would affect the shift vibration and shock. Therefore, control of the pressure increase curve might be a feasible approach to control torque overshoot, reduce shift vibration and improve shift quality. When the torque-overshoot increases, the shift vibration and shock will be more intense. The following sections will compare the shift vibration by observing and analyzing the pattern of output torque.

##### B.1 Analysis of the impacts of clutch pressure in the torque control stage

(1) When the pressure of the high gear clutch is increased too slowly in the torque control stage

The clutch friction decreases due to the pressure decrease of the low gear clutch, reducing the maximum torque. When the low gear pressure reduces below a certain level, it is unable to transfer torque from the pump impeller. Meanwhile, there is insufficient time to build pressure in the high gear clutch during the torque control stage, causing a lack of power transmission. Moreover, it results in a significant decrease of torque in the torque phase, leading to a large torque hole, as shown in Fig. 10.

(2) When the pressure of the high gear clutch is increased too quickly in the torque control stage

Since the pressure of the low gear clutch has not been released completely, while the pressure of the high gear clutch increases too quickly through fast hydraulic pressure increase, the bands start to compress, and friction torque begins to increase. The high gear clutch transfers

reverse torque to counteract the forward torque transferred

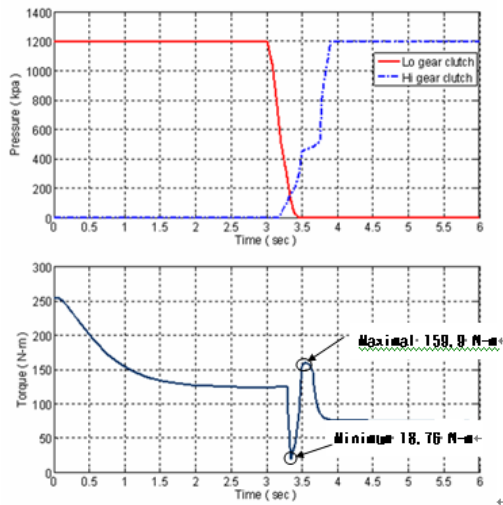

Fig. 10 Output torque curve with slow clutch pressure increase

reverse torque to counteract the forward torque transferred by the low gear clutch, resulting in over power transmission. Since “dual deadlock” caused partial power backflow is created, the output torsion decreases as well as the torque, which is unfavorable to the shift process as shown in Fig. 11.

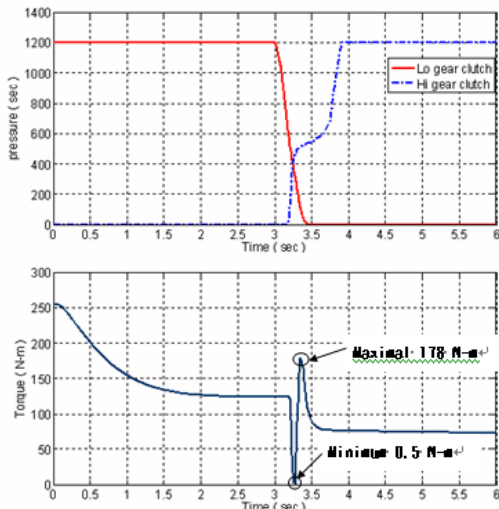

Fig. 11 Output torque curve with fast clutch pressure increase

From the above analysis, in the torque control stage, the joint elements have a significant influence on the torque phase as well as the total torque transmission. These influences were relatively smaller in the inertia phase, and thus impacted less on shift vibration and shock.

**B.2 Analysis of the impact of clutch pressure in the inertia control stage**

In the inertia phase of the up-shift process, as the pressure of the high gear clutch is increased, the torque of clutch and bands

rise until active and driven clutch plates are synchronized and engaged completely. Pressure control in the inertia phase would affect the torque overshoot, where the size of torque overshoot is represented by the amplitude of the torque wave and denotes the vibration level of the shift process. Through controlling clutch pressure in the inertia phase, the torque overshoot can be maintained at an acceptable level, resulting in improved shift quality.

**(1) No pressure control in the inertia phase**

The first situation is where the period of pressure increase for the high gear clutch is too short, i.e. there were insufficient buffers during the shift process. As Fig. 12 shows, the torque fluctuates considerably, creating intense vibrations and shock during the shift process, impacting on shift quality.

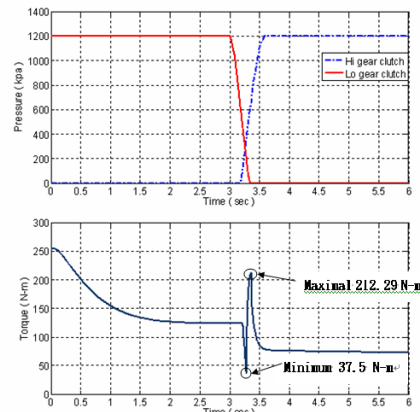

Fig. 12 Output torque curve with fast clutch pressure increase

The second situation is where the period of pressure increase for the high gear clutch is too long. Before clutch engagement, the torque increases as the pressure rises. With the sliding friction between clutch plates, the period of pressure increase and time of clutch engagement is extended as shown in Fig. 13, causing slight torque fluctuations.

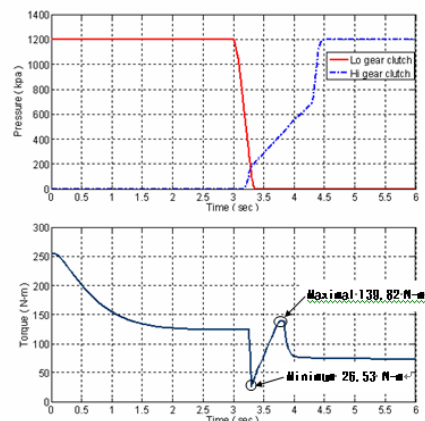

Fig. 13 Output torque curve with slow clutch pressure increase

**(2) Pressure control in the inertia phase**

Good control of the pressure increase for the high gear clutch would reduce the shift transition period and enable the joint elements to be engaged in a short period of time. It would also decrease the frictional work, and increase component life. Meanwhile, reductions in the vibration and shock during the end stage of shift process would be achieved as Fig 14 shows, smoothing the shift process and improving the shift quality.

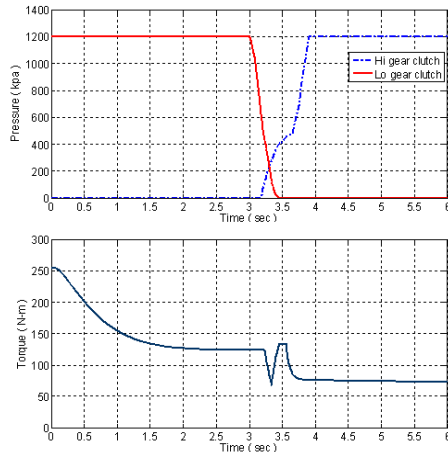

Fig. 14 Good control of the pressure increase reduce the shift transition period

### B.3 Analysis of pressure impact at the end stage of shift process

This part of the analysis observes the impact of clutch pressure on the shift vibration by changing the applied pressure of the high gear clutch at the end stage of an up-shift. Compared to Fig.14, where the end time of the up-shift process was 3.9 sec, the simulations showed in Fig. 15 and Fig. 16 were obtained by changing the end time to 3.7 sec and 4.1 sec respectively while keeping both the torque control stage and the inertia control stage constant. In the end stage of the shift process, the applied clutch pressure increases sharply to the system hydraulic pressure level. Since the clutch has already been engaged before this stage, the sudden increase of pressure does not affect the shift quality, eliminating the clutch friction. The main hydraulic pressure is normally maintained between 1.2~1.6 MPa, which is specified by the friction torque requirements of the system. As the length of this end stage is extremely short, it is not necessary to control clutch pressure change.

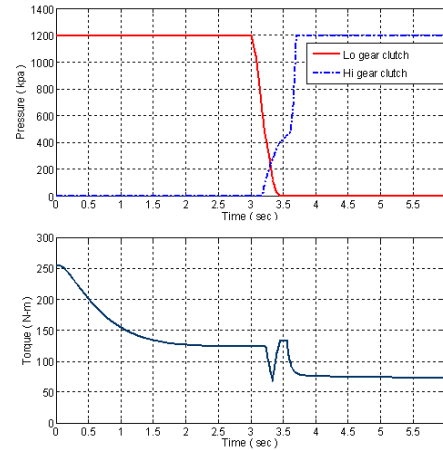

Fig. 15 Output torque curve when the end time of up-shift is 3.7 sec

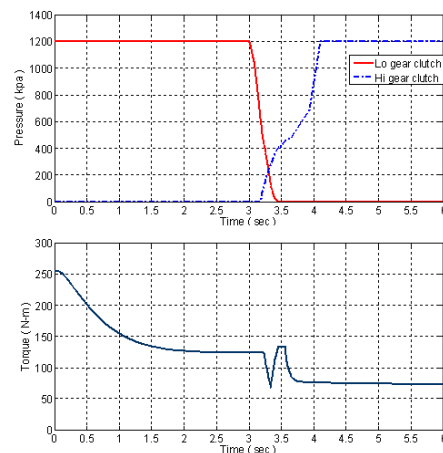

Fig. 16 Output torque curve when the end time of up-shift is 4.1 sec

## V. CONCLUSION

Within the system discussed in this research, the powertrain effects and hydraulic pressure changes during AT shift process were mainly discussed. This research has produced a simplified dynamic model for ATs, and has revealed a detailed analysis about the gearbox motion and force situations before and after shifting. In order to improve shift quality, this paper has investigated a number of timing sequences for the engagement process of joint elements, as well as control methods for hydraulic pressure during the AT shift process. This research has not only provided an intuitive understanding of shift processes, but also provided some useful results for process control, as shown in following:

- (1) During the up-shift process, the low gear clutch disengages, while the high gear clutch engages. In the torque phase, if the applied pressure of the high gear clutch increases too quickly, the low gear clutch will produce reverse torque and power backflow, which is unfavorable for the shift process. Conversely, if the pressure increases too slowly, there is a lack of friction torque from the high gear clutch, and the low gear clutch

is required to transfer friction torque, resulting in wear of the clutch plates.

- (2) During the up-shift process, the hydraulic pressure and timing in the torque phase has a direct impact on the degree of shift vibration as well as the possibility of power loss. In the inertia phase, the pressure control has an influence on the period of the inertia phase and the shift vibration.
- (3) The powertrain performance is decided by process parameters. The reason for abnormal behavior can be found among these figures, such as the change of engine rotation rate, the difference of clutch friction, the pattern of output torque, and others.
- (4) A well controlled clutch pressure would improve shift quality considerably, especially during the torque control phase and torque control stage of the inertia phase, where pressure control will directly affect the power transmission and shift vibration. After the clutch is engaged, the end stage of pressure increase has an insignificant influence on shift quality.

#### REFERENCES

- [1] Y. Yamamoto, M. Nishida, K. Suzuki, M. Saitou and H. Tsutsui: New Five-Speed Automatic Transmission for FWD Vehicles, SAE paper No.2001-01-0871(2001)
- [2] H. Scherer: ZF 6-Speed Automatic Transmission for Passenger Cars, SAE paper No. 2003-01-0596(2003)
- [3] J. Greiner, C. Doerr, H. Nauerz and M. Graeve: The New "7G-TRONIC" of Mercedes-Benz: Innovative Transmission Technology for Better Driving Performance, Comfort and Fuel Economy, SAE paper No. 2004-01-0649(2004)
- [4] M. Kondo, Y. Hasegawa, Y. Takanami, K. Arai, M. Tanaka and M. Kinoshita: Toyota AA80E 8-Speed Automatic Transmission with Novel Powertrain Control System, SAE paper No. 2007-01-1311(2007)
- [5] M.S. Wan: Close-circle Control System of Automatic Transmission, Journal of Nanjing Forestry University (Science Volume) (2004)
- [6] T. D'Anna, K. Govindswamy and F. Wolter: Aspects of Shift Quality with Emphasis on Powertrain Integration and Vehicle Sensitivity, SAE paper No. 2005-01-2303(2005)
- [7] T. W. Megli, M. Haghgooei and D. S. Colvin: Shift Characteristics of a 4-Speed Automatic Transmission, SAE paper No. 1999-01-1060(1999)
- [8] M. Jiang: Analysis of Shift Process Control of Hydraulic Automatic Transmission, Journal of Mechanical Design and Research (2005)
- [9] J.H. Hong: I-Chin Motor Information-4G9 Fuel Engine, I-CHIN Motor Technology Co. Ltd(2003)
- [10] S.H. Yu, B.L. Zhang: Lancer/Lancer virage Chasis and Body Manual, China Motor CMWSC 96110900 (1996)