

Realization of Electronically Controllable Current-mode Square-rooting Circuit Based on MO-CFTA

P. Silapan, C. Chanapromma and T. Worachak

Abstract—This article proposes a current-mode square-rooting circuit using current follower transconductance amplifier (CTFA). The amplitude of the output current can be electronically controlled via input bias current with wide input dynamic range. The proposed circuit consists of only single CFTA. Without any matching conditions and external passive elements, the circuit is then appropriate for an IC architecture. The magnitude of the output signal is temperature-insensitive. The PSpice simulation results are depicted, and the given results agree well with the theoretical anticipation. The power consumption is approximately 1.96mW at $\pm 1.5V$ supply voltages.

Keywords—CFTA, Current-mode, Square-rooting Circuit

I. INTRODUCTION

A SQUARE-ROOTING circuit has been found widely useful in analogue instrumentation and measurement systems, such as an rms. waveform calculator and a differential pressure flow meter [1]. From our survey, we found that several implementations of square-rooting circuits using different high-performance active building blocks, such as, Op-Amp with second-generation current conveyors (CCII)s [2], OTAs [3], second-generation current controlled current conveyors (CCCII)s [4], have been re-ported. Unfortunately, these reported circuits suffer from one or more of following weaknesses:

- Excessive use of the active/passive elements, especially external resistors [4-7].
- Use of a floating resistor, which is not convenient to further fabricate in IC [6-7].
- Absence of electronic controllability of output signal by electronically [5-6].

Since a low-voltage operating circuit becomes necessary as in portable and battery-powered equipments, the current-mode technique is ideally suited for this purpose more than the voltage-mode one. Presently, there is a growing interest in synthesizing the current-mode circuits because of more their potential advantages such as larger dynamic range, higher signal bandwidth, greater linearity, simpler circuitry and lower power consumption [5-8]. A reported active element, namely current follower transconductance amplifier (CTFA) [9-10], seems to be a versatile component in the realisation of a class of analog signal processing circuits. It is really current-mode element whose input and output signals are currents. In

addition, output current of CFTA can be electronically adjusted. The purpose of this paper is to introduce MO-CFTA based current-mode square-rooting circuit. The features of the proposed circuit are that; output gain can be adjusted via input bias current; magnitude of output signal is temperature-insensitive; the proposed circuit consists of only single MO-CFTA and without passive element, which is convenient to fabricate in integrated circuit architecture. The PSpice simulation results are also shown, which are in correspondence with the theoretical analysis.

II. CIRCUIT CONFIGURATION

A. Basic Concept of MO-CFTA

Since the proposed circuit is based on MO-CFTA, a little review of the MO-CFTA is given in this section. The symbol and equivalent circuit of the MO-CFTA are illustrated in Figs. 1(a) and (b), respectively. The voltage and current relationships of MO-CFTA are shown in (1)

$$\begin{bmatrix} V_f \\ I_z \\ I_x \\ I_{-x} \end{bmatrix} = \begin{bmatrix} 0 & 0 & 0 & 0 \\ 1 & 0 & 0 & 0 \\ 0 & g_{m1} & 0 & 0 \\ 0 & g_{m2} & 0 & 0 \end{bmatrix} \begin{bmatrix} I_f \\ V_z \\ V_x \\ V_{-x} \end{bmatrix}, \quad (1)$$

where

$$g_{m1} = \frac{I_{B1}}{2V_T}, g_{m2} = \frac{I_{B2}}{2V_T}. \quad (2)$$

g_{m1} and g_{m2} are the transconductances of the MO-CFTA. V_T is the thermal voltage.

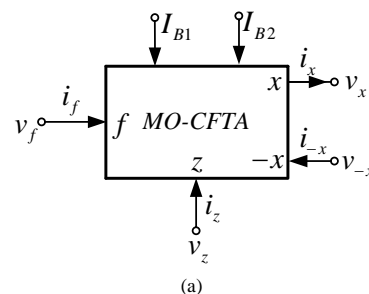

P. Silapan C.Chanapromma and T. Worachak are with the Department of Electrical Computer and Industrial, Faculty of Industrial Technology, Uttaradit Rajabhat University, Uttaradit, Thailand (e-mail: phamorn@mail.uvu.ac.th).

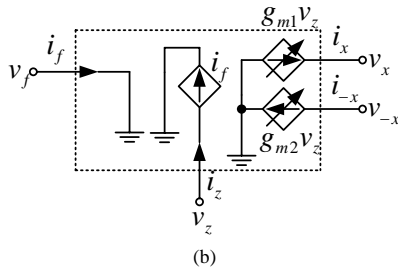

Fig. 1 MO-CFTA (a) schematic symbol, (b) equivalent circuit

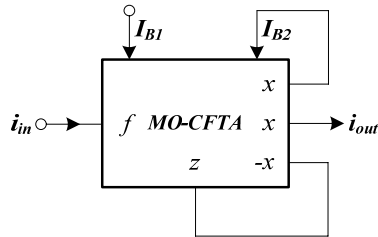

Fig. 2 Circuit diagram of current-mode square-rooter

B. Proposed Square-rooting Circuit

The proposed current-mode square-rooting circuit using MO-CFTA is shown in Fig. 2 where I_{B1} and I_{B2} are current bias currents of the MO-CFTA, respectively. By routine analysis circuit in Fig. 2 and using the properties of MO-CFTA in Section II.A, the output current at z terminal of MO-CFTA is obtained

$$I_z = I_f = I_{in}, \tag{3}$$

and

$$I_{z1} = I_{-x}. \tag{4}$$

Then the output voltage at z terminal (V_{z1}) of MO-CFTA can be found to be

$$V_z = \frac{I_{-x}}{g_{m2}} = \frac{I_{in}}{g_{m2}}. \tag{5}$$

Subsequently, the output current (I_{out}) can be expressed to be

$$I_{out} = I_{x2} = g_{m1}V_z = \frac{g_{m1}I_{in}}{g_{m2}}. \tag{6}$$

From Fig. 2, it is found that I_{out} is equal to I_{B1} . Thus, $g_{m2} = I_{out} / 2V_T$ and $g_{m1} = I_{B1} / 2V_T$. The I_{out} can be ultimately obtained

$$I_{out} = \sqrt{I_{B1}}\sqrt{I_{in}}. \tag{7}$$

From (7), it can be seen that the that the output gain can be controlled by I_{B1} . Furthermore, in ideal case, it is temperature-insensitive.

C. Non-ideal Case

In non-ideal case, the MO-CFTA can be characterized by

$$\begin{bmatrix} V_f \\ I_z \\ I_x \\ I_{-x} \end{bmatrix} = \begin{bmatrix} 0 & 0 & 0 & 0 \\ \alpha_f & 0 & 0 & 0 \\ 0 & \gamma g_{m1} & 0 & 0 \\ 0 & \gamma g_{m2} & 0 & 0 \end{bmatrix} \begin{bmatrix} I_f \\ V_z \\ V_x \\ V_{-x} \end{bmatrix}, \tag{8}$$

where α_f and γ are transferred error values, these values can be deviated from one. In the case of non-ideal and reanalyzing the proposed square rooter in Fig. 2, it yields the output current as

$$I_{out} = \sqrt{\alpha_f I_{B2}}\sqrt{I_{in}}. \tag{9}$$

From (9), it is found that the proposed square rooter still functions as a square rooter. These deviated values effect on only output magnitude. Practically, the α_f and γ originate from intrinsic resistances and stray capacitances in the MO-CFTA. These errors affect the sensitivity to temperature and high frequency response of the proposed circuit, then the MO-CFTA should be carefully designed to achieve these errors as low as possible.

III. SIMULATION RESULTS

To prove the performances of the proposed square-rooting circuit, a PSpice simulation was performed for examination. This work employed a MO-CFTA realized by a BJT technology. The PNP and NPN transistors employed in the proposed circuit as shown in Fig. 3 were simulated by respectively using the parameters of the PR200N and NR200N bipolar transistors of ALA400 transistor array from AT&T [11] with $\pm 1.5V$ supply voltages and I_A was set to $50\mu A$. Fig. 3 depicts the schematic description of MO-CFTA used in the simulations. Table I shows the parameters of BJT where it is used in the proposed circuit.

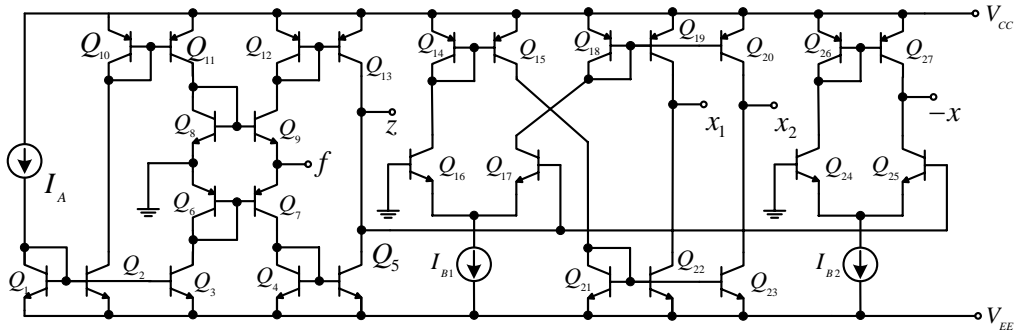

Fig. 3 Internal construction of MO-CFTA

TABLE I
PARAMETER OF BIPOLAR JUNCTION TRANSISTOR

NPN
.MODEL NR200N NPN(RB=262.5 IRB=0 RBM=12.5 RC=25 RE=0.5 +IS=242E-18 EG=1.206 XTI=2 XTB=1.538 BF=137.5 +IKF=13.94E-3 NF=1 VAF=159.4 ISE=72E-16 NE=1.713 +BR=0.7258 IKR=4.396E-3 NR=1 VAR=10.73 ISC=0 NC=2 +TF=0.425E-9 TR=0.425E-8 CJE=0.428E-12 VJE=0.5 +MJE=0.28 CJC=1.97E-13 VJC=0.5 MJC=0.3 XCJC=0.065 +CJS=1.17E-12 VJS=0.64 MJS=0.4 FC=0.5)
PNP
.MODEL PR200N PNP(RB=163.5 IRB=0 RBM=12.27 RC=25 RE=1.5 +IS=147E-18 EG=1.206 XTI=1.7 XTB=1.866 BF=110 +IKF=4.718E-3 NF=1 VAF=51.8 ISE=50.2E-16 NE=1.650 +BR=0.4745 IKR=12.96E-3 NR=1 VAR=9.96 ISC=0 NC=2 +TF=0.610E-9 TR=0.610E-8 CJE=0.36E-12 VJE=0.5 +MJE=0.28 CJC=0.328E-12 VJC=0.8 MJC=0.4 XCJC=0.074 +CJS=1.39E-12 VJS=0.55 MJS=0.35 FC=0.5)

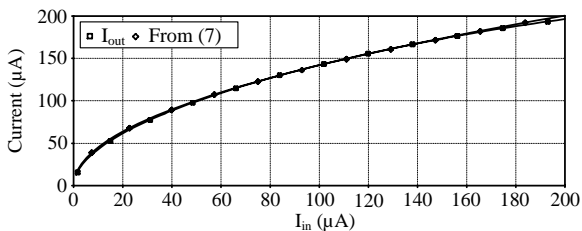

Fig. 4 DC transfer characteristic of the proposed circuit

Fig. 4 shows the DC transfer characteristic of the proposed circuit. Figs 5(a), (b) and (c) display the output signal when the frequencies of the triangle input signal are 1kHz, 100kHz and 1MHz, respectively. It is confirmed that the maximum useful frequency range is up to megahertz range without disturbing amplitude of the output current. The simulation result as shown Fig. 6 is the output current when a sinusoidal signal is applied. Fig. 7 demonstrates the output current when $I_{B1} = 120\mu A, 200\mu A$ and $300\mu A$. It can be found that the output magnitude can be electronically controlled by I_{B1} , as analyzed in (7).

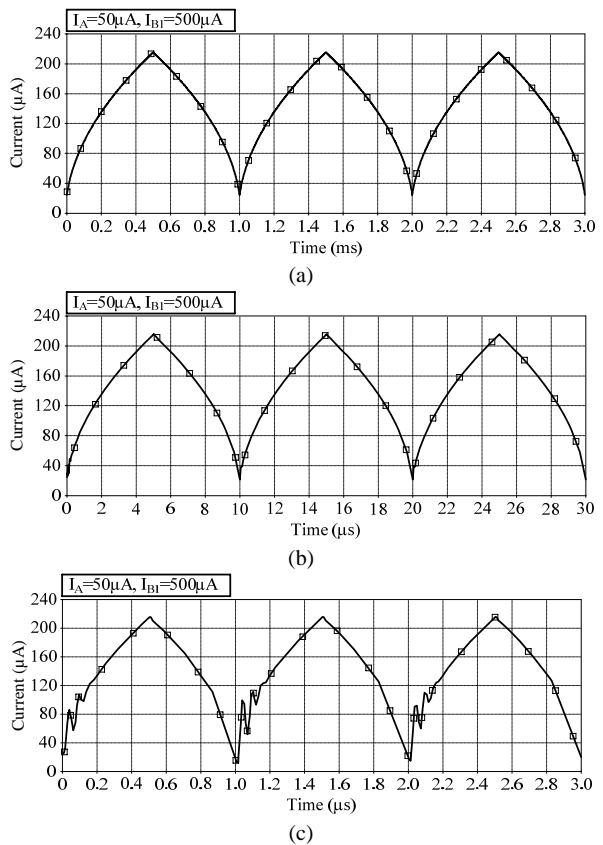

Fig. 5 The results of output current for different various input frequencies (a) 1kHz (b) 100kHz (c) 1MHz

Fig. 8 shows the output signal of the proposed circuit relative to temperature variations from $27^{\circ}C, 50^{\circ}C$ and $100^{\circ}C$. It is clearly seen that the output current is slightly dependent on the temperature variations due to the intrinsic resistances and stray capacitances in the MO-CFTA, as depicted in Section II.C. Fig. 9 depicts amplitude deviation relative to variations of the temperature from $0^{\circ}C$ to $100^{\circ}C$, it is displayed that the maximum error of the output amplitude current is approximately 0.3%.

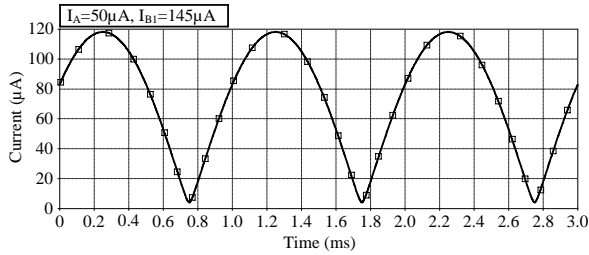

Fig. 6 The transient response of output current to a sinusoidal signal

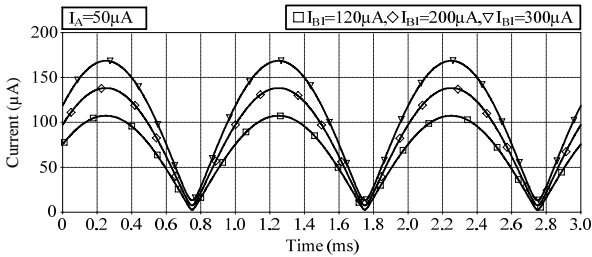

Fig. 7 The result of output current for different I_{B1}

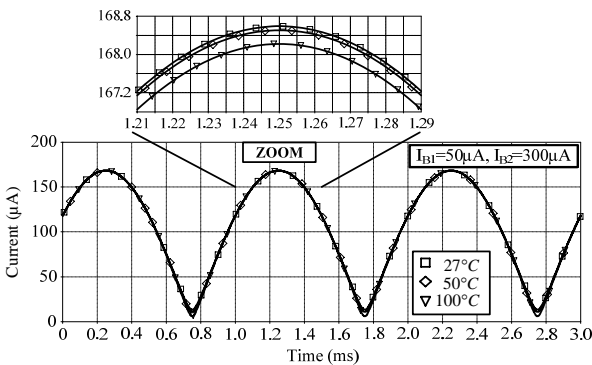

Fig. 8 The output deviations for different temperature values

IV. CONCLUSION

The current-mode square-rooting circuit based on the MO-CFTA has been presented. The features of the proposed circuit are that: output gain can be adjusted via input bias current; magnitude of output signal is theoretically temperature-insensitive; the proposed square rooter consists of only single MO-CFTA without passive element, which is appropriate to fabricate in integrated circuit architecture. The performances of the proposed circuit have been also investigated and discussed through PSpice. They show that the proposed circuit can function as a current-mode square-rooter for input current range variation from $0\mu A$ to $180\mu A$. The maximum power consumption is $1.96mW$ at $\pm 1.5V$ supply voltages. The maximum error of the amplitude of output current signal due to variations of the temperature is approximately 0.3%. Furthermore, the highest frequency is restricted at up to a megahertz range.

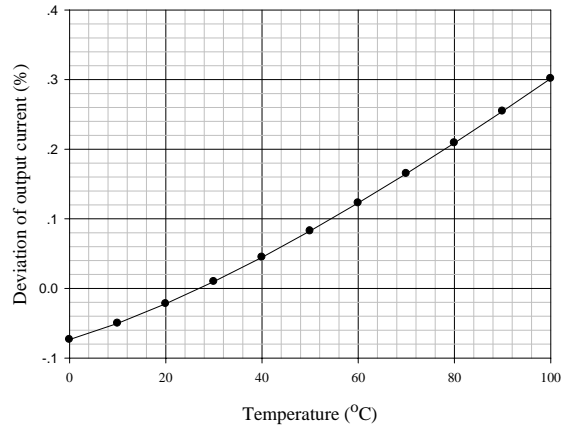

Fig. 9 The amplitude deviation of the output current for temperature variations

REFERENCES

- [1] O. E. Doebelin, Measurement Systems: Application and Design, New York: McGraw Hill, 2004.
- [2] S.-I. Liu, "Square-rooting and vector summation circuits using current conveyors," IEE Proc. Circuit., Dev. Syst., vol.142, pp. 223–226, 1995.
- [3] V. Riewruja, "Simple square-rooting circuit using OTAs," Electronics Letters, vol. 44, pp.1000-1002, 2008.
- [4] C. Netbut, M. Kumngern, P. Prommee and K. Dejhan, "New simple square-rooting circuits based on translinear current conveyors," ECTI Transactions on Electrical Eng., Electronics, and Communication, vol. 5, 10-17, 2007.
- [5] D. R. Bhaskar, V. K. Sharma, M. Monis and S. M. I. Rizvi, "New current-mode universal biquad filter," Microelectronics Journal, vol. 30, pp. 837-839, 1999.
- [6] C. Toumazou, F. J. Lidgley and D. G. Haigh. Analogue IC design: the current-mode approach, London: Peter Peregrinus, 1990.
- [7] H. Schmid, "Why the terms 'current mode' and 'voltage mode' neither divide nor qualify circuits," IEEE ISCAS, pp. II-29-II-32, 2002.
- [8] S. Khucharoenin, and V. Kasemsuwan, "High performance CMOS current-mode precision full-wave rectifier," IEEE ISCAS, pp. I-41-I-44, 2003.
- [9] N. Herencsar, J. Koton, I. Lattenberg, and K. Vrba, "Signal-flow graphs for current-mode universal filter design using current follower transconductance amplifiers (CFTAs)," In Proceedings of the Applied Electronics - APPEL'08, Pilsen, Czech Republic, pp. 113–116, 2008.
- [10] D. Bielek, R. Senani, V. Biolkova, and Z. Kolka, "Active elements for analog signal processing: classification, review, and new proposals," Radioengineering, vol. 17, no. 4, pp. 15–32, 2008.
- [11] D. R. Frey, "Log-domain filtering: an approach to current-mode filtering", IEE Proceedings of Circuit Devices Systems, vol.140, pp. 406-416, 1993..