

Design of a 5-Joint Mechanical Arm with User-Friendly Control Program

Amon Tunwannarux, and Supanunt Tunwannarux

Abstract—This paper describes the design concepts and implementation of a 5-Joint mechanical arm for a rescue robot named CEO Mission II. The multi-joint arm is a five degree of freedom mechanical arm with a four bar linkage, which can be stretched to 125 cm. long. It is controlled by a teleoperator via the user-friendly control and monitoring GUI program. With Inverse Kinematics principle, we developed the method to control the servo angles of all arm joints to get the desired tip position. By clicking the determined tip position or dragging the tip of the mechanical arm on the computer screen to the desired target point, the robot will compute and move its multi-joint arm to the pose as seen on the GUI screen. The angles of each joint are calculated and sent to all joint servos simultaneously in order to move the mechanical arm to the desired pose at once. The operator can also use a joystick to control the movement of this mechanical arm and the locomotion of the robot. Many sensors are installed at the tip of this mechanical arm for surveillance from the high level and getting the vital signs of victims easier and faster in the urban search and rescue tasks. It works very effectively and easy to control. This mechanical arm and its software were developed as a part of the CEO Mission II Rescue Robot that won the First Runner Up award and the Best Technique award from the Thailand Rescue Robot Championship 2006. It is a low cost, simple, but functioning 5-Joint mechanical arm which is built from scratch, and controlled via wireless LAN 802.11b/g. This 5-Joint mechanical arm hardware concept and its software can also be used as the basic mechatronics to many real applications.

Keywords—Multi-joint, mechanical arm, inverse kinematics, rescue robot, GUI control program.

I. INTRODUCTION

NOWADAYS, many kinds of mechanical arms are used in various applications such as in semiconductor fabrications, automobile manufacturing, various industries, medical operations, transportations, educations, or even in space missions [1][2]. There have been dramatically developments in commercial and research fields for manually control, semiautonomous, and autonomous mechanical arms.

Manuscript received February 27, 2007. This work was supported by the CEO Mission II Rescue Robot project under Grant from University of the Thai Chamber of Commerce.

Asst.Prof. Amon Tunwannarux is with the Electronics and Telecommunications Engineering Department, School of Engineering, University of the Thai Chamber of Commerce, Bangkok 10400, Thailand (e-mail: amon_tun@ utcc.ac.th).

Asst.Prof. Supanunt Tunwannarux is with the Electronics and Telecommunications Engineering Department, School of Engineering, University of the Thai Chamber of Commerce, Bangkok 10400, Thailand (e-mail: supanunt_hir@ utcc.ac.th).

One of the most important fields that mechanical arms involve and can help to save human lives is the Urban Search and Rescue field (USAR). When earthquake disasters or building collapses happen, the rescue robots can bypass the danger and expedite the search for victims immediately. These robots can help to reduce personal risk to workers by entering the unstable structures, access the ordinarily inaccessible voids and extend the reach of USAR specialists to go places that were otherwise inaccessible [3]. Robots can assess structural damage in remote locations where the operators cannot see. They can carry temperature, carbon monoxide, LEL (explosive limit), oxygen, pH level, radiation and weapons of mass destruction sensors on board in order to conduct atmospheric reading and hazardous materials detection and analysis to warn the rescue personnel. During the search they can deposit radio transmitters to be able to communicate with victims, use small probes to check victim's heart rate and body temperature and supply heat source and small amounts of food and medication to sustain the survivors.



Fig. 1 CEO Mission II rescue robot with 5-Joint mechanical arm

There is the need to develop the leading edge high-technology enabling the system with autonomy, which comes with high cost and many unsolved research issues. On the other hand, there is the need for simple, cost-effective systems to be dispensable. Dispensable robots can be risked in searching for survivors in unstable structures and confined spaces. From this perspective, the domain of rescue robots is significant scientific contributions toward the development and it is also well suited for education. A lot of rescue robot competitions have been held lately with the main purpose of encouraging students and researchers to share and develop their robots for practical usage in the real situations. The most popular rescue robot contest is the World RoboCup Rescue Robot League Competition, which started in 2001 [4]. This competition is one of the inspirations for Thailand Rescue Robot Championship to be held in 2004.

In this paper, we design and implement a 5-Joint mechanical arm with a four bar linkage, including the user-friendly control/monitoring program for a rescue robot, named CEO Mission II as shown in Fig. 1, which competed in the Thailand Rescue Robot Championship 2006. This 5-Joint mechanical arm provides capability to look over the partitions and solves the problem of forward access or high level access due to more degree of freedom than the high mast of CEO Mission I [5]. It can be stretched to 125 cm long, and equipped with CCD cameras and many sensors at the tip of mechanical arm for surveillance and getting the vital signs of the disaster victims. Based on Inverse Kinematics concept [6], this robotics arm is designed with five degree of freedom and controlled by a teleoperator selecting the desired tip position of the mechanical arm on computer screen, then the servo angles of all arm joints are computed and move simultaneously to get to the pose and the determined tip position as seen on the GUI screen. It is a low cost but functioning 5-Joint mechanical arm which is built from scratch, and controlled via wireless LAN 802.11b/g. It is the first 5-Joint mechanical arm with a four bar linkage and at that time the only multi-joint mechanical arm implemented on rescue robot and make advantage in the challenging environment of the Thailand Rescue Robot Championship 2006 as in Fig. 2. Its hardware concept and software can also be applied to other mechatronics research and applications.



Fig. 2 Thailand Rescue Robot Championship 2006 competition arena

Topics covered in the following sections are as follows. Section 2 presents an overview of CEO Mission II. Section 3

explains the design concepts of our 5-joint mechanical arm. Section 4 illustrates the software on the teleoperator station, which is a real-time control and user friendly interface controlling and monitoring program. Section 5 shows the testing results and discussion. Section 6 is the conclusions and the future works.

II. AN OVERVIEW OF CEO MISSION II RESCUE ROBOT

Our 5-Joint mechanical arm with a four bar linkage, including the user-friendly control/monitoring program, was designed for CEO Mission II rescue robot in Fig. 1. The criteria of design this rescue robot is based on Thailand Rescue Robot Championship Competition rules 2006 [7]. They are the international rules, which will be used in the World RoboCup Rescue Robot Championship 2007, held in Atlanta, USA [8]. The aim of this competition is to produce lifesaving rescue operations in a large scale city disaster. Its focus is on testing robotic control, manipulation and co-operation on a mock disaster area simulating an urban area of a couple of blocks as shown in Fig. 2. The competition rules and scoring metric both focus on the basic Urban Search and Rescue (USAR) tasks of identifying live victims, determining victim condition, providing accurate victim location, and enabling victim recovery, all without causing damage to the environment. All teams compete in several missions (three different arenas) lasting twenty minutes with the winner achieving the highest cumulative score from all missions.

CEO Mission II rescue robot was designed as a track wheel type with double front flippers for climbing over the collapse and the rough terrain. The 5-Joint mechanical arm equipped with cameras and sensors at the tip are installed on the top of the robot body in order to get the bird-eye view surveillance and easier access to victims to get their vital signs. At the remote station, the robot locomotion and mechanical arm movement are controlled by joystick and user-friendly GUI control/monitoring program on computer via IEEE 802.11b/g WiFi. Robot traveling map and obstacle map are shown on the teleoperator's monitoring screen with the camera image and vital sign information getting from the robot. The design of our 5-Joint mechanical arm can be categorized into hardware challenges which include mobility, mechanics, and control method and software challenges which include user interface, control, vision, mapping and navigation.

III. DESIGN CONCEPTS OF THE MECHANICAL ARM

In order to look over the partitions and solves the problem of forward access or bird-eye view access, our mechanical arm is design to be a five degree of freedom mechanical arm, which is more effective than the two degree of freedom high mast of CEO Mission I [5]. This mechanical arm does credit to the CEO Mission II rescue robot. It helps the robot to explore in many ways such as, from high level, going into narrow space and able to get vital signs of victims easier and faster. Under simple and low cost circumstance, the 5-Joint mechanical arm is implemented with a four bar linkage at the

second joint as see in Fig. 1. Fig. 3 shows the drawing of mechanical arm which has 5 degrees of freedom.

The four bar linkage makes the mechanical arm to be stable and having a good benefit in control. The angle of four bar link is used as a manual trim forward/backward controlling parameter of robot head. It is very useful when we want to gradually move robot head forward to the victim for sensing the victim's vital signs.



Fig. 3 Multi-joint mechanical arm with five degree of freedom in variety positions

Because the pay load at the tip of arm is small and the arm structure weight is not much, servo motor with gear set still can regulate the joint angle quite well. Resistor potentiometer is installed for each joint angle feedback. Size, part number of servo motors and gear reduction ratios of each joint are shown in Table I.

TABLE I
DETAILS OF MULTI-JOINT MECHANICAL ARM

Joint No.	Name of Joint	RC Servo Part No.	Torque@ Servo (kg.cm)	Gear Reduction Ratio
1	Base	HS-815BB	24.7	22.75
2	Four bar link	HS-815BB	24.7	22.75
3	Elbow	HS-815BB	24.7	9.0
4	Tilt	HS-945MG	11.0	5.0
5	Pan	HS-945MG	11.0	1.0

In Fig. 4, the gear set of each joint and part assembly drawing are illustrated.

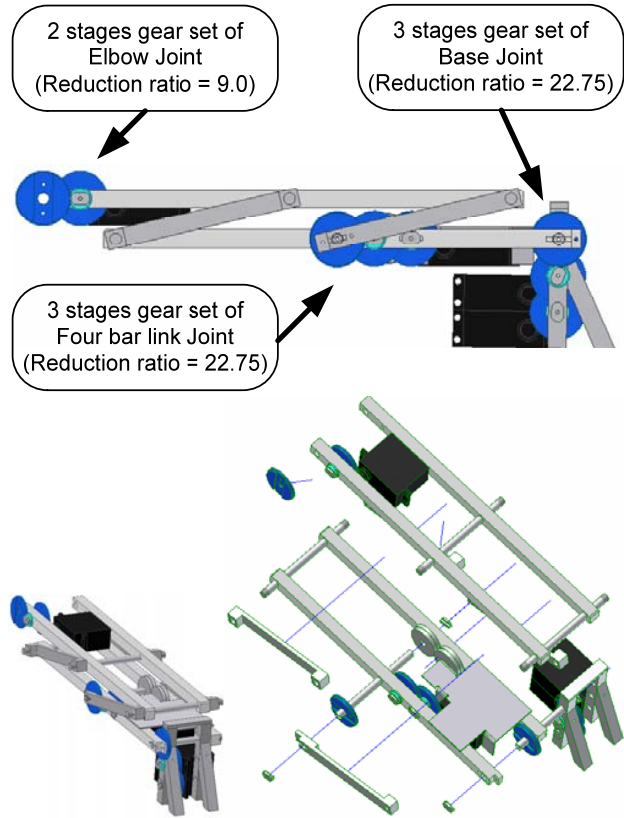

Fig. 4 Gear set of each joint and part assembly

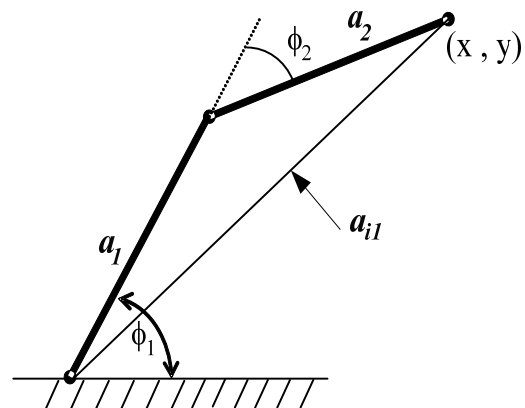

Fig. 5 Geometric for 2-joint arm calculation

Inverse kinematics is used to calculate the angle of all arm joints by the known target position of mechanical arm tip [6]. From Fig. 5, the geometric calculation of cosine rule is applied for calculating the angles of two-joint arm. So we can get the angle of link a_1 (ϕ_1), the angle of the link a_2 (ϕ_2) as the following equation (1) and (2). Then we can use these two basic equations to calculate the joint angle of each couple links.

$$\phi_2 = \arccos\left(\frac{x^2 + y^2 - a_1^2 - a_2^2}{2a_1a_2}\right) \quad (1)$$

$$\phi_1 = \arcsin\left(\frac{a_2 \sin(\phi_2)}{\sqrt{x^2 + y^2}}\right) + \arctan\left(\frac{y}{x}\right) \quad (2)$$

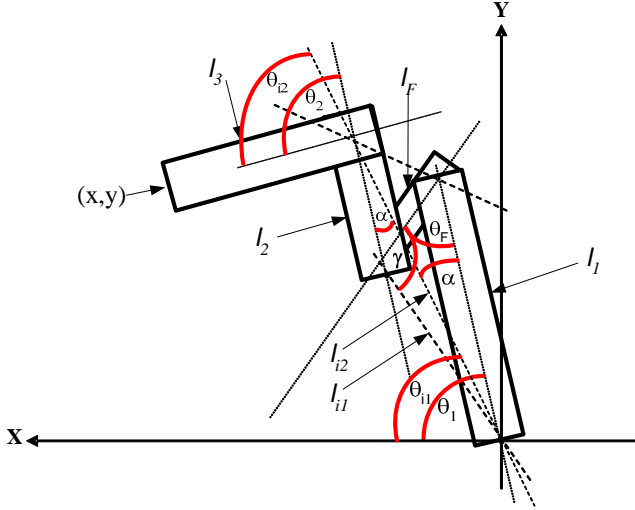

Fig. 6 Geometric of 3-joint arm and its parameter notation

Parameter notation in Fig. 6 is defined and has the details as following.

(x,y) = the 3rd link tip coordinate in Cartesian system

l_1 = length of the 1st link

l_F = length of the four bar link

l_2 = length of the 2nd link

l_3 = length of the 3rd link

l_{i1} = length of imaginary line from the base of the 1st link to the tip of four bar link

l_{i2} = length of imaginary line from the base of the 1st link to the tip of the 2nd link

θ_1 = angle between 1st link and base

θ_2 = angle between 2nd link and 3rd link

θ_F = angle between four bar link and 1st link

θ_{i1} = angle between l_{i1} and base

θ_{i2} = angle between l_{i2} and l_3

α = angle between l_2 and l_{i2} or angle between l_1 and l_{i2}

γ = angle between l_F and l_{i1}

l_1, l_F, l_2, l_3 are the given parameters which depend on mechanical arm design. The (x,y) coordinate is determined for the desired target point. Because θ_F is reserved for manual

trim forward/backward controlling of mechanical arm tip so θ_F is another given parameter. Therefore θ_1 and θ_2 can be derived by the following steps.

1. Find the l_{i1} from l_1, l_F and θ_F by the cosine rule as the equation (3).

$$l_{i1}^2 = l_1^2 + l_F^2 - 2l_1l_F \cos \theta_F \quad (3)$$

2. Find γ from l_{i1}, l_1 and l_F by the cosine rule as the equation (4).

$$\gamma = \arccos\left(\frac{l_1^2 - l_{i1}^2 - l_F^2}{2l_{i1}l_F}\right) \quad (4)$$

3. Find the l_{i2} from l_{i1}, l_2 and $\theta_F + \gamma$ by the cosine rule as the equation (5).

$$l_{i2}^2 = l_{i1}^2 + l_2^2 - 2l_{i1}l_2 \cos(\theta_F + \gamma) \quad (5)$$

4. Use inverse kinematics equation, (1),(2) to find θ_{i1} and θ_{i2} from l_{i2}, l_3 and (x, y) then those are the following

$$\theta_{i2} = \arccos\left(\frac{x^2 + y^2 - l_{i2}^2 - l_3^2}{2l_{i2}l_3}\right) \quad (6)$$

$$\theta_{i1} = \arcsin\left(\frac{l_3 \sin(\theta_{i2})}{\sqrt{x^2 + y^2}}\right) + \arctan\left(\frac{y}{x}\right) \quad (7)$$

5. Find α from l_2, l_{i1} and l_{i2} by the cosine rule as the equation (8).

$$\alpha = \arccos\left(\frac{l_{i2}^2 + l_2^2 - l_{i1}^2}{2l_{i2}l_2}\right) \quad (8)$$

6. Find θ_1 from the equation (9).

$$\theta_1 = \theta_{i1} + \alpha \quad (9)$$

7. Find θ_2 from the equation (10).

$$\theta_2 = \theta_{i2} + \alpha \quad (10)$$

To move the 5-Joint mechanical arm to any desired tip positions, as in Fig.3, the θ_1 and the θ_2 need to be derived from the above equations with given parameter θ_F .

IV. SOFTWARE ON THE TELEOPERATOR STATION

For USAR tasks, an effective user interface (UI) must be centered on providing the human operator sufficient information to make correct decisions about future actions of the robot at the required level of decision-making [9]. The user must be able to easily monitor the robots' orientation, location and power, operate various equipments such as cameras, lights and gripper on-board and precisely control robots movements as well as receive images from cameras.

Thus, the software on the teleoperator station is one of challenging research fields.

In this paper, we will illustrate only the software involving the control and monitoring robot arm movement. The CEO Mission II control and monitoring software on the teleoperator station are details in its project report [10]. By using Inverse Kinematics, the method of determining tip position in 2D coordinating system to control the movement of this mechanical system is implemented with visual basic. The flowchart of mechanical arm control program can be illustrated as in Fig. 7. The Graphic User Interface (GUI) for the CEO Mission II mechanical arm is shown in Fig. 8. The user-friendly control and monitor GUI is developed for easier usage. By clicking the determined target point or dragging the tip of the mechanical arm on screen to the desired target, the robot will move its arm to the pose as seen on the GUI screen. The angles of each joint are calculated and sent to all joint servos simultaneously in order to move the mechanical arm to the desired position. The operator can also use the joystick to control the movement of mechanical arm and the locomotion of the robot.

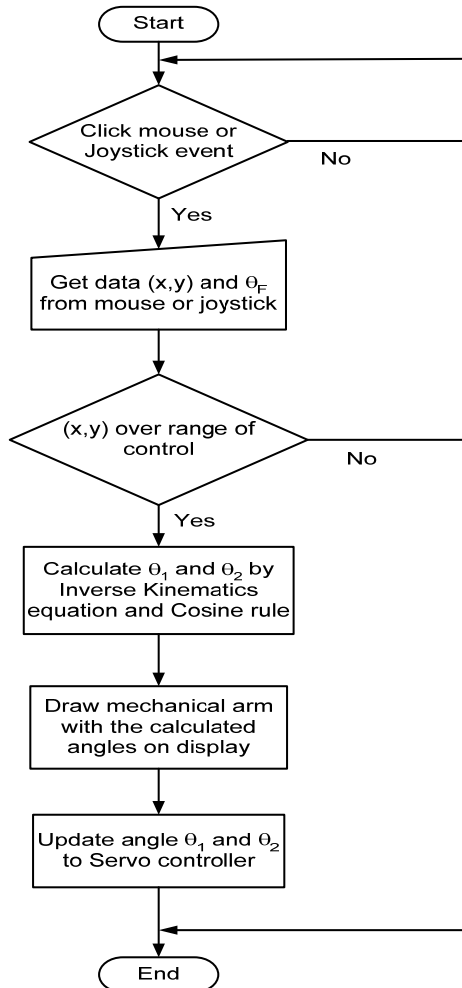

Fig. 7 Flowchart of mechanical arm control program

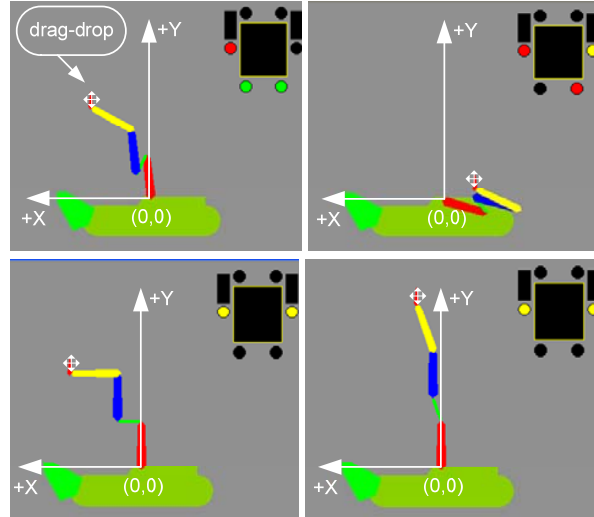

Fig. 8 Drag-drop control and monitor display for multi-joint mechanical arm in variety positions with its coordinate system

TABLE II
EXPERIMENT FOR POSITION CONTROL OF MECHANICAL ARM TIP

Position No.	Desired Target Point (x,y) : (cm,cm)	Actual Target Point (x,y) : (cm,cm)	Error (%)
1	(-10,5)	(-10.5,4)	(5,-20)
2	(-20,20)	(-20.5,18)	(2.5,-10)
3	(5,40)	(5.2,36)	(4,-10)
4	(5,60)	(5.2,57)	(4,-5)
5	(5,100)	(5.3,98)	(6,-2)
6	(47,70)	(48,67)	(2.1,-4.3)
7	(47,47)	(48,45)	(2.1,-4.3)
8	(55,90)	(56.5,86)	(2.7,-4.4)
9	(70,30)	(71.5,27)	(2.1,-10)
10	(80,20)	(82,16)	(2.5,-20)

V. TESTING RESULTS AND DISCUSSION

After the 5-joint mechanical arm installed on top of CEO Mission II robot body and its user-friendly control/monitoring GUI program were built, they worked quite well. The position control of the mechanical arm tip testing was also performed, and had the results as in Table II. We can see that there is a little backlash because the coupling of each gear is not fit enough. From the experimental results, the error of vertical position (Y axis) is more than the error of horizontal position (X axis) because of the moment of inertia and the gravity. However, it still works well on victim surveillance and the victim's vital sign detection, because the mechanical arm has light weight and this kind of work does not require high precision for position control. For further improvement, the reduction ratio of gear set of elbow joint (the 3rd joint) should be increased to 22.75 (3 stages).

All functions were tested and had very satisfied results, as in the Thailand Rescue Robot Championship 2006, CEO Mission II got the First Runner Up award and the Best Technique award.

VI. CONCLUSIONS AND FUTURE WORK

The 5-Joint mechanical arm which is built from scratch, and controlled via wireless LAN 802.11b/g with a user-friendly control/monitoring program has been briefly described. Though based on the relatively simple technique, it led to the first and at that time the only mechanical arm for a rescue robot that has 5-Joint robot arm with a four bar linkage, allows fruitful combination of surveillance jobs and victim situation navigating in the challenging environment of the Thailand Rescue Robot Championship 2006. It has been tested in many areas and competitions. Its performance was observed to be excellent. The 5-Joint mechanical arm hardware concept and its software can also be used as the basic mechatronics to many other real applications. In the future, by changing the servo motors to the higher power ones and attaching the grippers, we can adapt this mechanical arm to use in Explosive Ordnance Disposal (EOD) robot.

REFERENCES

- [1] The Canadarm : Remote Manipulator System (RMS), Available: <http://ffden-2.phys.uaf.edu/211.web.stuff/Adamczak/rms.htm>
- [2] G. Hirzinger, N. Sporer, M. Schedl, J. Butterfass, M. Grebenstein, "Robotics and mechatronics in aerospace," *The 7th International Workshop on Advanced Motion Control*, 2002, pp. 19-27.
- [3] B. Shah, and H. Choset, "Surveys on Urban Search and Rescue Robotics," Carnegie Mellon University, 2005.
- [4] World RoboCup. Available: <http://www.robocup.org/>
- [5] A. Tunwannarux, S. Hirunyaphisutthikul, "Design features and characteristics of a rescue robot," *Proceedings of International Symposium on Communications and Information Technologies (ISCIT)*, 2005.
- [6] C. Zhou, "Robot motion analysis – Kinematics," 1999. Available: <http://www2.isye.gatech.edu/~czhou/MOTION.pdf>
- [7] Thailand Rescue Robot Championship Competition rules 2006. Available: <http://www.tr.s.or.th>
- [8] World RoboCup 2007. Available: <http://www.robocup-us.org/>
- [9] J. G. Blicth, "Artificial Intelligence Technologies for Robot Assisted Urban Search and Rescue," *Expert Systems with Applications*, vol. 11(2), 1996, pp 109-124.
- [10] A. Tunwannarux, S. Tunwannarux, "CEO Mission II rescue robot project report", UTCC, 2007.