

Statistical Analysis of Different Configurations of Hybrid Doped Fiber Amplifiers

Inderpreet Kaur, Neena Gupta

Abstract—Wavelength multiplexing (WDM) technology along with optical amplifiers is used for optical communication systems in S-band, C-band and L-band. To improve the overall system performance Hybrid amplifiers consisting of cascaded TDFA and EDFA with different gain bandwidths are preferred for long haul wavelength multiplexed optical communication systems. This paper deals with statistical analysis of different configuration of hybrid amplifier i.e. analysis of TDFA-EDFA configuration and EDFA – TDFA configuration. In this paper One-Way ANOVA method is used for statistical analysis.

Keywords—WDM, EDFA, TDFA, hybrid amplifier, One-way ANOVA.

I. INTRODUCTION

WAVELENGTH multiplexing (WDM) technology along with optical amplifiers is used for communication. The semiconductor laser pumped erbium doped fiber amplifiers (EDFA) is used to provide gain in 1550nm wavelength region.

The Er3+ doped optical fiber amplifier (EDFA) has attracted a very considerable attention in the field of optical fiber communication since its gain band coincides with the third telecommunications window of silica fiber at a wavelength of 1550 nm. Erbium is a rare earth element of Lanthanides series having atomic number 68(Z=68). Now a day Erbium is used as a dopant into a glass host fiber and then this doped fiber is used as an amplifying medium. EDFA gives an amplified output around 1550nm. Being economic and reliable, EDFAs are revolutionizing the light wave systems. It has high gain and its performance is better as compared with other similar amplifier. These amplifiers can be used for wavelength ranging from 1330nm to 1580nm. Optical amplifiers amplify the power of light wave signals without conversion of signals in electrical domain. This process is independent of operating data rate and can be used for Wavelength multiplexing channels in single mode optical fibers. The use of an increasing number of channels in the present day dense wavelength multiplexing (DWDM) optical networks requires a flat gain spectrum across the whole usable bandwidth. Hybrid amplifiers with different gain bandwidths are indensible for long haul wavelength multiplexed optical communication systems in C-band and L-band. It requires broadening as well as flattening of gain spectrum of hybrid amplifier.

Inderpreet Kaur is with Electronics Engineering Department, Punjab Technical University, R.B.I.E.B.T, and Kharar, India.

Neena Gupta is with Electronics Engineering Department, Punjab Engineering College, Chandigarh.

This broaden spectrum will allow enough number of multiplexed channels to be amplified which is the basic need of WDM systems. There are different ways to increase the gain bandwidth of optical amplifiers. The aim of this research work is to examine statistically different configurations of hybrid amplifier i.e. analysis of TDFA-EDFA configuration and EDFA–TDFA configuration. In this paper One-Way ANOVA method is used for statistical analysis of these hybrid amplifiers.

II. RELATED WORK

The Er3+ doped optical fiber amplifier (EDFA) has attracted a very considerable attention in the field of optical fiber communication since its gain band coincides with the third telecommunications window of silica fiber at a wavelength of 1550 nm. The gain spectrum of EDFA is very irregular with a sharp peak at around 1530 nm and a broad band with a reduced gain at longer wavelengths. This irregularity is due to the stark splitting of the ground and meta-stable levels in the Erbium doped glass. To be used in present day long haul systems, the bandwidth of the amplifier has to be large enough to allow enough number of multiplexed channels to be amplified. This can be done if the gain spectrum of the amplifiers can be flattened by one way or the other. There are many ways of flattening the gain of EDFAs.

A. Changing the glass composition

By altering the composition of silica glass, the gain spectrum can be broadened. In 1996, an experiment was conducted to obtain an EDFA which has a gain spectrum independent of wavelength. The EDFA used was a low Al content (1% by weight) alumino-germanosilicate EDF. The system was analyzed for five wavelengths of 1542.3, 1544.7, 1548.1, 1551.0 and 1552.4 nm. It was found that the gain was flat to within ± 0.3 dB for the wavelengths between 1542-1552 nm range.

B. Long Period Fiber Grating Filters

Mendez and Ali used dual stage EDFA, long-period fiber grating filters and dispersion compensating fibers in two configurations for a 64 channel WDM system ranging from 1535.2 nm (channel 1) to 1560.4 nm (channel 64). SNR of 14.5 dB is achievable for both the configurations.

C. Acousto-optic Tunable Filters

Two acousto-optic tunable filters when used in series along with a dual stage EDFA can provide a gain flatness of 0.7 dB over a 35 nm bandwidth .An electronic feedback loop

consisting of AOTFs can also be used to automatically adjust the profile of the active gain equalizing filter so as to equalize the output signal powers to a desired value.

D. Dual Core Fiber

The use of a twin core fiber is also a choice for gain flattening in which both the cores are identically doped with Erbium. This technique involves concatenation of a length of single core EDF with a twin core EDF.

E. Microbended Long Period Fiber Gratings

Another method for flattening the gain spectrum of erbium-doped fiber amplifiers (EDFAs) is based on microbending the long-period fiber gratings that are simply fabricated by bending the fiber. Earlier FBGs were manufactured using UV based fabrication method. But it takes long time and requires capital intensive equipment

F. Rotationally Symmetric Crossed Gratings

This method involves adjusting the fiber and grating parameters to obtain desirable coupling interactions between the forward-propagating core mode and the backward-propagating cladding modes. The coupling interactions amongst cladding modes, and forward-propagating core-cladding interactions are neglected since these are comparatively smaller.

G. Hybrid Amplifiers

The bandwidth of the amplifier can be increased by using a hybrid configuration of optical amplifiers. A 1.5 dB gain flatness can be obtained by using a hybrid amplifier consisting of a distributed Raman Amplifier pumped at two wavelengths along with an EDFA. Fourteen 2.5 Gbps signals spanning 65 nm were successfully transmitted over 900 km using fifteen amplification stages.

H. Fiber Based Loop Mirror

A fiber based loop mirror (FLM) can also serve as a filter used for gain flattening purpose. In 2005, an over-coupled coupler with a free spectral range of 140 nm was used with a conventional SMF-28 fiber to form an all-fiber loop. By suitable control of the orientation of the loop, the ASE spectrum of the EDF could be flattened within ± 0.5 dB over a wavelength range in excess of 30 nm in the C-band.

I. Two stage EDFA

It is reported that when a two-stage EDFA which accurately controls each stage's pump power and the attenuation of the voltage-controlled attenuator with 50 ms response time is experimented, then wide flat gain, low noise figure, and wide dynamic range of EDFA is obtained. This arrangement is suitable for WDM network. The noise figure of the two-stage EDFA is less than 4.5dB. It is nearly insensitive

to wavelength because the first stage is highly inverted and its gain is about 13 dB.

J. Ultra Band EDFA

Y.Sun had demonstrated that an ultra wide band EDFA with a two section split structure gives a total 3dB bandwidth of 84.3nm and its maximum operating gain is 25dB. And the noise Fig. is about 6 dB.. The output power is very high at 25dB, which is required for large numbers of WDM channels.

K. New Materials for Fiber Optic Amplifiers

It is observed that the gain window of erbium amplifiers perfectly overlaps the low-loss window of silica transmission fiber. An Al/Si composition has enabled deployment of gain flattened amplifiers with bandwidth up to 32nm which can be doubled to 64nm by a split band configuration in which a so called conventional or C-band (approx 1532-1564nm) is paired with a long or L-band (approx 1574-1606nm).

The gain spectrum of EDFA has been broadened if cascaded hybrid configuration is used. This is one of the effective ways to broaden the gain spectrum of optical fiber amplifiers. Hybrid amplifiers are proposed for satisfying the growing need for increasing the transmission capacity of WDM systems. These amplifiers can be used for wavelength ranging from 1330nm to 1580nm [1-10]. Depending upon requirements, these amplifiers can be used either as pre amplifier or as in-line amplifier or as post amplifier. When Thulium doped fiber amplifier (TDFA) is cascaded in series with erbium doped fiber amplifier (EDFA), then gain spectrum of this hybrid amplifier broadens within wavelength ranges from 1460-1560nm [11-12]. The TDFA are used in S-band. There are many pumping schemes for TDFA. It is observed that the gain of amplifier be independent of the wavelength being amplified due to many reasons such as number of WDM channels to be amplified can be more and the spectral width of the source need not be critical in the case of single channel systems etc. It was observed that when TDFA is cascaded with EDFA, then the total gain of hybrid amplifier is given as product of gain of TDFA and gain of EDFA. The gain of TDFA is given as :

$$GT(\lambda) = \exp[(\sigma T(1480)NT2 - \sigma T(1390)NT1 - \sigma T(800)NT0)](\eta TLT) \quad (1)$$

The gain of EDFA is given as:

$$GE(\lambda) = \exp[(\sigma E(1530)NE2 - \sigma E(1480)NE1)(\eta ELE)] \quad (2)$$

This means the total gain of hybrid amplifier is given as shown in Eq. 3 below:

$$GT(\lambda) = GT(\lambda)XGE(\lambda) \quad (3)$$

$$\exp[(\sigma T(1480)NT2 - \sigma T(1390)NT1 - \sigma T(800)NT0)](\eta TLT)]X \exp[(\sigma E(1530)NE2 - \sigma E(1480)NE1)(\eta ELE)]$$

In the above equations, $\sigma T(1480)$, $\sigma T(1390)$ and $\sigma T(800)$ denotes cross-sections of excited state absorption, stimulated emission and ground state emission of TDFA. Similarly, $\sigma E(1530)$, $\sigma E(1480)$ represents the respective cross sections of EDFA. ηT and ηE represents the confinement factors of TDFA and EDFA respectively. With this configuration we get a wide bandwidth spectrum of nearly 100nm i.e. from 1460nm to 1560nm wavelength range. This also includes the 1510nm-1520nm range where EDFA as well as TDFA has no large gain for themselves. This is also observed that this gain is unflattened mainly from 1520nm to 1540nm region. when EDFA-TDFA configuration is implemented then the total gain of hybrid EDFA-TDFA amplifier is given by equation (4):

$$G1(\lambda) = GE(\lambda)XGT(\lambda) \quad (4)$$

$$\exp[(\sigma E(1530)NE2 - \sigma E(1480)NE1)(\eta ELE)]X \exp[(\sigma T(1480)NT2 - \sigma T(1390)NT1 - \sigma T(800)NT0)](\eta TLT)]$$

III. METHODOLOGY FOLLOWED

The aim of this research work is to examine statistically the various features of different configurations of hybrid doped fiber amplifiers. We design our hypothesis such that we support the null hypothesis. Then we decide the statistics technique to use. Before applying any specific technique, we have to first define the null hypothesis and alternative hypothesis. There are mainly two types of hypotheses: the null hypothesis and the alternative hypothesis the null hypothesis and alternative hypothesis in a very simple and expressive manner. The null hypothesis and alternative hypothesis are applicable in cases when the null hypothesis and alternative hypothesis have explanatory power. Then hypothesis testing is done. Hypothesis testing means to tell whether or not the hypothesis seems to be valid. In this paper hypothesis is so designed that the null hypothesis is supported. For that we have to make a statement. In this case we state our hypothesis as under:

A. Null hypothesis

Ho Difference in properties of TDFA-EDFA amplifier and EDFA-TDFA amplifier is a matter of chance.

B. Alternative hypothesis Ha

Difference in properties of TDFA-EDFA amplifier and EDFA-TDFA amplifier is not a matter of chance.

We support our hypothesis by comparing the calculated and tabulated value of F-ratio by using One-Way ANOVA [13-

15]. Here, One- Way ANOVA is used to test for significant difference among sample means, because two groups are tested simultaneously. For this analysis, it is assumed that the data is normally distributed and the standard deviations are equal. Analysis of Variance is shown in Table I using One-Way ANOVA.

TABLE I
ANALYSIS OF VARIANCE USING ONE WAY ANOVA

Source of variation	D.F	Sum of squares	Mean squares	F-ratio
Treatment (columns)	(c-1)	SS(Tr)	MS(Tr)= SS(Tr)/(c-1)	MS(Tr)/MSE
Blocks (rows)	(r-1)	SS(BI)	MS(BI)= SS(BI)/(r-1)	MS(BI)/MSE
Error	(c-1)(r-1)	SSE	MSE= SSE/(c-1)(r-1)	
Total	(c.r-1)	SST		

The above F-ratio for treatment and blocks is used to judge whether the difference among different parameters is significant or just is a matter of chance [18-21].

IV. ANALYSIS & RESULTS

In this paper, statistically analysis of TDFA-EDFA hybrid amplifier and EDFA-TDFA hybrid amplifier is done. The configuration TDFA-EDFA means the hybrid amplifier in which TDFA is in first stage and EDFA is in second stage, whereas configuration EDFA-TDFA means EDFA is in first stage and TDFA is in second stage. For this analysis, we assumed that both fibers have step refractive index homogeneously broadened spectrum of thulium and erbium ions. We consider three levels of TDFA i.e. 3H6, 3H4 and 3F4, the other two levels of TDFA i.e. 3H5 and 3F2,3 are ignored as the rate of their non radiation (τ_{nr}) to the corresponding levels are very high. Similarly, in case of EDFA, two levels 4I15/2, 4I13/2 is considered and level 4I11/2 is ignored for the same reasons. The energy level diagram of EDFA and TDFA were mentioned in our earlier work [12] are shown in Fig. 1 and Fig. 2 respectively. Fig. 3 and Fig. 4 represent the emission and absorption spectra of EDFA and TDFA respectively. From Fig. 3 and 4, it is clear that the absorption and emission peaks of EDFA coincides at 1530nm, while the absorption peak of TDFA lies at 1430nm and emission peak of TDFA lies at 1460nm. Fig. 5 shows the gain spectrum of EDFA, from which it is clear that EDFA has peak gain at 1530nm, beyond which the gain reduces slightly and remains flat almost until 1550nm. After that gain reduces sharply. This gain can be flattened by cascading TDFA with EDFA. Fig. 6 shows the flattened gain spectrum of Hybrid amplifier by cascading TDFA and EDFA. Fig. 7 shows the flattened gain spectrum of Hybrid amplifier by cascading EDFA and TDFA. For TDFA-EDFA hybrid amplifier,

thulium doped fiber (TDF) in first stage was forward pumped with a 1390nm pump lased diode (LD) and erbium doped fiber (EDF) in second stage is pumped with a 980nm LD. For efficient amplification the concentration of TDF +3 ions was kept very high (approx. 7500 ppm) [16-17]. Table II shows the different characteristics of both configurations.

TABLE II
FEATURES OF TDFA-EDFA & EDFA-TDFA AMPLIFIERS

Feature	TDFA-EDFA	EDFA-TDFA
Gain	25 dB for 1456nm-1556nm Range	20 dB for 1485nm-1550nm Range.
Noise Figure	<6Db	<7dB

F-ratio is calculated for the parameters mentioned in above Table II. The calculated and tabulated value of F-ratio is shown in Table III.

TABLE III
F-MEASURE RESULTS

Source of variation	D.F	SS	MS	F-ratio	Tabulated F-ratio (1,2)
Between samples	1	1.5	1.5	.05	18.51
Within Samples	2	39.6	29.9		
Total	3	41.1			

The table III shows that the F-ratio is significant of 5% level which means that both hybrid configurations work differently. F-ratio is used to judge whether the difference among several sample means is significant or just a matter of sampling fluctuations. MS residual is always due to fluctuations of sampling and so serves as the basis for the significance test. The F-ratio is compared with its corresponding table value for the given degree of freedom at a specified level of significance. The table 3 shows that both the F-ratios are significant of 5% level which means that TDFA-EDFA amplifier work differently as compared with EDFA-TDFA amplifier.. The gain spectrum of TDFA-EDFA is more widened as compared to that of EDFA-TDFA configuration. Since there is a large difference between the calculated and the table value of F. so, we reject the null hypothesis. We can very strongly say that for WDM systems, TDFA-EDFA has a great impact as a hybrid amplifier as compared with EDFA-TDFA amplifier.

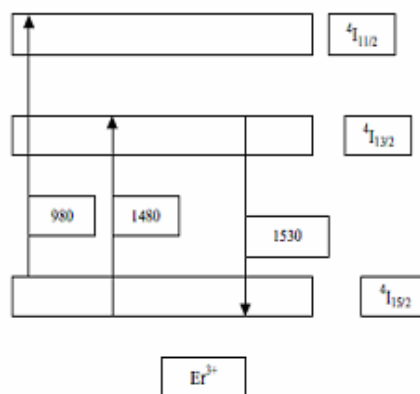

Fig. 3 Energy Level of Er³⁺

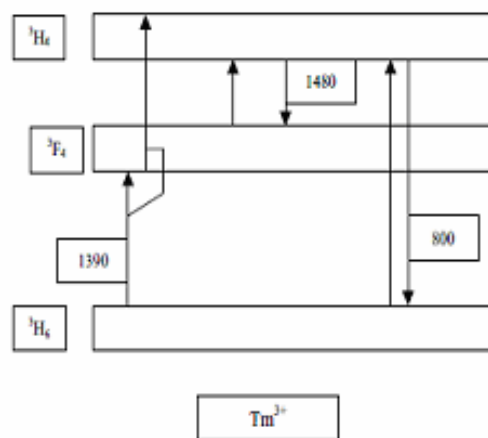

Fig. 2 Energy Level of Tm³⁺

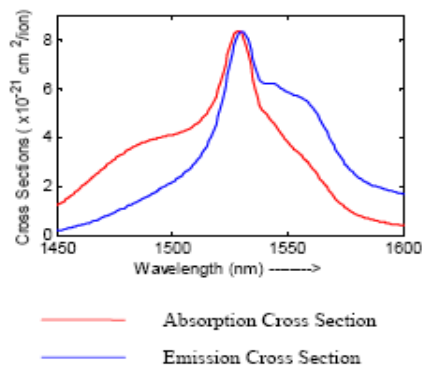

Fig. 3 shows the Absorption and Emission Cross-sections of EDFA (Source:11)

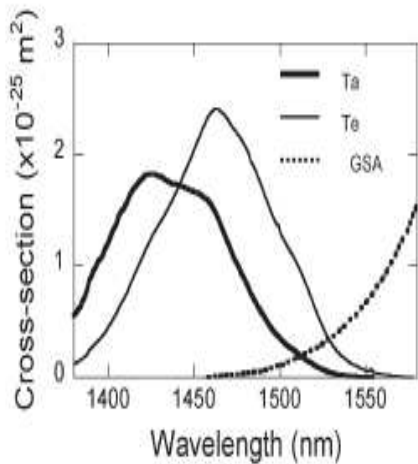

Fig. 4. The Cross sections of Tm^{3+} ions (Source:11)

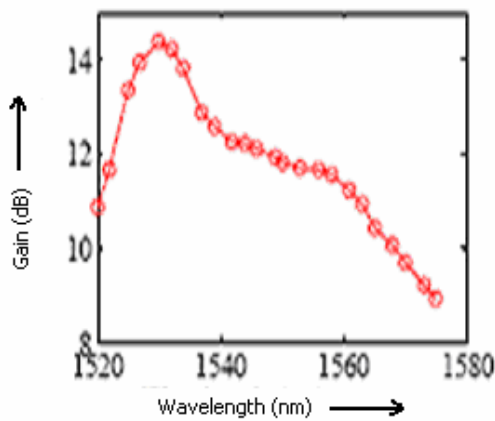

Fig. 5 Gain Spectrum of EDFA

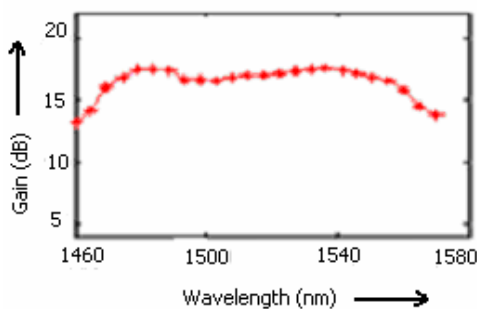

Fig. 6 Broadened Gain Spectrum of TDFA-EDFA Hybrid Amplifier

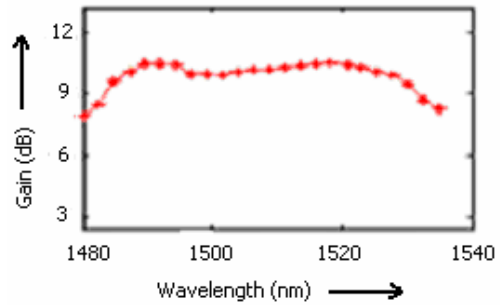

Fig. 7 Broadened Gain Spectrum of EDFA- TDFA Hybrid Amplifier

VI. CONCLUSION

It has found that calculated value of F ratio is very much different from the tabulated value, so the difference between parameters is considered as significant and we reject the null hypothesis. Here, we are able to conclude that for WDM systems, TDFA-EDFA hybrid fiber doped amplifier has higher gain and lower noise figure. So, this configuration gives better performance in WDM systems as compared with the EDFA-TDFA hybrid configuration.

ACKNOWLEDGMENT

The author would like to thanks Optical Communication Laboratory, PEC, U.o.T,Chandigarh.

REFERENCES

- [1] F. Roy, A. Sauze, P. Baniel and D. Bayart, "0.8- μ m-1.4 μ m Pumping For Gain Shifted TDFA with Power Conversion Efficiency Exceeding 50%," presented at the Optical Amplifiers Appl., Vancouver, B. C, Canada, Jul 2002(unpublished).
- [2] S.Aozasa, H. Masuda, Tadashi Sakamoto, Makoto Shimizu, "Gain Shifted TDFA Employing High Concentration Doping Technique with High Internal Power Conversion Efficiency Exceeding 70%," Electronics Letters. Vol. 38, No.8 PP.361-363, 2002.
- [3] R. M. Percival and J. R. Williams, "Highly Efficient 1.064 μ m Up conversion Pumped 1.47 μ m Thulium Doped Fluoride Fiber Amplifier," Electronics Lett. Vol. 30, no.20,pp. 1684-1685, Jun.1994.
- [4] S. Aozasa, H. Masuda, Makoto Shimizu, "Novel Gain Spectrum Control Method Employing Gain Clamping and Pump Power Adjustment in Thulium Doped Fiber Amplifier," Journal of Lightwave Tech., Vol.26, No. 10, May 2008.
- [5] Ishikawa, E. Nishihara, M.Sato, Y.Ohshima, C.Sugaya, Y.Kumasako, "Novel 1500nm-Band EDFA with Discrete Raman Amplifier," ECOC 2001, 27th European Conference, Vol.6, pp-48-49, 2001.
- [6] T.Komukai, T. Yamamoto, T. Sugawa and Y. Miyajima, "Upconversion Pumped Thulium Doped Fluoride Fiber Amplifier and Laser Operating at 1.47 μ m," Journal of Quantum Electronics, Vol. 31. pp. 1880-1889, Nov.1995.
- [7] Yamada M and Shimizu M, "Ultra-Wideband Amplification Technologies For Optical Fiber Amplifiers", NTT Technical Review, Vol 1, No. 3 June 2003.
- [8] T.Kasamatsu, Y.Yano and T. Ono, "Gain Shifted Dual Wavelength Pumped Thulium Doped Fluoride Fiber Amplifier for WDM Signals In The 1.48-1.51 μ m wavelength Region," Photonics Tech. Lett. , Vol. 12, No. 1, PP 31-33, 2001.
- [9] Ono H, Yamada M and Shimizu M, " S- Band Erbium Doped Fiber Amplifier with a Multistage Configuration- Design, Characteristics and Gain Tilt Compensation, Journal of Lightwave Tech., Vol.21, No. 10, Oct. 2003.
- [10] M.A. Khodasevich, S.A. Koval and G.V. Sinitsyn, "Simulation of the Ultimate Characteristics of Thulium Doped Fiber Amplifier", Optics and Spectroscopy Journal, 2009, Vol. 107, No. 3 Pp 414-419.

- [11] Tadashi Sakamoto, Shinichi Aozasa, Makoto Yamada and Makoto Shimizu, "Hybrid Fiber Amplifier Consisting Of Cascaded TDFA and EDFA for WDM Signals", Journal of Lightwave Tech. Vol. 24, No.6, June 2006.
- [12] Kaur Inderpreet, Gupta Neena, "Enhancing the Performance of WDM Systems By Using TFF in Hybrid Amplifiers", 2010 IEEE 2nd International Advance Computing Conference, Patiala, India, pp 106-109, Feb 2010.
- [13] Breiman, L (1995), "Better Subset Regression using the Nonnegative Garrote" Technometrics, 37, pp 373-384.
- [14] Breiman, L(1996), "Heuristics of Instability and Stabilization in Model Selection", Ann Statist., 24 pp 2350-2383.
- [15] Kaur Inderpreet, Gupta Neena, " Statistical Analysis of Components for wavelength Division Multiplexed System" International Conference on Optics and Photonics ICOP-2009, India.
- [16] S.Aozasa, H. Masuda, Tadashi Sakamoto, Makoto Shimizu, "Gain-shifted TDFA employing high concentration doping technique with high internal power conversion efficiency of 70%," Electron. Lett., vol. 38, no.8, pp 361-363, Apr. 2002.
- [17] Tadashi Sakamoto, Shinichi Aozasa, Makoto Shimizu, "Recent progress on S-band fiber amplifiers," presented at Euro Conf. Optical Communication (ECOC), Copenhagen, Denmark, 2002, paper 2.2.1.
- [18] HU Liangmei1, GAO Jun1,2, HE Kefeng1,2,XIE Zha, Image Fusion Using D-S Evidence Theory and ANOVA Method, Proceedings of the 2005 IEEE International Conference on Information Acquisition June 27 - July 3, 2005, Hong Kong and Macau.
- [19] Mottonen M., Pekka Belt, Janne Harkonen, Harri Haapasalo and Pekka Kess; "Manufacturing Process Capability and Specification Limits"; The Open Industrial and Manufacturing Engineering Journal; No. 1; pp. 29- 36; 2008.
- [20] Littell, Ramon C., Walter W. Stroup, and Rudolf J. Freund. 2002. SAS for Linear Models, 4th ed. Cary, NC: SAS Institute.
- [21] <http://www.tfrec.wsu.edu/ANOVA>.