

System Module for Student Idol

M. S. Roslina, and A. Noraziah

Abstract—Malaysia government had been trying hard in order to find the most efficient methods in learning. However, it is hard to actually access and evaluate students whom will then be called an excellent student. It is because in our realities student who excellent is only excel in academic. This evaluation becomes a problem because it not balances in our real life interm of to get an excellent student in whole area in their involvement of curriculum and co-curriculum. To overcome this scenario, we designed a module for Student Idol to evaluate student through three categories which are academic, co-curriculum and leadership. All the categories have their own merit point. Using this method, student will be evaluated more accurate compared to the previously. So, teacher can easily evaluate their student without having any emotion factor, relation factor and others. As conclusion this system module will helps the development of student evaluation more accurate and valid in Student Idol.

Keywords—Evaluation, curriculum, co-curriculum, idol, system module.

I. INTRODUCTION

EDUCATION is a crucial part in our life. Malaysia government had been trying hard in order to find the most efficient methods of learning in education industry. It is hard to actually access and evaluate students whom will then be called an excellent student, because in real life, most excellent students are students who only excels in academic. To handle such scenario, a program called Student Idol program to evaluate students through categories of academic, co-curriculum and leadership where students will collect merit points for every accomplishment. However, the program lack of consistency and facing difficulties in data handling as it involves data from hundreds of students.

Moreover, with the manual procedure, it will encourage occurrence of several problems that relates with it, like inconsistency of evaluation. Through the accumulation of many data, some might be slipped or even get unnoticed or wrongly calculated. Mistakes could occur as data are hard to maintain. Even with that, the error might not get detected by anyone. The evaluation result could become biased as it is almost like based on human perception.

Furthermore, humans are prone of doing mistakes. This situation could harm data integrity when the data also might

M. S Roslina is with the Faculty of Computer Systems & Software Engineering, University Malaysia Pahang, Lebuhraya Tun Razak, 26300 Kuantan, Pahang, Malaysia (phone: 609-549-2104; fax: 609-549-2144; e-mail: roslinams@ump.edu.my).

A. Noraziah, Dr. is with the Faculty of Computer Systems & Software Engineering, University Malaysia Pahang, Lebuhraya Tun Razak, 26300 Kuantan, Pahang, Malaysia (phone: 609-549-2121; fax: 609-549-2144; e-mail: noraziah@ump.edu.my).

be missing and damaged which is bad for later reference as well as for program performance. What's more, excessive workers are needed as it involves a lot of hard work in collecting, analyzing, calculate and sort through data for hundreds of students. To achieve the current high standard of what most people come to realize, the values one student should have, not just being excellent in the field of academic, but being a real person who have knowledge and skill and able to put it to practice whenever it suites. According to chapter five in 'Pelan Induk Pembangunan Pendidikan 2006-2010' by Malaysian's Ministry of Education [2], in order to achieve the goal of ensuring Malaysian's youth to be equipped with sufficient knowledge, a part of it suggested that the development of human capital should be focused on developing students' competency through enhancing curriculum, co-curriculum program, sports as well as consolidating discipline among students.

To overcome such situation, Student Evaluation System is build to computerize the current system and helps to evaluate in more consistent and precise way.

II. LITERATURE REVIEW

Since the beginning of the a best student program formation and implementation in certain school, it strongly holds on to the idea of producing excellent human person who are equivalent to a world class worker next to being a high quality citizen of Malaysia [1]. The program is carried out with a long term goal of realizing the school's goal of being exceptional thus setting a standard where others will look high at their perseverance and thus, become a role model to everyone.

In parallel with the government's goal, certain school has underlined several aspects including physical, human resource, academic, co-curriculum, personality and spirituality that must be achieved by all denizens [1]. The current system is implemented with the intention of encouraging students to further improve them particularly in guiding towards a point where it would benefit the students in future.

A. Student Information System (SIS) Prototype for School Administration

In a paper [3] written by three researchers from University Utara Malaysia for the development of SIS after being approached by school administrators of one school at Sintok, asking for their help in terms of expertise and financial aid to develop a system that could combine students' information, co-curriculum as well as details on their students' disciplinary

attitude. The real objective of building the prototype was to help the school in administering students' information in an efficient manner.

B. Characteristics of SIS

The information system is of a stand-alone type where it can only be used solely on a computer without having to connect to other computer as it is one of the requirements specified by the client. The system keeps record on students' details that includes personal information, co-curriculum activities and discipline. Meanwhile, the method of user interaction with the system is through filling out forms, accessing menus and buttons for direction. The users could search for students according to certain personal particular or co-curriculum activity through the search interface. The main menu interface of SIS is shown in the following Fig. 1.



Fig. 1 Interface of SIS main menu

The user could print out students' details information in a format introduced by the Ministry of Education. This function is used for preparing testimonial letter for graduated students. Other than that, the system allows its users to change their password, system configuration that includes add, edit or delete list of classes, clubs, sport houses or position. This function is shown in Fig. 2.



Fig. 2 Interface of SIS configuration

SIS offers decision support function through graphical statistical presentation. In this section, the overall statistic of students can be displayed according to race, religion, gender, 'Skim Pinjaman Buku Teks' (SPBT) qualification and disciplinary record. Moreover, the system offers a function for the user to save students' information as backup files.

C. Implementation of SIS

The system has been tested and implemented at the school. In order to access the level of users' satisfaction, a survey method had been done which focused on overall reaction on the system, level of learning capability in using the system and the system ability and achievement. The evaluation was done through applying a set of survey form containing 31 questions, given to six respondents after using SIS. The respondents consist of selected administrative teachers.

III. THE PROPOSED "IDOL" PROGRAM

The program was first proposed by the school's principal as a mean of evaluating students. The main idea is to evaluate through different aspects of accomplishment which includes academic achievement, school's activities involvement as well as leadership value. To promote a solution through rather a refine way, the principal set the evaluation calculation to a percentage of like 50% for academic, 30% for co-curriculum and 20% for leadership. The ratio would give an idea on how important the other aspects (co-curriculum and leadership) are, small but not to be forgotten. The process involves mainly the school's teacher, particularly, the class-teacher, as they are the one who are responsible to input information regarding matters involving their students' achievements.

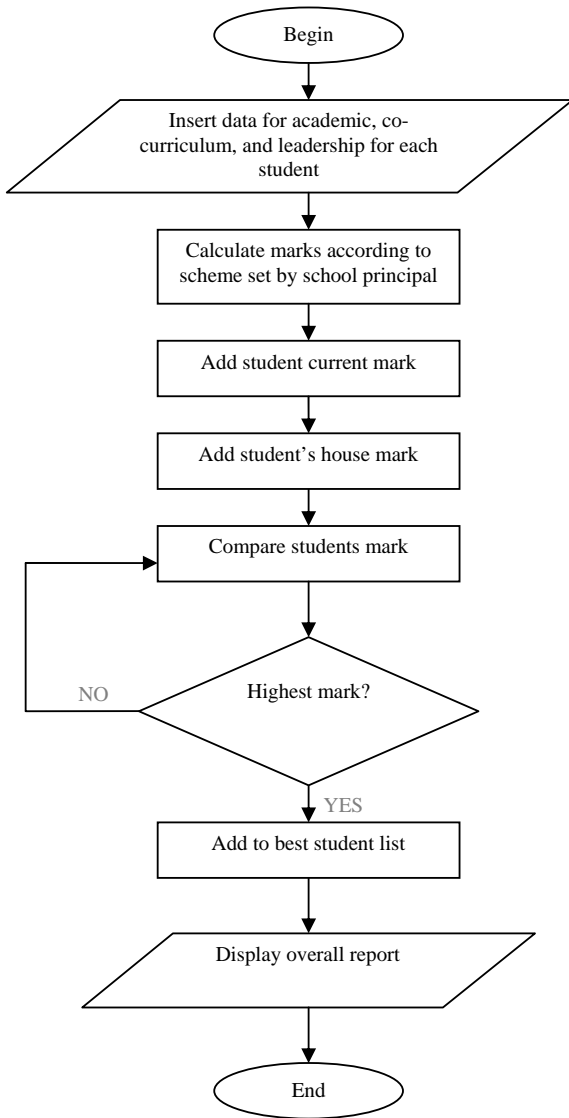

Fig. 3 System Flow

A. Software Design

This paper is concentrate on the evaluation system module and report module.

a) Student Evaluation Module

This module illustrated by the following Fig. 4 is used by staffs for student evaluation purpose. For evaluation, it contains three categories of academic, co-curriculum and leadership where staffs will fill in their students' achievements accordingly.



Fig. 4 Use Case Evaluate Student

The flow of this module is shown in following Fig. 5, where it starts when the staff selects a student from the list. A form appears where he or she could view student's profile. On the Student Evaluation page, there will an option for the staff to choose either to evaluate students through categories of academic, co-curriculum and leadership.

To evaluate category academic, the staff will click on "Academic". A form will appear where the staff will fill examination information like grades for each subject taken by the student (one by one). Student Idol system will save all information into the system database.

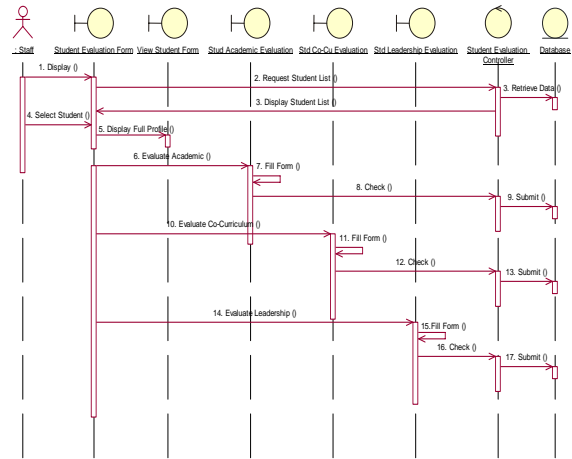

Fig. 5 Sequence Diagram for Basic Flow of Use Case Evaluate Student

To evaluate category co-curriculum, the staff will click on "Co-Curriculum". A form will appear where the staff will fill student's involvement into it. Student Idol system will save all information into the system database.

To evaluate category leadership, the staff will click on "Leadership". A form will appear where the staff will fill information regarding student's leadership achievement. Student Idol system will save all inserted information into the database.

b) Reporting Module

This module illustrated by the following Fig. 6 is accessed by the administrators. It could generate evaluation report that consists of top students for overall categories as well as for each category and current total marks for each sport houses. This module could generate certificates for final year student and for school events.



Fig. 6 Use Case Generate Report

The flow of this module is shown in following Fig. 7, where it starts after the administrator clicks “Evaluation Report” button at the menu selection. The report is generated by SES. Then, the administrator could view report by choosing one of the options, “Summary Report”, “Examination Report” and “Generate Certificates”.

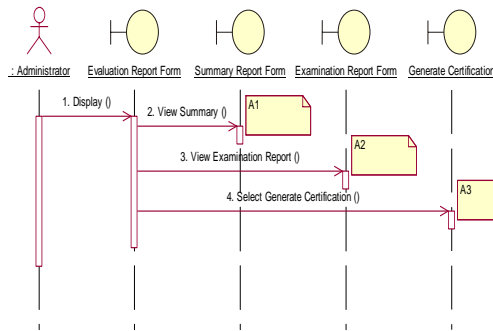

Fig. 7 Sequence Diagram for Basic Flow of Use Case Generate Report

Flows for summary report, examination report and generate certificates are listed as alternative flows shown in Fig. 8.

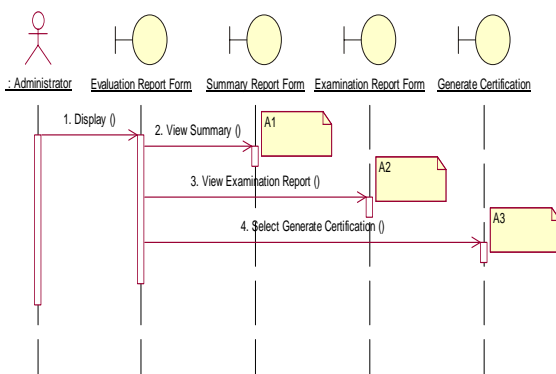

Fig. 8 Sequence Diagram for Basic Flow of Use Case Generate Report

IV. RESULT AND DISCUSSION

For future enhancement of Student Idol, it is suggested that Student Idol be implemented in schools all over Malaysia in

order to achieve the government’s goal of producing high quality human capital. Additionally, Student Idol process could be enhanced through implementing the use of MyKad reader particularly during student registration process as well as PDAs to add mobility throughout the course of evaluation.

V. CONCLUSION

The system evaluation module will be used in the development of Student Idol systems. The development is to cater the requirement of school in Malaysia to get the best student. It is used to more reliable calculation in hoping to overcome difficulties faced by the school which is consistency and data organization. Student Idol is build by using software engineering approach. The system development objective is to help evaluate students in a more consistent and precise way through using software engineering approach. Using this method, the teachers can easily evaluate the students and administrators can keep all the data in a much more advance and systematic manner.

ACKNOWLEDGEMENT

A very thankful to Sekolah Menengah Kebangsaan St. Anne’s Convent Principal at Kulim, Kedah due to give all information about how to evaluate the best student. Hopefully this system will make their school management more precise and consistent.

REFERENCES

- [1] Ahli Jawatankuasa Convent Idol, 2006, Kertas Kerja Pra Perancangan Sekolah Menengah Kebangsaan St. Anne’s Convent, Kulim, Kedah Darul Aman, Malaysia.
- [2] Malaysian’s Ministry of Education, Bab 5 – Membangunkan Modal Insan, Pelan Induk Pembangunan Pendidikan 2006-2010.
- [3] Fakhrol Anuar Aziz, Ezanee Mohamed Elias, Mohd Nizam Saad (2002), Prototaip Sistem Maklumat Pelajar Untuk Pengurusan Sekolah, Sekolah Teknologi Maklumat, Universiti Utara Malaysia.
- [4] Panagiotis Louridas (2005), Introduction to Software Engineering, Department of Management Science and Technology, Athens University of Economics and Business.
- [5] Ian Sommerville, Software Engineering, 7th Edition, Chapter 1.