

# The Hybrid Dimming Control System for Solar Charging Robot

A. Won-Yong Chae, B. Hyung-Nam Kim, C. Kyoung-Jun Lee, D. Hee-Je Kim

**Abstract**—The renewable energy has been attracting attention as a new alternative energy due to the problem of environmental pollution and resource depletion. In particular, daylighting and PV system are regarded as the solutions. In this paper, the hybrid dimming control system supplied by solar cell and daylighting system was designed. Daylighting system is main source and PV system is spare source. PV system operates the LED lamp which supports daylighting system because daylighting system is unstable due to the variation of irradiance. In addition, PV system has a role charging batteries. Battery charging has a benefit that PV system operate LED lamp in the bad weather. However, LED lamp always can't turn on that's why dimming control system was designed. In particular, the solar charging robot was designed to check the interior irradiance intensity. These systems and the application of the solar charging robot are expected to contribute developing alternative energy in the near future.

**Keywords**—Daylighting system, PV system, LED lamp, Sun tracking robot.

## I. INTRODUCTION

ENVIRONMENTAL pollution and resource depletion has become a serious problem. That's why the renewable energy has been attracting attention as the new alternative energy. The solar PV market has been growing spectacularly over the last years and is forecast confirm this trend in the coming year[1]. According to the interest about the solar cell has increased, the reduction of power generation costs and the efficient use of energy through the PV system have been suggested as the new problem. Daylighting is often considered the best source of light for good color rendering and closely matches openings that provide the dual function of admitting light into the indoor spaces and connecting the outside world to the inside of a building. Daylighting is recognized as an important and useful strategy in displacing the need for high grade energy used for interior lighting.[2]

In this paper, hybrid dimming control system supplied by solar cell and daylighting system was designed for application to the building. In addition, LED lamps which have semi-permanent life and high utilization are applied for secondary source of daylighting system. The PV system supplies the power to the batteries in the sunny day, and then batteries supply the power to the LED lamps. To integrate

A. B. Author is master course with the Interdisciplinary Program in Robotics, Pusan National University, Pusan, South Korea (e-mail: cwyzzang20@hanmail.net, khnlj@naver.com).

C. Author is doctor course with the Electronic and Electrical Engineering Department, Pusan National University, Pusan, South Korea (e-mail: netiz21c@hanmail.net).

D. Author is professor with the Electronic and Electrical Engineering Department, Pusan National University, Pusan, South Korea (corresponding author to provide phone: 082-051-510-3186; fax: 082-051-516-3889; e-mail: heeje@pusan.ac.kr).

daylight and electric light, automatic lighting control systems have been developed to fulfill the demand for energy savings and further environmental protection issues.[3] That's why the circuit for dimming control is designed. The DC-DC Converter, CdS sensor and MCU are used for dimming control. Dimming control system was suggested for supplying stable power.

The solar charging robot application will be expected to contribute the development of the alternative energy in the near future so we designed the solar charging robot and then we checked the circumstance of the building with the robot. We can confirm the circumstance of the building through this research.

## II. PV AND DAYLIGHTING SYSTEM

### A. PV system

The PV system supplies the power to the batteries. The PV system consists of the crystalline solar module, MPPT Converter and MPS. The crystalline solar module is made of the four solar cells which connect in 2series-2parallel. The total power is 800W. MPPT Converter produced Phocos company is used to supply the maximum power, and the MPS produced Phocos company is used to connect the batteries. The next figure 1 is the block diagram of the PV system.

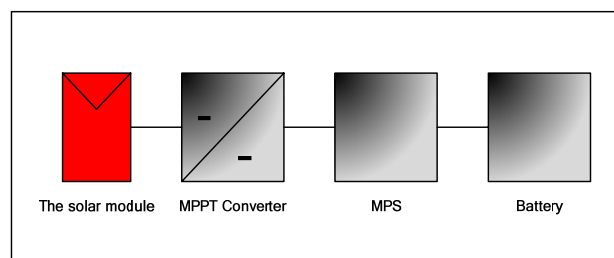

Fig 1 The block diagram of the PV system

Fig. 2 shows the installed PV system. The fixed format has benefits such as reasonable price, easy maintenance work and so forth, so we decided to set up the fixed format. The efficiency of the PV system is different by changing the irradiance. The irradiance is changed due to the angle and season. The fixed 35 degrees is the best angle regardless changing the season that's why this degree was decided. The figure (a) is the crystalline solar module installed. The figure (b) is the PCS system to charge the batteries. The PCS system consists of the MPPT Converter and the MPS.



(a) Crystalline solar module (b) PCS system

Fig. 2 PV system

B. Daylighting system

The Fig. 3 shows the daylighting system. That system was applied to the container box(2mX 3mX 2m). On top of the roof, there is a reflector which helps getting more irradiation. The daylighting system is just used for checking the interior dimming circumstance of the building.

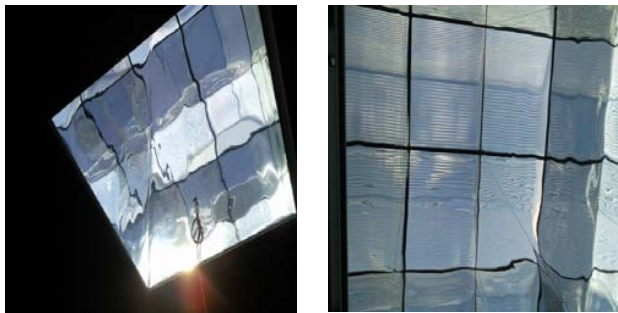

Fig. 3 The reflector of the daylighting system

III. DIMMING CONTROL SYSTEM

A. DC-DC Converter

The DC-DC Converter is designed to operate LED lamps. It's the boost converter in DCM which is Discontinuous Conduction Mode. The boost switches are turned on when the current through the corresponding boost rectifier is zero.[4] The boost converter in DCM operation can reduce the capacity and switching loss compared CCM which is Continuous Conduction Mode even though DCM has a limit of boost. Consequently, DCM Converter is designed without the problem of the boost. Next figure is typical topology of the boost converter. Table 1 is the parameter in the circuit, and Table 2 is the model of the devices. The value of the parameter is the value for making the boost converter in DCM.

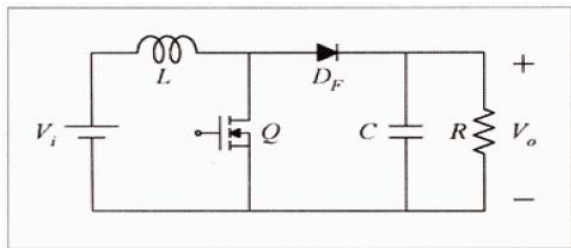

Fig. 4 DCM boost converter

TABLE I PARAMETER IN THE CIRCUIT

Parameter	Value	Parameter	Value
L	57[uH]	Vo	45[V]
C	500[uF]	fo	30[KHz]
Vi	24[V]	Io	1.1[A]

TABLE II MODEL OF THE DEVICE IN THE CIRCUIT

Device	Model	Device	Model
Mosfet	IRF740B	L	Changsung
Diode	40CTQ150	LED	Osram

The next equations are to obtain the power, load, frequency and inductor. Those are also equations for making the boost converter in DCM.

$$P = \frac{0.64TVi^2(Vo - Vi)}{2LVo} \tag{1}$$

$$Ro = \frac{V^2}{P} \tag{2}$$

The frequency is decided the resistance and capacitor in the control circuit. In this paper, control circuit is omitted. The frequency is 30 kHz. The boost converter in DCM doesn't need the high speed frequency that's why this frequency was decided.

$$fo = \frac{1.72}{R_T C_T} \tag{3}$$

$$L = \frac{0.64RoVi^2(Vo - Vi)}{2fVo^3} \tag{4}$$

Fig. 5 shows the waveform of the boost converter in DCM.

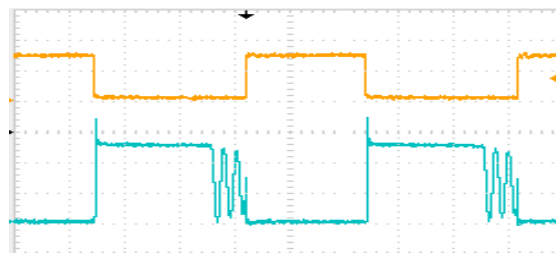

Fig. 5 The waveform of the DCM boost converter

The waveform located at the top is Vds, and the waveform located at the bottom is Vgs. The MOSFET is turned on when the current is zero. The DCM is confirmed through that waveform.

B. Dimming Control System

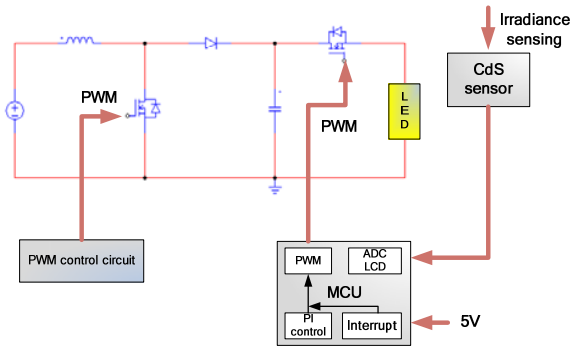

Fig. 6 The entire dimming control system

Fig. 6 shows the entire dimming control system. The boost converter in DCM was already explained. The power of the output will be boosted to the voltage with 45V when the PV system supplies the power to input. The PWM control circuit controls the switching of the left switch, and the MCU controls the switching of the right switch. In other words, both analog control and digital control are used to control the DC-DC converter. The left switch using analog control is used to control the output voltage, and the right switch using digital control is used to control the dimming of the LED. The PIC16F877A is used as the MCU. At first, the MCU receive the voltage value through the CdS sensor. At this time, the value is analog value. MCU need the digital value that's why ADC is used to convert to the digital value. LCD is used to see the value. The value compares with the reference value and then PWM signal generate for dimming control. The PI control is used to control more accurately. Fig. 7 shows the hand-made dimming control system in the Lab.

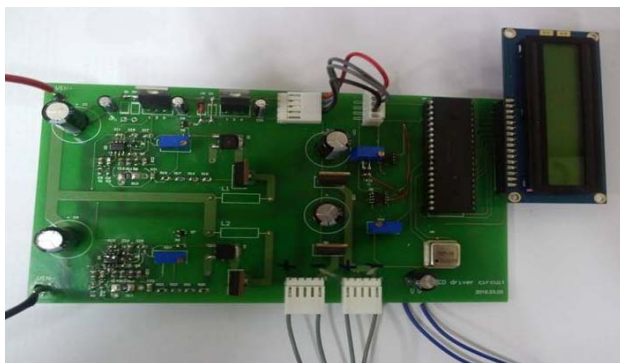

Fig. 7 Actual dimming control system

IV. SOLAR CHARGING ROBOT

A. Solar charging robot design

Solar charging robot was designed for checking irradiance circumstance. The robot can charge the batteries through the sunlight and also can find the place which is the highest irradiance intensity like sun tracker. The interior irradiance circumstance was checked due to moving the robot. The next figure 8 is the block diagram of the entire system.

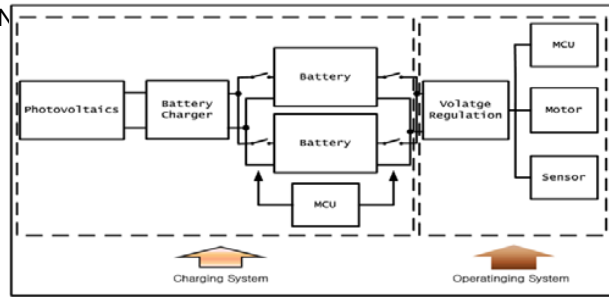

Fig. 8 The block diagram of the entire system

The entire system consists of charging part and operating motor part. The charging part is the system which charges rechargeable batteries. The operating motor part is the system which operates the motor. The first, the charging part will be explained. The Si solar cells are selected as the energy conversion device. Those are linked to series-parallel form which can supply enough power for operating robot. The charging circuit is designed for charging rechargeable battery. That circuit is the protection circuit for supplies the stable power that's why the maximum could be supplied. The rechargeable battery is the Li-ion battery. It has the benefits such as high speed charging, semi-permanent using, no pollution and long life. 4 Li-ion batteries are used as the power supply. Those consist of main power supply part and spare power supply part. The main power supply part operates the robot, and the spare power supply part charges the solar cells. In other words, dual battery charging system was designed. Each part changes the role through charging state. When charging is over, the role will be changed through the switching. The relay is used for switching. The light-aware system is the intelligent control system which can find the highest irradiance intensity place through the algorithm. The next figure 9 is the algorithm.

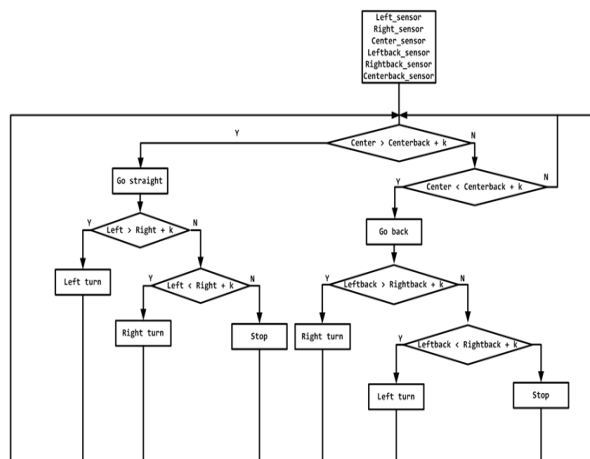

Fig. 9 The sun tracking algorithm

The CdS sensors were attached to 6 directions of the solar module. MCU using AVR respectively compares the data through algorithm, and then the robot moves where the place has lots of sunlight. Table 3 is the model of the devices.

TABLE III MODEL OF THE DEVICE

Model	device	Model	Device
Si solar cell	SH-1234	AVR	Atmega128
Battery	Li-ion	Motor	RA-35GM
CdS	GL-5537	Derive	BA-6208

Vol.4, No.12, 2016  
 development program for robotics support program supervised by the NIPA (National IT Industry Promotion Agency). (NIPA-2010-(C7000-1001-0009))

## REFERENCES

- [1] S.Silvestre, "Study of bypass diodes configuration on PV modules", *Applied Energy* 86(2009) 1632-1640
- [2] Danny H.W.Li, "Lighting and energy performance for an office using high frequency dimming controls", *Energy Conversion and Management* 47(2006) 1133-1145
- [3] A.-S.Choi, "Analysis of daylight responsive dimming system performance", *Building and Environment* 34 (1999) 231-243
- [4] Yung Taek Jang, "New Two-Inductor Boost Converter With Auxiliary Transformer," *IEEE Transactions on Power Electronics* Vol.19 No 1, January 2004

Fig. 10 shows the solar charging robot, and Fig. 11 is the result of the experiment. The sun tracking robot followed the highest irradiance intensity place.

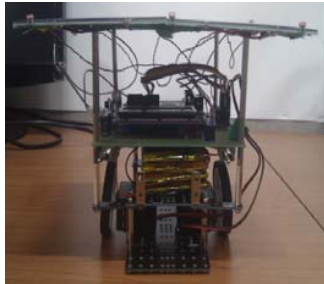

Fig. 10 The sun tracking robot



Fig. 11 The result of the experiment

As the result, the hybrid system supplied the stable power without separate electric, and the interior irradiance circumstance was stable by controlling irradiance. The dimming control was checked by the solar charging robot. The solar charging robot found the highest irradiance intensity place, and then the robot was charging the batteries without any problems. It just kept the sudden change which is the weather change due to external factors.

## V. CONCLUSION

In this paper, the hybrid system was designed to control dimming. The hybrid system consists of PV system and daylighting system. PV system supports the power to daylighting system. The hybrid system is renewable and clean energy as well as the energy conservation system. In dimming control system, boost converter in DCM, CdS sensors and MCU were applied. That system used PWM operation formula. Both analog control and digital control were applied for PWM operation. The role of analog PWM operation is used to supply stable power to LED, and digital PWM operation is used to control dimming. The result of the experiment was proved through the state of the solar charging robot. In the near future, the hybrid system and solar charging robot will be applied to a variety of applications.

## ACKNOWLEDGMENT

This research was supported by the MKE (The Ministry of Knowledge Economy), Korea, under the Human resource