

Dead-Reckoning Error Calibration using Ceiling Looking Vision Camera

Jae-Young Choi and Sung-Gaun Kim

Abstract—This paper suggests a calibration method to reduce errors occurring due to mobile robot sliding during location estimation using the Dead-reckoning. Due to sliding of the mobile robot caused between its wheels and the road surface while on free run, location estimation can be erroneous. Sliding especially occurs during cornering of mobile robot. Therefore, in order to reduce these frequent sliding errors in cornering, we calibrated the mobile robot's heading values using a vision camera and templates of the ceiling.

Keywords—Dead-reckoning, Localization, Odometry, Vision Camera

I. INTRODUCTION

THIS paper suggests a method to reduce the errors that occur during an indoor auto drive of a mobile robot using the Dead-reckoning method. The Dead-reckoning method uses gyro, encoder, and speedometer to calculate a mobile robot's location and direction by using only the robot's odometry.

The accuracy of the localization is essential in enhancing the reliability in many functions of the mobile robot including the Obstacle Avoidance, Path Planning or SLAM (Simultaneous localization and mapping). Many sensors are used in order to improve the accuracy of the localization. As to the location estimate, there is the method using the Heading value of the Odometry value of the encoder sensor and IMU sensor [1]. And there is the method using the vision sensor for the landmark cognition and detection of features [2].

With the presumption that the robot does not slide off and the size and rotation angle of its wheels are exactly known, the Dead-reckoning auto drive method is adequate enough to calculate the precise location of the robot. However, using the Dead-reckoning method, there are various potential causes for errors that would eventually accumulate and become a big one such as sensor errors, sliding of wheels during auto-runs, or modeling errors.

Proposed method suggests a way to reduce one of the potential errors with Dead-reckoning method, the error caused by mobile robot sliding during auto-runs.

Sliding of the robot occurs depending on the conditions of road course and they especially adds on the errors to dead-reckoning method.

Jae-Young Choi, Division of Mechanical and Automotive Engineering, Kongju National University, Republic of Korea, (e-mail: choijae88@kongju.ac.kr)

Sung-Gaun Kim*, Division of Mechanical and Automotive Engineering, Kongju National University, Republic of Korea, (e-mail: kimsng@kongju.ac.kr)

In effort to reduce the errors in cornering, we installed a vision camera facing the ceiling and used a Differential Skid-steering mobile robot so that the wheels on either side of the robot maintain same velocity but different directions so the wheels could rotate on spot. Before skid steer, we established a pattern saved from region-of-interest designated on the vision camera. From this established patterns, we can extract the angle of rotation as well as the exact heading value of the robot by comparing the videos taken before and after the turn. With this information, we can reduce the errors occurring from larger or smaller heading values of the robot resulting in sliding.

II. KINEMATIC MODEL

The differential skid-steering mobile robot used in the experiment for this paper is resembles the schematic drawing of Fig 1. The mobile robot has 4-Wheel Skid-Steering system which runs without any separate steering apparatus, but decides its course of direction by the sum of the wheels' power.

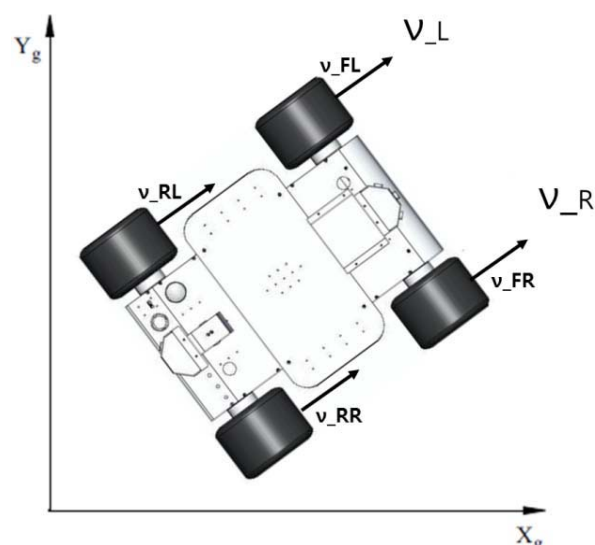

Fig. 1 Wheel velocities

In order to calculate the translational velocity and rotation velocity of a Differential Skid-steering mobile robot, the travel quantity of left and right side wheels have to be calculated.

There are two encoders on each of the sides, and travel quantities of wheels on each side are determined from the average mean of records from the two encoders.

$$\Phi_L = \frac{\Phi_{FL} + \Phi_{RL}}{2} \quad (1)$$

$$\Phi_R = \frac{\Phi_{FR} + \Phi_{RR}}{2} \quad (2)$$

Here, Φ_R and Φ_L represent the average mean of two encoders on right and left side wheels respectively. Using the value calculated from the equations above, we can now calculate the translational velocity (v) and the rotation velocity (ω) stands for the wheel's radius,

$$v = \frac{r(\Delta\Phi_R + \Delta\Phi_L)}{2t} \quad (3)$$

$$\omega = \frac{r(\Delta\Phi_R - \Delta\Phi_L)}{Dt} \quad (4)$$

D is the distance between a right-side wheel and a left-side wheel [3].

The odometry location estimate over the time is as follows

$$X_{k+1} = X_k + v_k \Delta T \cos \theta_k \quad (5)$$

$$Y_{k+1} = Y_k + v_k \Delta T \sin \theta_k \quad (6)$$

$$\theta_{k+1} = \theta_k + \omega_k \Delta T \quad (7)$$

III. ERROR CALIBRATION USING A VISION CAMERA

The mobile robot slides off its course and causes errors on Dead-reckoning method especially when cornering. Therefore reducing the errors occurring here can minimize the errors altogether, and for this we installed a vision camera facing the ceiling. From the video taken before the robot rotates at a corner we temporarily saved its ROI as a template and when the robot rotates with a desired heading value the rotation angle on the video at that moment is compared with the temporarily saved one; from this we can make the mobile robot rotate with a precise heading value.

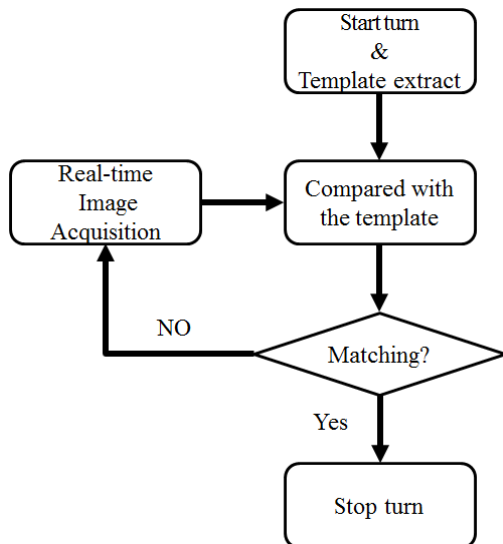

Fig. 2 Flow Chart Comparing the acquired images and Templates

Fig 3 shows a program that matches the templates using NI LabVIEW. If the templates are matched simultaneously, there might be some breakage of the video. Therefore, we used queue and made the first loop to obtain the real-time footage and a second loop to execute template matching. Like shown in Fig 4, the real-time video of the mobile robot on run can be simultaneously viewed with the angles from template matching program shown on the front panel indicator.

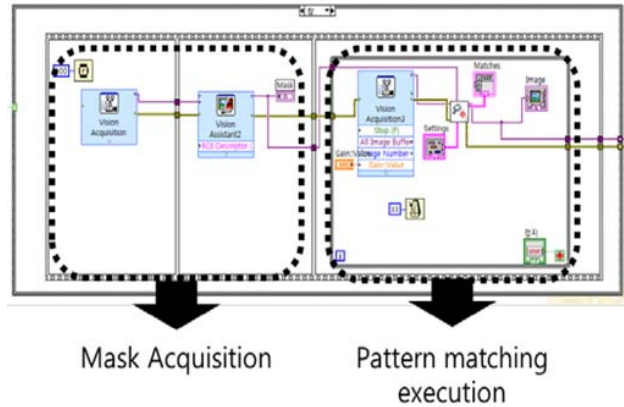

Fig. 3 Real-time image acquisition and Pattern matching

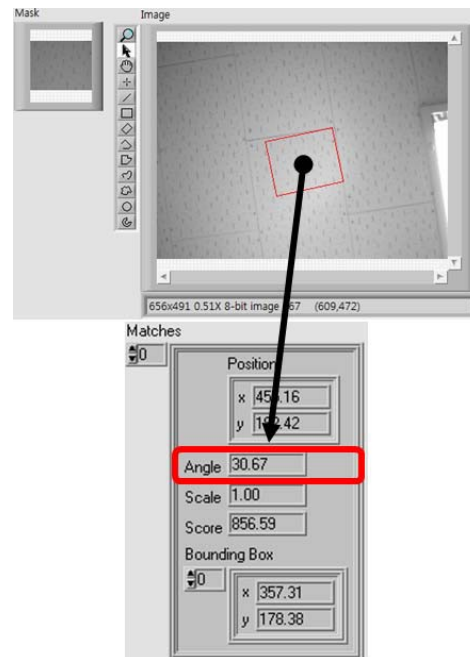

Fig. 4 angle measurement using LabVIEW

IV. EXPERIMENT CONDITION

For image processing in the experiment, we used the Basler A602F 8-bit Camera as shown in Fig 5. The mobile robot used has its platform composed of NI cRIO of unmanned solution as can be in Fig 6.



Fig. 5 8-bit, 60fps Vision Camera

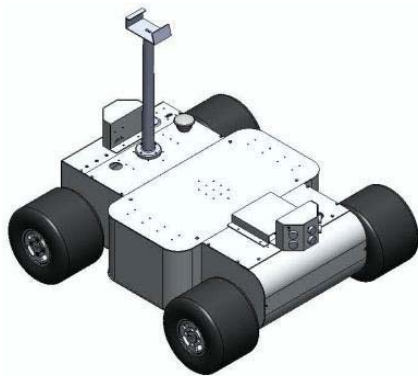

Fig. 6 4-Wheel Differential skid-steering Mobile Robot

LabVIEW and LabVIEW Vision Development Module from National Instrument Corporation were used for overall programming for this experiment.

The vision camera on the mobile robot was installed to face the ceiling and the entire experiment was done indoor on a rectangular running course.

V. EXPERIMENT AND DISCUSSION

We measured the errors in cornering using a 4-wheel Differential skid-steering mobile robot running on courses with 3000mm, 2000mm, 1500mm, and 1200mm distance before cornering. The experiment was repeated three times each for the control values obtained using only the encoder and the experiment values using the Dead-reckoning camera with a vision camera to calibrate cornering errors.

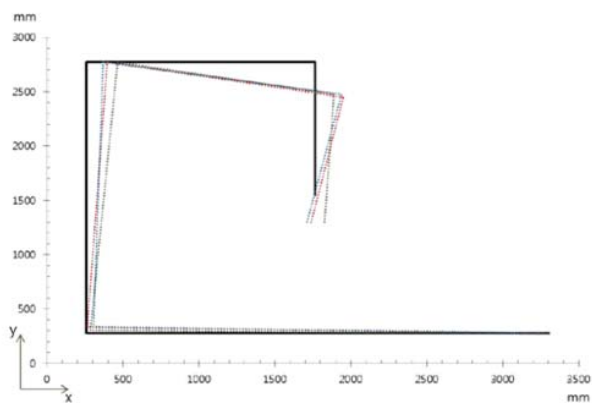

Fig. 7 Odometry information before calibration

In Fig 7, the data is shown for the location of mobile robot while on course measured using encoders. As can be seen, errors occurred as the mobile robot made a turn and the errors continuously accumulated.

TABLE I
COORDINATES OF MOBILE ROBOT FINAL DESTINATION USING ENCODERS

Repeat	X(mm)	Y(mm)
1	30	210
2	65	205
3	150	240
Average	81	218

Table I contains the coordinates of destinations using Dead-reckoning method with only encoders. Using the designated destination as a reference point, the data shows that there occurred a location error by 81mm on X-axis and 218mm on Y-axis in average.

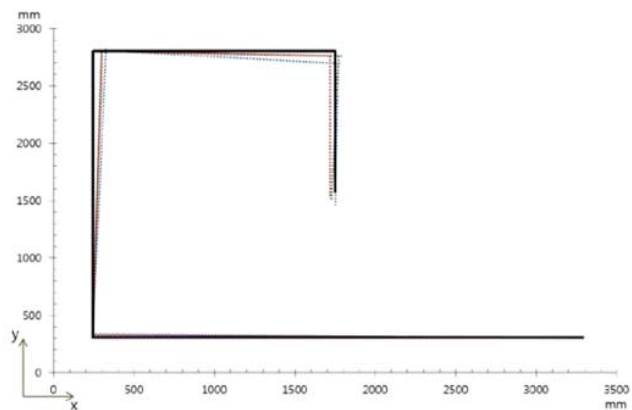

Fig. 8 Odometry information Calibration Using Vision Camera

Fig 8 shows the data of the mobile robot's actual odometry information after calibration using a vision camera

As can be seen in the Fig. 8, with calibration using a vision camera the values were relatively more accurate than using only encoders for Dead-reckoning method.

TABLE II
COORDINATES OF MOBILE ROBOT USING VISION CAMERA CALIBRATION

Repeat	X(mm)	Y(mm)
1	10	72
2	58	50
3	50	54
Average	39	58

Table II contains the coordinates of mobile robot using vision camera calibration on Dead-reckoning method. Using the designated destination as a reference point, the data shows that there occurred a location error by 39mm on X-axis and 58mm on Y-axis in average.

Fig. 6, Fig. 7 and I Tables, and II Tables are compared, it is shown that for the error correction system using the vision

camera, and the accuracy is considerably enhanced based on the destination by the X-axis 42mm and Y-axis 160mm.

VI. CONCLUSIONS

This paper proposed a method to reduce the errors and increase accuracy of Dead reckoning method by comparing the videos of the mobile robot before it corners and after it taken from a vision camera facing the ceiling.

From our experiment of location estimation of mobile robot on auto run done indoors, we confirmed that data using the vision camera calibration resulted in higher accuracy than using only encoders.

By vision camera calibration, we were able to obtain the exact heading values of mobile robot. However, due to core shift caused by different velocity between the wheels on both sides, some errors were detected. Also, a small error occurred on the straight course.

From now on, we will correct the sliding of straight course by yaw-axis in sensor. And we need decrease of error about motor's speed gap or disturbance by Feedback control. Also, to solve the problem that accumulates error continuously, we require introducing of based on possibility and position recognition system which utilize EKF, Particle Filter.

ACKNOWLEDGMENT

This work was supported by the research grant of the Kongju National University in 2012

REFERENCES

- [1] K.J Kim, N.Y Ko, D.J Seo, S. S Park, "Dead-Reckoning Error Correction Using Orientation Information", Korea Institute of Information Technology Spring Conference, pp. 238-243, 2007
- [2] S.Y Hwang, J.B Song "Monocular Vision and Odometry-Based SLAM Using Position and Orientation of Ceiling Lamps", *Journal of Institute of Control, Robotics and Systems*, pp.164-170, 2011
- [3] Krzysztof Kozłowski, Dariusz Pazderski, "Modeling And Control Of A 4-Wheel Skid-Steering Mobile Robot", *Int. J. Appl. Math. Comput. Sci.*, 2004, Vol. 14, No. 4, 477-496
- [4] J.G Kang, W.S Choi, S.Y An, and S.Y Oh, "Improving Accuracy of SLAM using Online Estimation of Odometry Error", Proceedings of KIIS Fall Conference, pp267-270, 2009 Vol. 19, No.