

Temperature Sensor IC Design for Intracranial Monitoring Device

Wai Pan Chan and Minkyu Je

Abstract—A precision CMOS chopping amplifier is adopted in this work to improve a CMOS temperature sensor high sensitive enough for intracranial temperature monitoring. An amplified temperature sensitivity of $18.8 \pm 3 \times 0.2$ mV/°C is attained over the temperature range from 20 °C to 80 °C from a given 10 samples of the same wafer. The analog frontend design outputs the temperature dependent and the temperature independent signals which can be directly interfaced to a 10 bit ADC to accomplish an accurate temperature instrumentation system.

Keywords—Chopping; analog frontend; CMOS temperature sensor; traumatic brain injury (TBI); intracranial temperature monitoring.

I. INTRODUCTION

TRAUMATIC brain injury (TBI) is a severe damage to a brain by an external force, and it can cause the intracranial temperature to rise up to few degrees in Celsius over the body temperature [1]. However, it is still not clear whether the raised intracranial temperature is an adaptive response to the trauma or a harmful outcome to the brain tissue [2]. Therefore, in addition to monitoring the level of the brain pressure and the dissolved oxygen, it is a common practice in the hospital to equip with continuous intracranial temperature monitoring systems such that the physician can acquire the TBI patient's brain temperature at any time. Failing in accessing the update and an accurate intracranial temperature can have an adverse effect in managing the patient health

Temperature sensing applications are heavily employed in academic, commercial, industrial, and medical community. For high precision temperature sensor, the sensor choice is usually a platinum based resistance temperature detector (RTD). Many commercial RTDs can measure ambient temperature in a precision of less than 0.1 °C. Nonetheless, the material is very expensive, and it requires an external instrumentation system to be set up.

An alternative choice to a RTD is a parasitic vertical bipolar transistor in standard CMOS platform. The device is very well modeled in commercial foundries, so a lot of designers have been using this device for creating temperature sensing applications. Ideally speaking, it is more favorable and practical to develop a temperature sensor in CMOS technology as the sensor can be made more robust and intelligent by designing an application specific integrated circuit (ASIC) on the same substrate. We discussed elsewhere the specific requirements on the temperature sensors and the various system architectures to interface the sensor for intracranial applications [3].

Wai Pan Chan is with the Institute of Microelectronics, A*STAR (Agency for Science, Technology, & Research), Singapore 117685 (phone: +65-6770-5493; fax: +65-6774-5754; e-mail: chanwp@ime.a-star.edu.sg).

Minkyu Je is with the Institute of Microelectronics, A*STAR (Agency for Science, Technology, & Research), Singapore 117685 (e-mail: jemk@ime.a-star.edu.sg).

In this work, we will illustrate the application of chopping stabilization to realize a high sensitive temperature sensor for intracranial temperature monitoring, which requires a 0.1 °C inaccuracy over 10 °C temperature sensing range. The goal of this work is to increase the temperature sensitivity of the sensor precisely for interfacing with a 10 bit A to D converter.

II. CONVENTIONAL CMOS TEMPERATURE SENSORS: PRINCIPLE AND PRACTICE

Shown in Fig. 1 is a reference design in a typical temperature sensor instrumentation system.

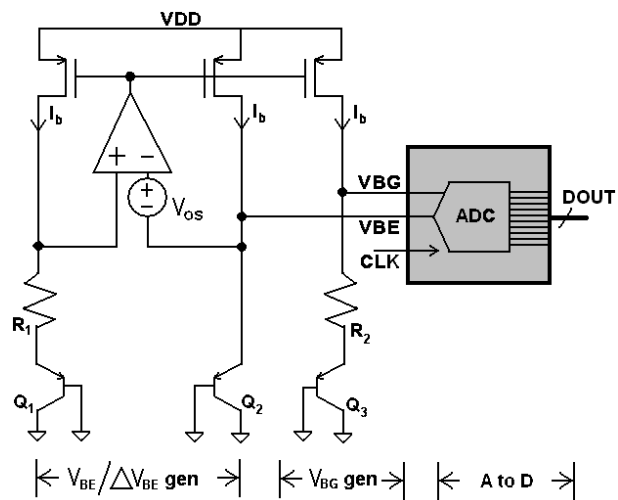

Fig. 1 Temperature sensor instrumentation system

Fig. 1 is made up of 3 cores: a $V_{BE}/\Delta V_{BE}$ generator, a bandgap reference (V_{BG}) generator, and an A to D data converter. The bias current I_b is defined in the $V_{BE}/\Delta V_{BE}$ generator, which consists of the two parasitic vertical bipolar transistors Q_1 and Q_2 using the same value of current bias. Assuming that the offset voltage V_{os} of the operational transconductor (OTA) is negligible, the expression of I_b can be approximated by (1).

$$I_b = \frac{V_{BE2} - V_{BE1}}{R_1} \quad (1)$$

Equation (1) holds true when the OTA is biased in high gain operation such that the non-inverting input and the inverting input are in virtual short. In other words, the base emitter voltage of Q_2 will be equal to the base emitter voltage of Q_1 plus the ohmic voltage drop across the resistor R_1 .

Equation (1) is an approximation because the forward current gain β_F of the bipolar transistors is assumed negligible, so the collector current of the bipolar transistors can be assumed to be equal to the bias current I_b .

Consequently, the base-emitter voltage of the bipolar transistor can be represented by (2).

$$V_{BE} = V_T \ln \left(\frac{I_b}{I_s} \right) \quad (2)$$

where $V_T (= kT/q)$ is the thermal voltage and I_s is the saturation current of the bipolar transistors. It is known that the saturation current has a strong dependency to temperature, so the base emitter voltage is non-linear dependent to temperature. To a 1st order approximation, the temperature sensitivity of the base-emitter voltage is equal to $-2 \text{ mV}^\circ\text{C}$, which is a complementary to absolute temperature (CTAT). Therefore, the base-emitter voltage can be taken as a temperature input signal, which can go directly for the A to D conversion as shown in Fig. 1.

Substituting (2) back into (1), I_b can be re-expressed as (3).

$$I_b = \frac{V_T}{R_1} \ln(n) \quad (3)$$

where n is the ratio of the emitter area between Q_1 and Q_2 . Equation (3) indicates that I_b is proportional to the thermal voltage V_T , and it is commonly referred as a proportional to absolute temperature (PTAT) current source.

In the bandgap reference generator as shown in Fig. 1, the PTAT current source I_b will create a voltage across the resistor R_2 . The ohmic voltage drop across R_2 is PTAT. On the other hand, the base emitter voltage of Q_3 is CTAT. Therefore, when the temperature sensitivity of the PTAT voltage and the CTAT voltage are the same, the sum of these two voltages will be temperature independent, which is commonly referred as a bandgap reference voltage. From Fig. 1, the bandgap reference voltage can be expressed as (4):

$$V_{BG} = V_{BE3} + \frac{R_2}{R_1} V_T \ln(n) \quad (4)$$

With reference to the temperature instrumentation system as shown in Fig. 1, the base emitter voltage and the bandgap reference voltage are connected directly to the input channel and the reference channel of the ADC respectively. For a 10-bit resolution ADC with 1.8 Volt input range, the least significant bit (LSB) is 1.76 mV. For a temperature precision to be within 0.1°C , the required temperature sensitivity has to be larger than $17.6 \text{ mV}^\circ\text{C}$. Obviously, the signal V_{BE} has to be amplified for the given 10 bit ADC to produce the digital output with the required resolution. We will revise the schematic design in the next Section to accommodate the required resolution.

The expression of the bandgap voltage in (4) does not take into account of the DC offset, V_{os} , of the amplifier. If the offset is not negligible, the expression of the bandgap voltage is represented by (5).

$$V_{BG} = V_{BE3} + \frac{R_2}{R_1} V_T \ln(n) + V_{os} \frac{R_2}{R_1} \quad (5)$$

Equation (5) indicates that the offset voltage of the OTA will be amplified by the resistor ratio of R_2 to R_1 . For our design, $R_2/R_1 = 11$, so the offset voltage will be amplified by 11 times which contribute to the typical mismatch of the bandgap reference voltage. The amplified offset voltage will inevitably degrade the inaccuracy of the measurement. In the next Section, we will see how chopper stabilization technique together with a resistor trimming network can minimize the effect of the OTA' offset on the temperature inaccuracy.

Last but not least, the inaccuracy of the base-emitter voltage or the bandgap voltage due to the process mismatch was well documented [4], [5]. To sum up, other than the offset due to the OTA, the temperature offset error is depended on the process spread of the saturation current of the vertical bipolar transistors, the limited value of the forward current gain of the bipolar transistors, the current mirror mismatch, and the mismatch of the passive resistors R_1 and R_2 . All these mismatches should be minimized and trimmed such that the design can be applicable for the typical temperature measurement range. In the scope of this work, the intended application is restricted to 10°C , so the use of chopper stabilization technique, together with a digital trimming on the resistance, are suffice to achieve the inaccuracy of 0.1°C .

III. CMOS CHOPPER STABILIZED TEMPERATURE SENSOR INSTRUMENTATION SYSTEM

A. $V_{BE}/\Delta V_{BE}$ generation based on chopper stabilization

The concept of chopper stabilization amplifier was well discussed and analyzed in [6], and it is briefly summarized here. Shown in Fig. 2 illustrates a chopper system where the input signal v_{in} is first up-converted to the chopping frequency f_{chop} before going to the amplifier A1. The amplifier has a DC offset v_{os} . After amplification, the amplified signal $A*v_{in}$ will undergo demodulation such that the ac-amplified signal is moved back to the baseband. On the other hand, the amplified offset $A*v_{os}$ will be up-converted to the chopping frequency f_{chop} . Therefore, the output of the chopping amplifier is a DC offset-free amplified baseband signal superimposed of an ac-amplified offset situated at the chopping frequency f_{chop} . Nonetheless, the output of the chopping amplifier has to be low pass filtered so as to eliminate the ac modulated offset.

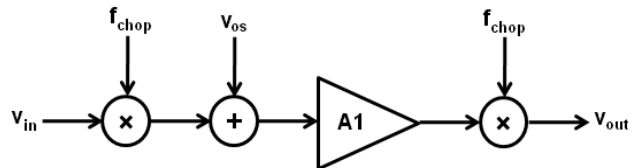

Fig. 2 Principle of Chopper Stabilization

Recall from Section II that the generation of the PTAT current sources is processed by the OTA as used in the $V_{BE}/\Delta V_{BE}$ generator. Unfortunately, the DC offset found in a typical CMOS OTA can go to $\pm 10 \text{ mV}$ in 3σ variations. This random offset will be subsequently amplified by a factor of R_2/R_1 as depicted in (5). As a result, there will be an amplified offset added into the bandgap reference voltage, and that offset will produce inaccurate temperature measurements. One improvement made in this work is illustrated in Fig. 3

which highlights the $V_{BE}/\Delta V_{BE}$ generator only. The OTA is replaced by the chopping amplifier.

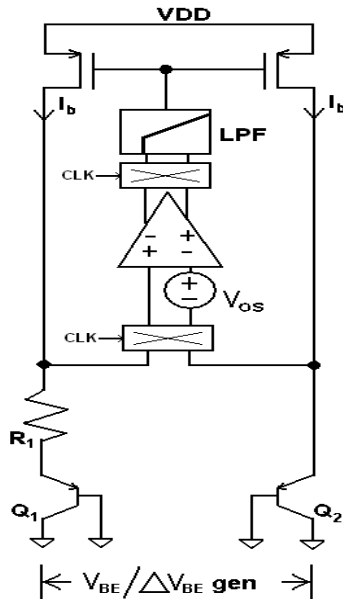

Fig. 3 $V_{BE}/\Delta V_{BE}$ generation employing a chopping amplifier

Shown in Fig. 3 is an improved version of the $V_{BE}/\Delta V_{BE}$ generator which employs chopper stabilization. The amplifier offset V_{os} is modulated once; this offset will be amplified and modulated to the chopping frequency, but this frequency modulated offset will be eliminated by the low pass filter (LPF). On the other hand, the inputs of the amplifier (i.e., the base emitter voltage of the parasitic vertical pnp transistors Q_1 and Q_2) are modulated twice, so they will be amplified at ac under the closed loop configuration and demodulated down to DC. Consequently, the voltage bias to the PTAT current sources is offset free, which is the key to achieve an accurate bandgap voltage and the temperature sensing signal V_{BE} .

B. V_{BE} tuning

To achieve the temperature output with an inaccuracy of ± 0.1 °C, other sources of offset has to be compensated. For instance, the current mismatch on the PTAT current source, the resistor mismatch between R_1 and R_2 , and the finite value of the forward current gain of the parasitic vertical pnp transistors all contributed to the mismatch on the temperature acquisition system. To ensure high precision, a one point calibration of the base emitter voltage of the pnp transistor Q_3 at room temperature is done via a digital trimming. The trimming can be done by trimming the emitter area, the PTAT current source, and the resistance. Under normal consideration of the design of the trimming network is to trade off the use of the chip area with the resolution of the trimming. In our design, resistance trimming is employed, and it is sketched in Fig. 4. Note that there are 32 switches connecting to 32 identical resistors in parallel. The control of the switches is done via a 5-to-32 decoder. The decoder generates only one active output high whereas all the other outputs are active low. There decoder outputs are connected to all the switches individually so that only one of the switches can be turned on.

In this way, 32 different values of resistance can be generated, and the equivalent base emitter voltage can be adjusted accordingly.

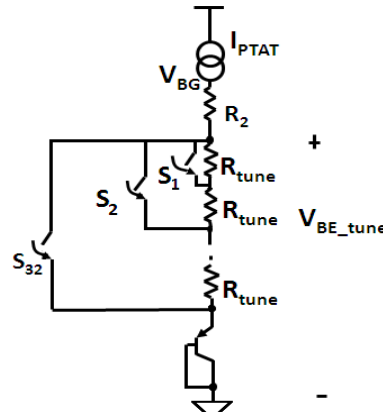

Fig. 4 V_{BE} voltage trimming

C. V_{BE} amplification

To achieve the temperature output with an inaccuracy of ± 0.1 °C, the resolution of the ADC should be 0.1 °C/LSB or lower. For a 10-bit ADC which does the AD conversion for a given bandgap reference voltage, the temperature signal V_{BE} has to be amplified in order to achieve the required resolution. In the silicon implementation, the temperature sensitivity of the trimmed V_{BE} signal is amplified by 10 times to achieve the required temperature resolution. The design is sketched in Fig. 5.

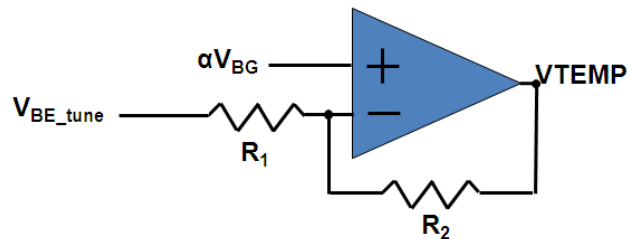

Fig. 5 V_{BE} amplification scheme

Note in Fig. 5 that the αV_{BG} is a bandgap reference voltage with the scale factor α . The expression of the signal V_{TEMP} can be represented by (6).

$$V_{TEMP} = \alpha V_{BG} - V_{BE} \left(\frac{R_2}{R_1} \right) \quad (6)$$

Since the closed loop gain, which is equal to $\frac{R_2}{R_1}$, is not small, a chopper stabilized amplifier is a preferred choice for achieving the required closed loop gain in the presence of any DC offset of the amplifier.

IV. SILICON MEASUREMENT RESULTS

The analog frontend CMOS chopper stabilized temperature sensor instrumentation system was realized in a $0.18\mu\text{m}$ 1P6M CMOS process, and it is packaged in a DIP28 for evaluation purpose. The die photo is shown in Fig. 6.

The core circuit has a dimension of 0.3mm x 0.9mm. The chip consumes less than 200 μ A current consumption under typical condition.

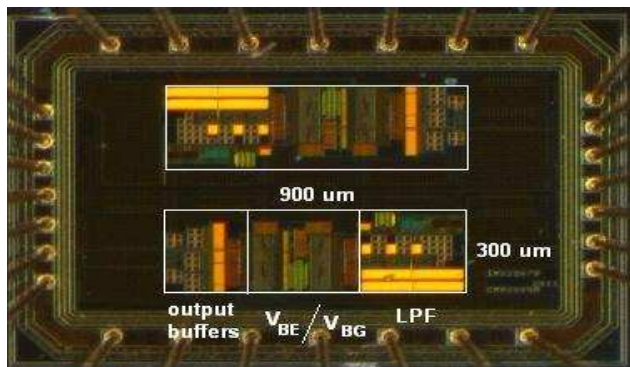

Fig. 6 Chip microphotograph

The experimental setup consists of a custom designed printed circuit board to interface the chip. The board provides test points to the bandgap voltage (VBG) and the amplified base emitter voltage signal (VTEMP). Besides, there is an on board crystal oscillator which provides a chopping frequency of 125 kHz. The board was placed inside an oven whose temperature can be adjusted through the GPIB interface. The output signals were captured by the external multimeters, which can send the data to a laptop through the same GPIB interface. Ten chips on the same wafer were evaluated, and the results are presented in the following.

Fig. 7 shows the measured bandgap reference voltage versus temperature. Although the intended temperature sensing range is specified to 10 $^{\circ}$ C, the chip can work well in the temperature range from 20 $^{\circ}$ C to 80 $^{\circ}$ C. In particular, the bandgap voltage mismatch is within 20 mV over the 10 chips. This amount of offset can be attributed to the offset associated with the output voltage buffer for probing the bandgap voltage. The temperature instability of this bandgap reference design is below 45 ppm.

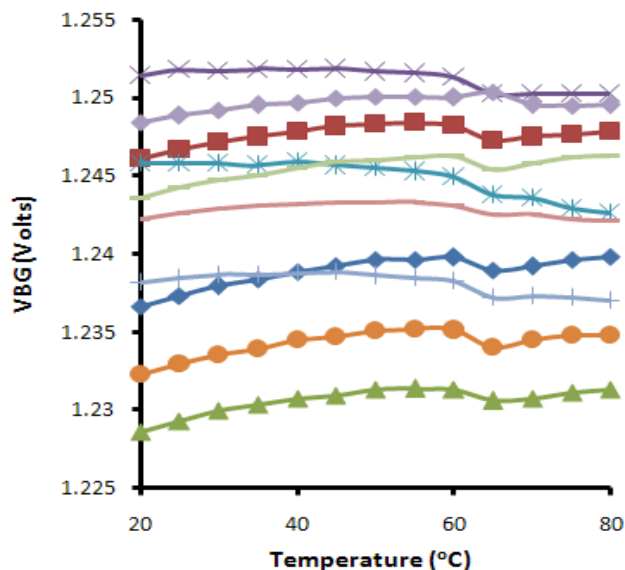

Fig. 7 Measured bandgap voltage (V_{BG}) vs temperature ($^{\circ}$ C)

Fig. 8 shows the variation of the measured temperature sensitivity over the 10 chips. The mean temperature sensitivity is found to be 18.8 mV/ $^{\circ}$ C with a standard deviation of 0.24 mV/ $^{\circ}$ C. Thus, the fabricated analog frontend design is able to achieve a temperature signal with a resolution of 0.1 $^{\circ}$ C/LSB for the 10-bit ADC. The temperature error due to the mismatched sensitivity is under 1.3%, which can be further reduced by the resistor trimming network.

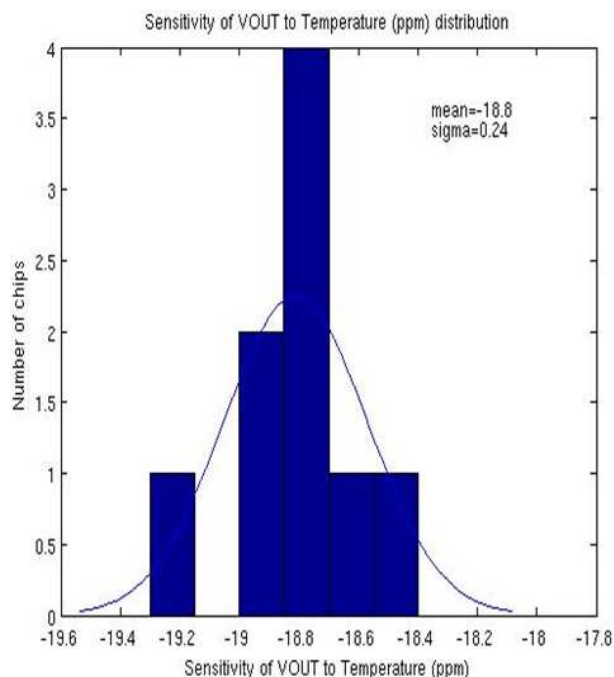

Fig. 8 Variation of temperature sensitivity over the 10 samples

The performance summary of the chopper stabilized temperature sensor analog frontend is tabulated in TABLE I.

TABLE II
PERFORMANCE SUMMARY

Process	0.18 μ m 1P6M CMOS
Number of samples	10
Supply voltage	3.3 Volts
Current consumption	200 μ A
Chopping frequency	125 kHz
Temperature range	20 $^{\circ}$ C to 80 $^{\circ}$ C
Bandgap temperature instability	< 45 ppm
Temperature sensor sensitivity	18.8 mV/ $^{\circ}$ C

V. CONCLUSION

A CMOS temperature sensor analog frontend utilizing chopper stabilization has been presented in this work. A high precision bandgap voltage is realized by the use of chopping to eliminate the DC offset, if any, from the amplifier used for the PTAT generation.

Further offsets due to the process mismatch are suppressed by a 5-bit resistor trimming network.

On the other hand, an amplified temperature sensitivity of the base-emitter voltage is achieved by amplifying the base emitter voltage such that the amplified signal can accomplish a resolution of 0.1 °C/LSB for the given 10 bit ADC.

ACKNOWLEDGMENT

The work was supported by the Science and Engineering Research Council of A*STAR (Agency for Science, Technology and Research), Singapore, under the grant number: 102 148 0002.

REFERENCES

- [1] C.S. Rumana, S.P. Gopinath, M. Uzura, A.B. Valadka, and C.S. Robertson, "Brain temperature exceeds systemic temperature in head-injured patients," *Crit Care Med.*, vol. 26, 1998, pp.562-567.
- [2] C. Childs, "The Role of Temperature in the Damaged Brain," *Raised Human Brain Temperature Good or Bad After Traumatic Brain Injury? Symposium and Workshop*, The University of Manchester, 2008.
- [3] W.P. Chan, and Minkyu Je, "A Review of CMOS Multimodal Neuromonitoring Sensors and Systems," *Integrated Circuits (ISIC) 2011*, pp. 416-419.
- [4] M.A.P. Pertijs, K.A.A. Makinwa, and J.J. Huijsing, "A CMOS Smart Temperature Sensor With a 3σ Inaccuracy of $\pm 0.1^\circ\text{C}$ From -55°C to 125°C ," *Solid-State Circuits Journal of.*, vol. 40, 2005, pp. 2805-2814.
- [5] M.A.P. Pertijs, and J.J. Huijsing, *Precision Temperature Sensors in CMOS Technology*, Springer, 2006.
- [6] C.C. Enz, E.A. Vittoz, and F. Krummenacher, "A CMOS Chopping Amplifier," *Solid-State Circuits, IEEE Journal of*, vol. 22, pp. 335-342, 1987.