

An Intelligent System for Knee and Ankle Rehabilitation

Dimitar Karastoyanov and Vladimir Monov

Abstract—The paper is concerned with the state examination as well as the problems during the post surgical (orthopedic) rehabilitation of the knee and ankle joint. An observation of the current appliances for passive rehabilitation devices is presented. The major necessary and basic features of the intelligent rehabilitation devices are considered. An approach for a new intelligent appliance is suggested. The main advantages of the device are: both active as well as passive rehabilitation of the patient based on the human - patient reactions and a real time feedback. The basic components: controller; electrical motor; encoder, force – torque sensor are discussed in details. The main modes of operation of the device are considered.

Keywords—Ankle, knee, rehabilitation, computer control.

I. INTRODUCTION

THERE is an increasing trend in using robots for medical purposes. One specific area is the rehabilitation. The percentage of persons suffering from muscular weakness of the lower limb can oscillate between 0.05% and 1% of the total European population; during 2006 by the statistics it is reported in Bulgaria have been done 59700 manipulations of the lower extremities (0.7% of the population). There are some continuous passive motion commercial (CPM) machines used for rehabilitation purposes. However, these machines have limited use because of their insufficient motion freedom. In addition, these types of machines are not actively controlled; they have not feedback and therefore cannot accommodate complicated exercises required during rehabilitation.

With this study we proposed a new intelligent mechatronic system which can accomplish active and passive knee and ankle rehabilitation based on feedback force control. Here an intelligent computer control structure with four degree of freedom mechanical system is proposed.

II. ACTUALITY OF THE PROBLEM

During the past 3 decades, continuous passive motion (CPM) devices have become a generally accepted part of post surgical treatment to promote healing and regeneration of joint cartilage. CPM machines for rehabilitation in the clinic or home are used post operatively to prevent joint stiffness after Total Knee Replacement, ACL repair, Femur Fractures, closed manipulation of the knee or shoulder. In 1970, Robert B.

V. Monov is with the Institute of Information and Communication Technologies, Bulgarian Academy of Sciences, 1113 Sofia, Bulgaria (phone: +359 2 979 2474; fax: +359 2 870 7273; e-mail: vmonov@iit.bas.bg).

D. Karastoyanov is with the Institute of Information and Communication Technologies, Bulgarian Academy of Sciences, 1113 Sofia, Bulgaria (e-mail: dkarast@iinf.bas.bg).

Salter, MD, PhD, a Toronto orthopedic surgeon, together with a succession of research fellows, first investigated the biological effects of CPM on healing and regeneration of articular tissues in rabbits [1]. Later, Salter and his colleagues began applying this basic research to human patients. They found that nine selected patients "have been relatively free of pain, have maintained the increased motion gained at operation, and have accepted the application of CPM well"

As described by O'Driscoll and Giori, Salter's basic premise is that "because immobilization is obviously unhealthy for joints, and if intermittent movement is healthier for both normal and injured joints, then perhaps continuous motion would be even better." However, because patients could not be expected to move their injured joints continuously for hours at a time, the movement would, of necessity, be passive. "He also believed that CPM would have an added advantage, namely that if the movement was reasonably slow, it should be possible to apply it immediately after injury or operation without causing the patient undue pain [2].

According to Hammesfahr and Serafino, CPM "is one of the primary methods for decreasing the deleterious effects of immobilization and can deliver orthopedic, neurological, and even circulatory benefits to the patient. Immobilization, in turn, can create deleterious sequelae of physiological and functional impairments [3].

Through the years, CPM devices have been created for most of the major joints of the upper and lower extremities, but they appear to be most frequently prescribed for post surgical use in injuries of the knee or shoulder. CPM is generally provided through devices mechanically designed to bend and flex joints at a given rate for several hours

III. CONTINUOUS PASSIVE MOTION DEVICES

Motion and stress are important for the maintenance of normal connective tissue and the healing of injured connective tissue. Motion enhances blood flow and decreases pain. Passive motion involves movement of a joint without active contraction of muscle groups. It is used to maintain range of motion (ROM) and flexibility in joints in the early postoperative and rehabilitative period after surgery or injury when active movement might disrupt the repair process or is too painful to perform. Continuous passive motion is a rehabilitation technique that involves introduction of progressive passive range of motion (PROM) to an extremity through an externally applied force.

Here are presented a few of the different CPM device: Danninger, Kinetec, Mckelcor, Ormed, Optiflex. Generally the

CPM devices operate separately for the knee only or the ankle only.

The Kinetec Spectra Knee CPM for knee patients (Figs. 1 and 2) can now be addressed with a carriage that accommodates all patients, age 8 to 80.

Kinetec Performa Knee CPM equipped with a reliable, smooth and quiet screw-drive transmission. Standard features include seven speed settings, manual set-up mode, programmable muscle stimulation and adjustable force settings. Its UL-approved computerized hand control is completely waterproof, and its built-in pediatric capability eliminates the need for costly attachments for children and shorter adults.

The Optiflex and McKelcor (Figs. 3 and 4) have an innovative, sleek upper carriage which produces a very durable and comfortable CPM, extended range of motion within a compact design that is capable of accommodating patients with limb lengths up to 106mm.



Fig. 1 Kinetec Spectra Knee CPM



Fig. 2 Kinetec Performa Knee CPM



Fig. 3 OptiFlex Knee CPM



Fig. 4 McKelcor DC Knee CPM

Many researchers have developed different rehabilitation devices. For example, Krebs et al. have developed and have been clinically evaluating a robot-aided neuro rehabilitation system called MIT-MANUS [4]. This device provides multiple-degree of freedom (DOF) exercises of upper extremities for stroke patients. They are not actively controlled and do not incorporate any feedback from the patient during the motion. Also, the patient's reactions during the exercises need to be taken into consideration to change and control the exercises actively as a real physiotherapist will do. This can only be done with intelligent devices which can decide the type and pace of exercises based on the patient's complaints and reactions during the physiotherapy.

This paper is focused on the development and testing of a new type of controllable complex (active and passive) knee and ankle rehabilitation device with online feedback.

Here an intelligent control structure with four degree of freedom mechanical system is proposed. It can make flexion-extension for the knee joint, plantar flexion-dorsiflexion, abduction-adduction and inversion-eversion movement for the ankle joint. This manipulator is driven by appropriate actuator for each joint (for instance stepper or DC motor, voice coil

actuator etc.) and controlled by a microcontroller using force/torque with online feedback and position sensor information.

The key features of the device will include: a compact design with highly tunable force/torque capabilities, control circuitry, sensors, and real-time closed loop computer control for optimizing rehabilitation exercises. Algorithms for synthesising appropriate control of the knee and ankle joints will also be developed.

The mechatronic system will operate in two modes; learning and therapy. The control technique is selected for the force control which aim is to specify the relationship between position and force. Proposed intelligent controller structure is used to tune the parameters and can modify itself according to the reactions of the patient.

A continuous passive motion (CPM) device in some cases is not suitable for active physical therapy. For example, during the rehabilitation process, patients sometimes move their extremities suddenly due to reflexes. On conventional machines like CPM, don't respond in this kind of situations and continue the given cyclic motion. If a reflex causes a patient's leg move while the machine is operating, an improper load results and can damage the patient's muscle or tendon tissue [5].

Because of these disadvantages, there is a need to create a new **intelligent device which can accomplish the rehabilitation of extremities based on the patient's complaints and the online feedback during rehabilitation processes.**

The aim of the project is to enhance the intelligent control and sensor technology to be applied in an innovative, accurate and easy to use rehabilitation system. This will improve the quality of the rehabilitation and the postoperative process.

IV. MAIN CHARACTERISTICS OF THE SYSTEM

The rehabilitation system will perform the flexion-extension motions for the knee rehabilitation. It can make flexion-extension, plantar flexion-dorsiflexion, abduction-adduction and inversion-eversion movement for the ankle joint. The device has to be designed for both left and right lower limb. In addition, it can be adjusted for different limb dimensions.

The devices mechanical structure will use the classical methods for fixation the knee and ankle.

The rehabilitation device must have the following main characteristics:

- Automatic anatomically correct alignment,
- Feedback force control to evaluate and limit the amount of force,
- Speed control: from 40°/minute to 145°/minute
- Effective passive mobilization of the joint;
- Multi-Mode operation – active, passive and their combination during every cycle, pause in flexion or extension;
- Adjustable in length from small children to large adults.
- Remote control with digital display allowing easy adjustment of all parameters - range of motion, speed, pause and timer;
- Large range of motion: knee -3° to 130°; ankle plantar flexion 40° dorsiflexion 30° internal rotation 30° external rotation 30°;
- Patient and user safety: The patient can stop and reverse the unit at any time; The movement reverses if the load is excessive,

V. SYSTEM HARDWARE CONTROL AND ACQUISITION

The system hardware for controlling the manipulator is shown on Fig. 5. System hardware will consist of a stepper motor with its driver, force/torque sensor and controller for measurement of force and torque data that come from therapist and patient. Position data will be taken by encoder emulation. Autonomous control system is developed for obtaining and visualizing of human motion data. The developed system is consisted of sensing, data acquisition and graphical user interface (GUI). A microcontroller transfers recorded data during each cycle to the PC via RS485 interface.

The complete autonomous system consists of four primary components - sensing, data acquisition, communication and friendly oriented software for interpretation of the data. Sensing involves the devices that interact with the physical world and give information about it. Data acquisition gathers and digitizes the information from the sensors. Communication takes this data and makes it available through the RS-485 lines. Once the data is transferred, a variety of different interpretations are possible with PC. A graphical user interface will be created to visualize downloaded data.

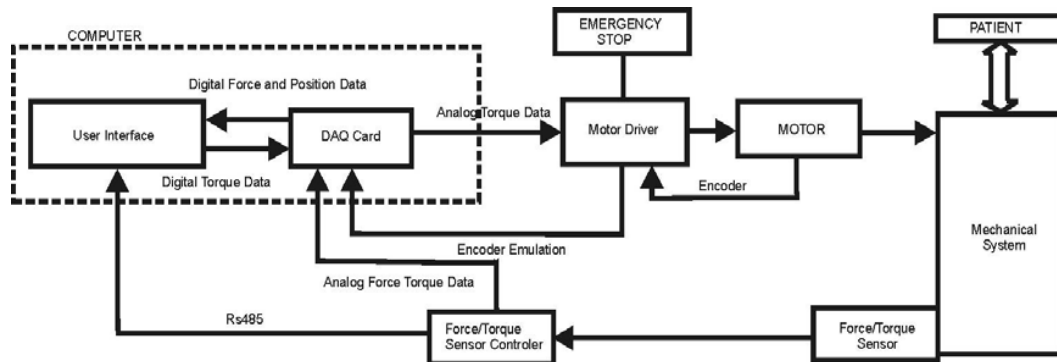

Fig. 5 System Hardware Block Scheme

The proposed control system will be designed and tested. External sensors and encoders measure knee and ankle joint position in real-time and send signals to the microcontroller. These sensors data are used in every step of the control algorithm in order to optimize the force and position during the motion.

The microcontroller serves a few different functions. For communication, its job is to collect sensor data and create a serial bitstream. In order to get all of the data needed, we had to coordinate all of the different features of the microcontroller: analog and digital I/O as well as A/D conversion. For each individual sensor, efficient code was written for the processor to integrate all of the data into a single serial stream.

In order to fulfill more complex functions for passive and active rehabilitation, an intermediate controller is provided. In view of the requirements to this controller (speed, enough input-outputs, communication capabilities, coding, tools for coding), we have chosen a microcontroller of the company **Freescale**/former Motorola/ from the family MC9S12A with the following characteristics: 16 bitCPU, working frequency up to 25 MHz, 64 KB flashEEPROM, 4 KB RAM, 1 KB

EEPROM, 29 digitalinput-outputs, 2 x 8 10 bitanalogchannels, serial peripheral interface /SPI/. Taking into account the price, we have chosen the microcontroller MC9S12A32. The structure of this family is shown in Fig. 6.

A. Intelligent Controller

The mechatronic system will be controlled by an intelligent controller which will incorporate the preloaded data about the patient and provide an interface for information flow between the manipulator and patient.

The TMC428 (Trinamic Motion Control Ltd.) is a miniaturized low cost and high performance stepper motor controller for up to three motors – Fig. 7. It integrates all real time critical tasks in reliable, dedicated hardware: An integrated motion ramp profile generator as well as an adaptable micro step sequencer with micro step RAM table.

Advanced stop- and reference switch handling allows precise and fast referencing as well as on-the-fly position checking. Automatic motor current control gives high motor dynamics while saving energy. The interrupt output can generate precise position pulses.

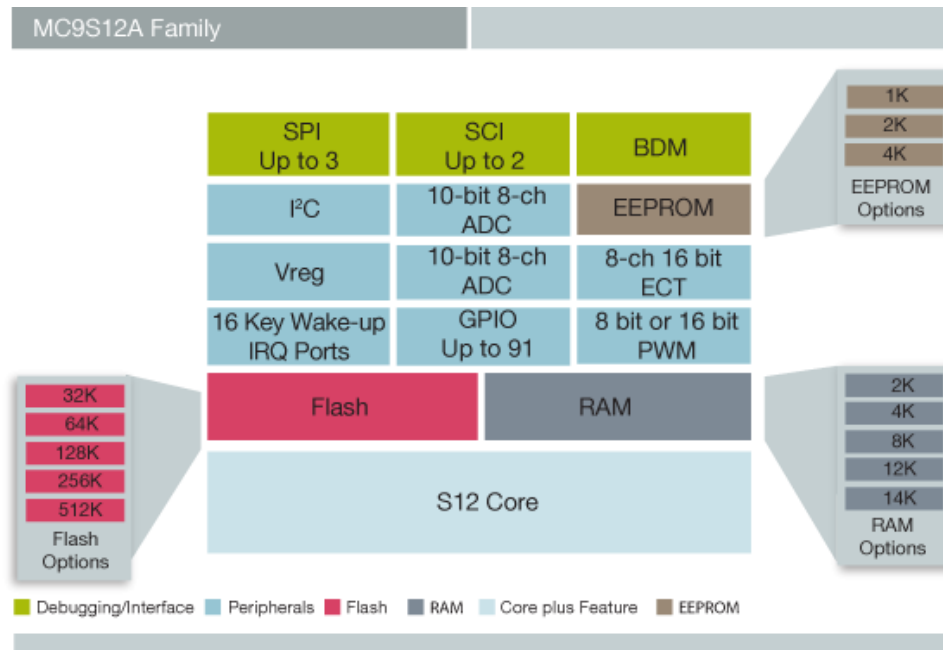

Fig. 6 Intermediate controller

VI. THE ENCODER AND THE MOTOR

The TMC423 adds encoder functionality to the TMC428.

Evaluation Boards, application notes, spreadsheets for parameter calculation, C code examples and schematics are available in order to support short design-in times.

A. Main Characteristics

- unique miniaturized stepper motor controller realized as low power 0.35 μ m CMOS device
- up to three stepper motors with up to 64 times micro stepping
- full step frequencies up to 20 kHz
- driver status information read back for μ C
- power down mode

B. Interface

- SPI μ C interface; easy-to-use protocol for μ C; serial 4-wire driver interface (SPI); step-/direction output

The TMC423 is a triple incremental encoder input chip, which interfaces to any SPI compatible controller. It integrates 24 bit counters – one for each encoder – to provide a high position resolution without CPU interaction. The TMC423 is intended as a companion chip for the TMC428 but not limited to this. Both ICs together enable the realization of a motion control system of three axes with encoder feedback. This provides position verify caution or stabilization by implementation of some additional software. Further, the TMC423 allows dynamic resolution adaptation for direct comparison of encoder counters with motors using different micro step resolution.

All encoder counters can be latched synchronously, or whenever a null channel event occurs, providing a position on strobe holding function. The TMC423 also provides a

step/direction output with programmable signal shaping for the TMC428 as well as a multiplexer function for the TMC428 reference switches. Additionally, the TMC423 can drive an LED matrix and read out a switch matrix, to support systems with keyboard user interaction.

C. Main Characteristics

- incremental encoder interface for three 2 or 3 channel encoders
- TMC428 step / direction interface extension
- TMC428 reference switch interface
- TMC428 interrupt de-multiplexer
- control of LED 6 x 4 Matrix; control of key 6 x 4 matrix

D. Interface

- SPI interface to microcontroller

We intend to use convenient controller electronic with a range of appropriate motor torques. The PD-110-42 offers three motor torque options and can be controlled via RS232, RS485, CAN or IIC interface (Fig. 8). The power supply, interface and the multipurpose I/Os can be connected with small JST connectors. The PD-110-42 comes with the PC based software development environment TMCL-IDE for the Trinamic Motion Control Language (TMCL). Using predefined TMCL high level commands like „move to position“ or „constant rotation“ a rapid and fast development of motion control applications is guaranteed. Communication traffic is kept very low since all time critical operations, e.g. ramp calculation are performed on board. The TMCL program can be stored in the on board EEPROM for stand-alone operation. The firmware of the module can be updated via the

serial interface. With the Stall Guard feature it is possible to detect motor overload or motor stall.

The system has two main stages: learning and therapy.

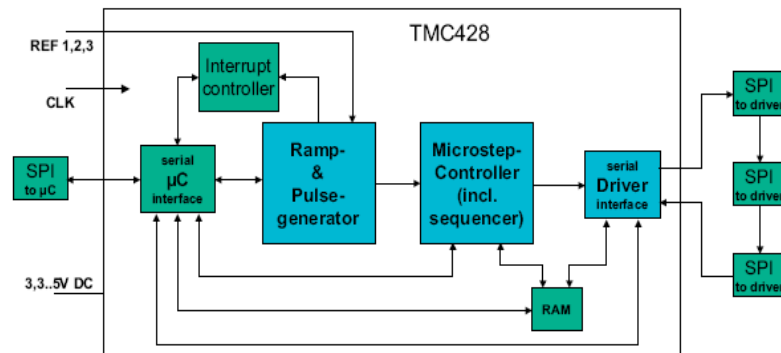

Fig. 7 Three Axis Stepper Motor Controller Block Scheme

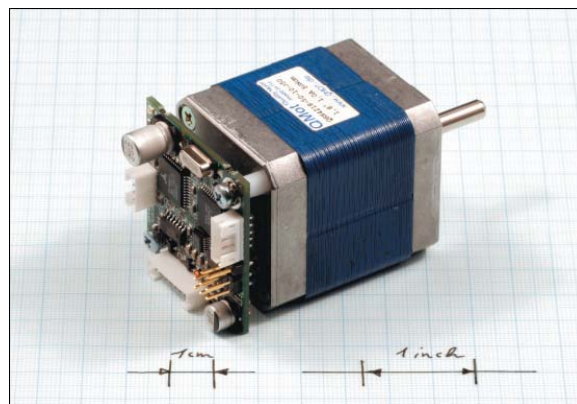

Fig. 8 Stepper Motor 42mm with Intelligent Electronics and Serial Interface

Through user interface, physiotherapist will be able to select exercise mode covering information regarding exercises and patient extremities. Some exercise modes may not need learning process. In these modes, physiotherapist will enter exercise information to start the system for therapy. According to the selected mode, necessary parameters will be taken from the knowledge base.

In the exercise modes that need learning process, the rehabilitation process will be performed by physiotherapist and the mechatronic system will be marked it. During the rehabilitation process, the realized forces that arise and position data are taken by parameter estimation unit to estimate control parameters. Estimated parameters (inertia, stiffness, velocity), desired force and position data are conveyed to the knowledge base.

In *therapy* stage, the mechatronic system will perform therapy motion instead of physiotherapist or the other therapeutic exercise devices. Using force and position sensors, the reactions that come from the knee will be taken by feedback to the manipulator and these data are received by rule base and the system tunes the forces or stop the rehabilitation process, if requires.

According to the patient reactions during the rehabilitation process, the intelligent controller will

evaluates the situation. These conditions will be monitored by force and position sensor.

The system security is controlled by both hardware (limit switches) and software if the motion of manipulator is increased over the limits.

The characteristics for assessing knee and ankle performance are associated with:

- More sophisticated and **efficient rehabilitation** of the knee and ankle joints;
- Automatic **examination and calibration** procedures reducing the human errors;
- Advanced **sensor and feedback** based control (compliance, force, interactive dynamic control) providing a reliable and safe human-machine interaction;
- Data acquisition and sophisticated computer evaluation based on clinical experience, allowing an **accurate, objective, repeatable and well-understood manipulation**;
- The proposed rehabilitation system consists of the following **modules and components**:
- Safety electromechanical system for realization of the motions;

- Sensory system (motion sensors, force sensors, wire position sensors) collecting the information about actual knee motion and providing the feedback for the control system;
- Control system for the force/torque and position in each mode;
- Rehabilitation planning and programming system (user interface);
- Visual and auditory feedback system with user and patient interfaces;

The rehabilitation system will be developed as a stand-alone module that can be integrated with various rehabilitation devices and subsystems.

VII. CONCLUSION AND RESULTS

The system is expected to be a very useful one for supporting the knee rehabilitation and restoration of motor functions. This safe, reliable and dynamically controlled device will support the patients to autonomously perform the knee recovery training from the early rehabilitation stage on the new quality level.

The realization combines the following medical and technical activities:

- Planning, programming and realization of the repetitive functional knee training taking into account biomechanical patterns as well as specific patient disorders and disabilities (dislocations, spasticity, muscle strength, etc.);
- Programmable and dynamically controlled flexion-extension, pronation-supination and adduction-abduction motions on the lower limb joints;
- Assessing and supporting the own initiative, efforts and will of the individual. Quantitative measurements of patients motor-functions (limb motion, forces, mechanical work etc.) needed to assess and document rehabilitation outcome and improve therapeutic approaches.
- Storage of patient data to study the progress of rehabilitation;
- Minimum alteration of the loads and pressures applied to the lower extremities during the active/ passive mode;
- Minimal maintenance and medical staff exertion;
- The system will be designed to support the knee restoration of the various patient groups with orthopedic disorders, such as complicated fracture-dislocations (with open fixations), simultaneous surgery at both extremities (e.g. total knee replacement and high tibialostheotomy), total hip replacement or bedridden elderly patients with multiple pathologies, (cardiac or pulmonary disorders).

ACKNOWLEDGMENT

The research work reported in the paper is partly supported by the project AComIn "Advanced Computing for Innovation", grant 316087, funded by the FP7 Capacity Programme (Research Potential of Convergence Regions).

REFERENCES

- [1] Salter RB, Hamilton HW, Wedge JH, et al. Clinical application of basic research on continuous passive motion for disorders and injuries of synovial joints: a preliminary report of a feasibility study. *J Orthop Res.* 1984;1:325-42.
- [2] O'Driscoll SW, Giori NJ. Continuous passive motion (CPM): theory and principles of clinical application. *J Rehabil Res Dev.* 2000;37:179-188.
- [3] Hammesfahr R, Serafino MT. CPM: The key to successful rehabilitation. *Orthopedic Technology Review.* 2002;3(2).
- [4] Stone KR, Walgenbach AW, Freyer A, Turek TJ, Speer DP. Articular cartilage paste grafting to full-thickness articular cartilage knee joint lesions: a 2- to 12-year follow-up. *Arthroscopy.* 2006;22:291-99.
- [5] Lum P.S., Bugar C.G., Van der Loos H.F.M. (1999), *Proc Int. Conf. On rehabilitation Robotics:* 235-239