

Identification and Classification of Plastic Resins using Near Infrared Reflectance Spectroscopy

Hamed Masoumi, Seyed Mohsen Safavi, and Zahra Khani

Abstract—In this paper, an automated system is presented for identification and separation of plastic resins based on near infrared (NIR) reflectance spectroscopy. For identification and separation among resins, a "Two-Filter" identification method is proposed that is capable to distinguish among polyethylene terephthalate (PET), high density polyethylene (HDPE), polyvinyl chloride (PVC), polypropylene (PP) and polystyrene (PS). Through surveying effects of parameters such as surface contamination, sample thickness, label and cap existence, it was obvious that the "Two-Filter" method has a high efficiency in identification of resins. It is shown that accurate identification and separation of five major resins can be obtained through calculating the relative reflectance at two wavelengths in the NIR region.

Keywords—Identification, Near Infrared, Plastic, Separation, Spectroscopy

I. INTRODUCTION

PLASTIC is one of the most widely used materials in a variety of industries. They are essential part of our everyday lives and due to their short lifetime, it is not surprising that they accounts for large of amounts of waste that is generated. This increases the urgency and importance of plastic recycling. The challenge of municipal solid waste (MSW) management has become a priority for governments all over the world [1]. Separation and sorting of plastic resins from MSW are the major steps in plastic recycling. Wide ranges of plastic resins in use of which most are incompatible to each other, pose a unique challenge for the recycling process. The separation of the different polymers by type is almost always mandatory because contamination in the recycling of one type of plastic by another type can cause serious processing problems [2]. For example, more than 50 parts per million (ppm) of polyvinyl chloride in polyethylene terephthalate would make the entire batch of the resin unusable. The presence of polyvinyl chloride in the polyethylene terephthalate recycling process is harmful, due to the presence of chlorine, and lowers the product quality, namely colour and viscosity [3,4].

Sorting of plastic resins is usually performed with separation among five major resins of polyethylene terephthalate (PET), high density polyethylene (HDPE), polyvinyl chloride (PVC), polypropylene (PP) and polystyrene (PS).

H. Masoumi is with the Department of Mechanical Engineering, Golpayegan Branch, IAU, Golpayegan, Iran (phone: 0098-3723487710; fax: 0098-3723487682; e-mail: h.masoumi@me.iut.ac.ir).

S. M. Safavi is with the Mechanical Engineering Department, IUT - Isfahan University of Technology, Isfahan, Iran (e-mail: mosafavi@cc.iut.ac.ir).

Z. Khani was with Kashan University, Iran (e-mail: zkhani64@yahoo.com).

Methods for identification and sorting of waste plastics range from manual sorting to advanced automated technologies. Sorting and separation techniques are usually based on chemical, optical, electrical or physical property differences between the various plastics to be sorted [5].

Density based sorting methods include float-sink tanks and hydrocyclone. These techniques have been used widely for many years [6].

Another method for identification and sorting of plastics is optical and spectroscopic-based method. Optical and spectroscopic-based sorter can be used to separate plastic on the basis of colour [7,8] or type [9,10]. Also electrostatic sorting techniques can separate different polymer types [11].

Auto-sort technologies based on X-ray detection are generally considered to be the most reliable binary-sort method to remove PVC from a stream of predominantly PET bottles. This is because X-ray sensors only detect the presence of the chlorine atom found in PVC bottles, which is absent in PET bottles. This makes it extremely accurate for differentiating between PVC and PET, but not for identifying other plastic resin types. Because X-rays are a form of radiation, precautions must be taken to protect workers from exposure. X-ray systems include sophisticated shielding to eliminate worker exposure [12].

In 1995, D. M. Scott [9] proposed a method for the identification and separation of PET and PVC resins from each other. He used near infrared radiation (NIR) in this method. The proposed separation method in Scott's paper is based on the using two important peaks in absorbance spectra of PET and PVC. Absorbance peak occurred at 1660 nm for PET and at 1716 nm for PVC. In Scott's method by calculating the ratio of the absorbance at 1716 nm to that at 1660 nm, we can distinguish PET and PVC from each other. According to Scott's observations, the dominant absorbance peak in PET is at 1660 nm, and in PVC this peak is shifted to 1716 nm. As indicated by his results, if the polymer is PVC, then the ratio of the absorbance at 1716 nm to that at 1660 nm will clearly be greater than unity, whereas it will be less than unity in the case of PET. In Scott's paper one lens was used to focus the illuminating NIR source on the sample. Also, a gold-plated screen type of beam splitter was used to separate the transmitted energy into two streams.

In 2001 J. Edward and J.R Sommer [13] invented a method on the basis of Scott's paper for grouping and separation of PET and PVC from each other. Their method was based on the NIR transmission spectra of PET and PVC. They suggested application of an optical filter in preference to using a lens.

In this paper, by generalizing the Scott's method and the Edward's invention, a system is presented for classification of

five important polymer resins, i.e. PET, PVC, HDPE, PP and PS. The proposed sorting system is composed of three major units: identification unit, control unit, and throwing unit. Also, the effects of parameters such as sample thickness; existence of label or cap, and surface contamination on the identification system are investigated.

II. MATERIALS

For finding identification system, samples made of PET, HDPE, PVC, PP and PS were collected. Some of samples were clear, some were white, and some were colored; however, samples of dark colors weren't used. In total 159 samples from a municipal waste disposal site of the city of Isfahan consisted of plastic bottles, containers and ... were collected for the test. 31, 34, 32, 30 and 32 samples from PET, HDPE, PVC, PP and PS were surveyed, respectively. These samples generally included various bottles and containers in MSW with different sizes. Their dimensions were varied from 6-14 cm² to 16-40 cm². The samples were converted to a flat form. Flattening of samples has been carried out by bottle flattener-perforator machine. This machine is an essential part of the plastic sorting process. It squashes the bottles so they do not roll about while being scanned by the Auto-sort machines; it sieves out any remaining bottles tops, which contaminate the plastic. Flattening the containers reduce rolling and other movement on the accelerating conveyor belt. Flattened or partially flattened bottles can scatter the detection beam, which prevents the sensor from getting a reading on the other side.

The samples were not cleaned prior to testing, and in some cases were notably dirty on their surfaces. Studied samples did not include labels and caps.

PVC samples have been included various fillers such as montmorillonite, silica, calcium carbonates and Titanium dioxide.

The NIR reflectance spectra of these samples in the wavelength range of 700 to 2000 nm were measured using a UV-VIS-NIR spectrometer (trade mark of JASCO V-570). For registering the reflectance spectra, a JASCO ARN-475 accessory unit was connected to the spectrometer.

III. METHODS

A. Optoelectronic Sorting of Plastic

The optoelectronic sorting system is composed of three major units: identification unit, control unit, and throwing unit. A simplified schematic of the proposed sorting system is shown in Fig. 1.

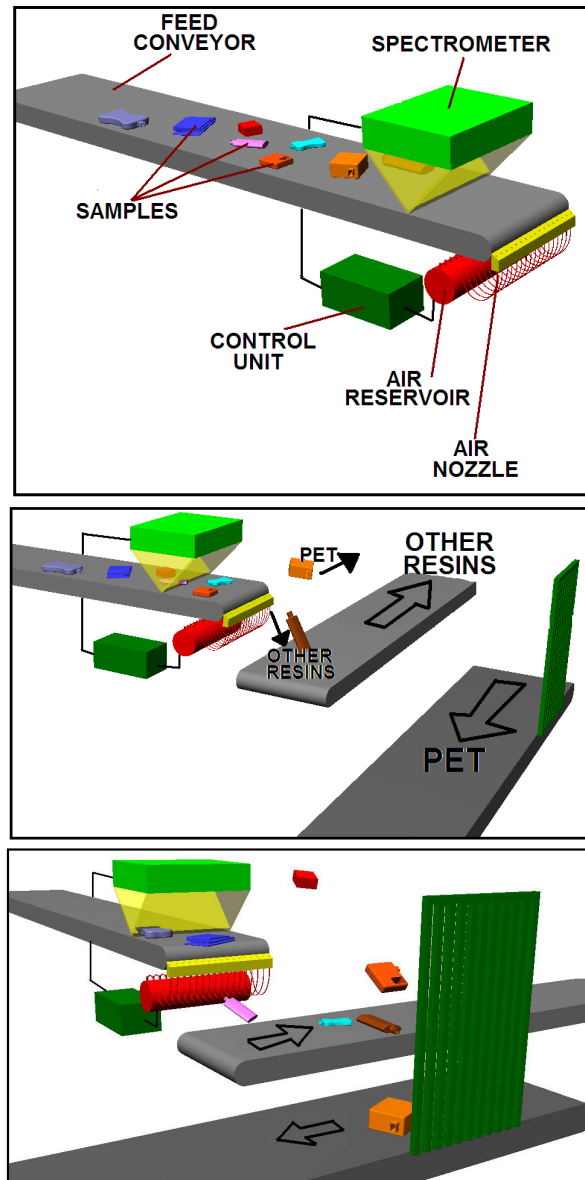

Fig. 1 The schematic of optoelectronic sorting system

As seen in Fig. 1, the mixed plastic container and bottle stream is fed onto a high-speed conveyor belt, which serves to disperse the individual items of the plastic waste stream across the length and width of the conveyor belt. Spreading out the material facilitates the identification of the material of construction of each item as it passes through the identification unit.

As each item passes under the optical sensors, the material of construction of each item is determined by the identification unit and control unit. Target resins, are ejected from the material stream by ejection nozzles (using compressed air) onto a further conveyor belt. The target resin in Fig. 1 is PET. The remaining products that are not targeted will not be subject to the throwing unit and will fall to another conveyor belt due to gravity.

The throwing unit is composed of a compressor and electro pneumatic valves. The valves are put at the bottom of the conveyor belt to be actuated as soon as the throwing command is received by the control unit.

The LabVIEW software and data acquisition (DAQ) card are used in the control unit. The main task of the control unit is the execution of identification and recognition procedure for the desired material, and then the transmission of a suitable command to the throwing unit.

B. NIR Reflectance Spectra

The NIR region covers the wavelength range of about 700 to 2500 nm. The samples spectra are independent of color in this region. On the other hand, NIR spectra of common plastics found in MSW are quite distinct. For these reasons it is ideal for plastic identification and sorting. Thus, the principal operation of the identification unit is based on the NIR reflectance spectroscopy.

The basis for quantitative analysis of spectroscopy is the Beer-Lambert law. The Beer-Lambert law [14] states that absorbance (A) is directly proportional to the thickness of the sample

$$A_{(\lambda)} = Ln(I_{0(\lambda)} / I_{1(\lambda)}) = Ln(1/T) = abc. \quad (1)$$

In (1), $A_{(\lambda)}$ is the absorbance at a particular wavelength λ , $I_{0(\lambda)}$ is the intensity of light incident to the sample, $I_{1(\lambda)}$ is the intensity of passing light, a is the molar absorptivity of the absorber, b is the distance the light travels through the sample (the path length or sample thickness), and c is the concentration of absorbing species in the sample.

Fig. 2, shows the NIR reflectance spectra of two HDPE in blue and green color.

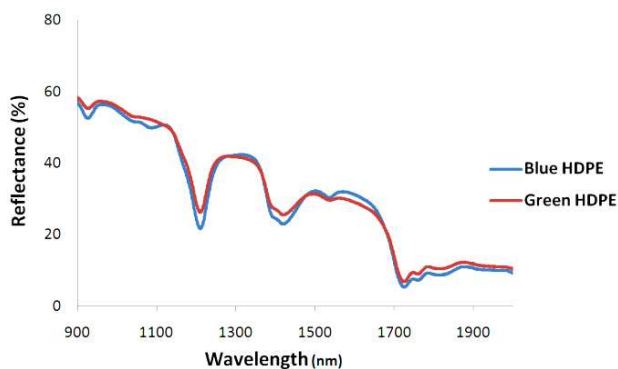

Fig. 2 The NIR reflectance spectrum of blue and green HDPE

As seen in Fig. 2, the overall shape of spectra in the NIR region do not change even with variation in color, and spectra peak points are fixed for a given resin. Infrared spectra of waste plastics provide more detailed information of the chemical composition [15]. The absorbance and reflectance of light in NIR spectral range is due to overtone or combination vibrations of plastic resin molecules. The C-H, O-H, N-H and

C-O bonds observed in NIR spectra can be characteristically attributed to specific plastic resins, thus enabling identification of most commonly used plastics [5].

As presented in Fig. 3, the NIR reflectance spectra of common resins found in industrial and municipal waste streams are quite distinct. For this reason, the NIR reflectance spectroscopy method is appropriate for plastic identification and separation.

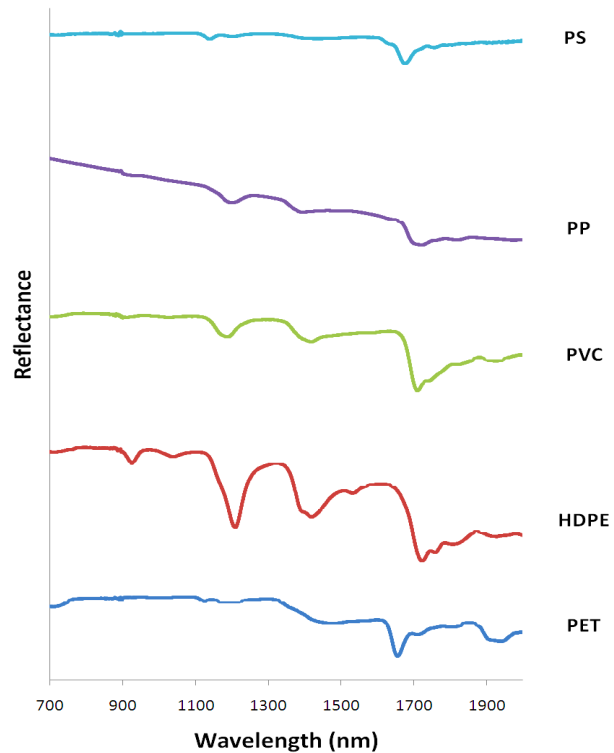

Fig. 3 The reflectance spectra of five resins

The reflectance spectra in Fig. 3 are drawn with offset to avoid interference with each other to improve clarity.

The NIR spectroscopy method is not suitable for identification of dark colored plastics. This disadvantage of NIR method for sorting of waste plastics has been shown in Fig. 4. As seen in Fig. 4, black PVC absorbs more NIR light; so its spectrum is quite different from reflectance spectrum of white PVC. Note that no spectral structure is obtained for the black plastic using NIR reflectance spectroscopy [5].

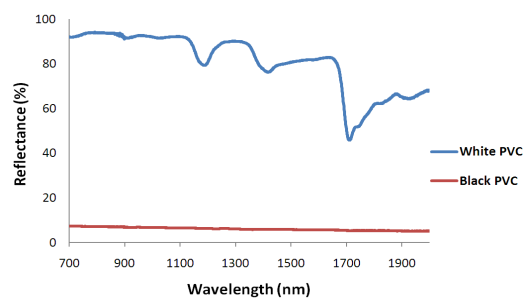

Fig. 4 The NIR reflectance spectrum of Black and white PVC

IV. RESULTS AND DISCUSSIONS

A. Spectral Analysis

According to the acquired NIR reflectance spectra of five major resins PET, HDPE, PVC, PP and PS, an identification system is presented to distinguish between each of them. This system is called the "Two-Filter" method, because two optical filters are used to separate two specific wavelengths of spectrum. By comparing them in the control unit, the resin type will be estimated.

In the spectral region of 700 to 2000 nm, there is only one peak point at the wavelength of 1656 nm for the PET spectrum. However, three important peaks are seen in wavelengths of 1210, 1412 and 1724 nm for the HDPE spectrum. For the PVC spectrum, the most important peak can be seen at 1712 nm. In the case of PP, three peaks at 1199, 1394 and 1721 nm are seen too. PS has only one important peak at 1677 nm. In all 159 surveyed samples, for samples which are made from a specific material, peak points are seen with maximum 3 nm deviation.

Through comparing the acquired spectra of samples which were made of one type of resin, it was obtained that surface dirtiness of samples has no effect in the overall shape of reflectance spectra or the peak points. The only difference between spectra of a given plastic resin is in the total reflectance values.

According to the reflectance and absorbance relation, it can be concluded that absolute reflectance is dependent on a sample's thickness. Relative reflectance, the ratio between absolute reflectance values at two distinct wavelengths, is independent of sample thickness [7]. The identification system can be acquired using this reflectance proportion.

Through surveying the spectral peak points of resins, two wavelengths at 1656 and 1724 nm were selected for acquiring the identification system. These two wavelengths are respectively related to PET and HDPE spectral peak points. Thus by measuring the ratio of reflectance at 1656 nm to reflectance at 1724 nm a simple and reliable identification system can be obtained for recognizing the resin type. The relative reflectance values for 159 samples are shown in table I.

Measuring the ratio of the reflectance at 1656 nm to reflectance at 1724 nm for the 31 samples of PET, yielded an average value of 0.692, with a range of 0.638-0.745. Similarly for the 34 samples of HDPE, the average value of 5.145 with limits of 4.786-5.679 is resulted. For 32 samples of PVC, the average value of 1.466, with a range of 1.299-1.651 were obtained. Regarding PP, 30 samples were investigated of which 16 samples were hard and 14 samples of them were soft. An average value of 3.509 and a range of 2.647-4.224 were obtained. Finally, the average value of 0.955 and a range of 0.921-0.977 were acquired for the 32 samples of PS.

0.726	5.581	1.651	4.224	2.965	0.935
0.673	5.432	1.312	4.122	2.647	0.964
0.638	5.296	1.410	4.215	2.817	0.967
0.665	4.786	1.450	4.181	2.740	0.930
0.696	5.679	1.573	4.016	2.752	0.961
0.691	4.925	1.619	4.154	2.902	0.970
0.712	5.011	1.299	4.176	2.880	0.959
0.729	5.061	1.405	4.094	2.742	0.921
0.699	4.812	1.396	4.117	2.811	0.952
0.681	5.330	1.508	4.208	2.839	0.965
0.711	4.905	1.490	4.061	2.731	0.928
0.701	5.192	1.584	4.152	2.691	0.961
0.649	4.849	1.503	4.198	2.707	0.944
0.722	4.860	1.385	4.215		0.975
0.643	4.903	1.630	4.167		0.956
0.694	5.641	1.469			0.973
0.735	5.071	1.338			0.955
0.642	4.808	1.554			0.947
0.703	5.173	1.622			0.959
0.720	5.420	1.472			0.943
0.688	4.857	1.423			0.972
0.662	5.413	1.536			0.954
0.644	5.517	1.606			0.973
0.650	4.938	1.335			0.961
0.704	5.248	1.356			0.941
0.674	5.239	1.632			0.949
0.690	5.109	1.427			0.933
0.724	4.976	1.377			0.937
0.730	4.795	1.349			0.964
0.745	4.992	1.366			0.969
	5.557	1.445			0.963
	4.859				
	5.047				

From table I, it is obvious that all relative reflectance values are less than 0.8 for PET samples. For HDPE, more than 4.7, for PVC from 1.2 to 1.7, for PP from 2.6 to 4.3, and finally for PS, this value is between 0.92 and 0.98.

Regarding PP, the relative reflectance range for PP is greater than other resins. This is due to the difference between hard and soft polypropylene spectra. This difference in reflectance is a result of the additive materials which are added to PP to achieve the desired hardness properties of the material.

As mentioned in previous, the PVC samples for experimental test have been included various fillers such as silica, calcium carbonates and Titanium dioxide. According to experiments, the overall shape of spectra in the NIR region for various PVC samples do not change even with variation in filler, and spectra peak points are fixed for a given PVC resin. Also, HDPE, PS and PET samples have been included various types and grades. The relative reflectance range for these samples is limited and for each of them the overall shape of spectra in the NIR region for various type do not change even with variation in grade.

The aforementioned conclusions are the basis of operation of a suggested identification unit, which is shown in flowchart form in Fig. 5.

TABLE I
THE RELATIVE REFLECTANCE FOR PLASTIC SAMPLES R(1656)/R(1724)

PET	HDPE	PVC	Hard PP	Soft PP	PS
0.712	5.647	1.394	4.059	2.687	0.977

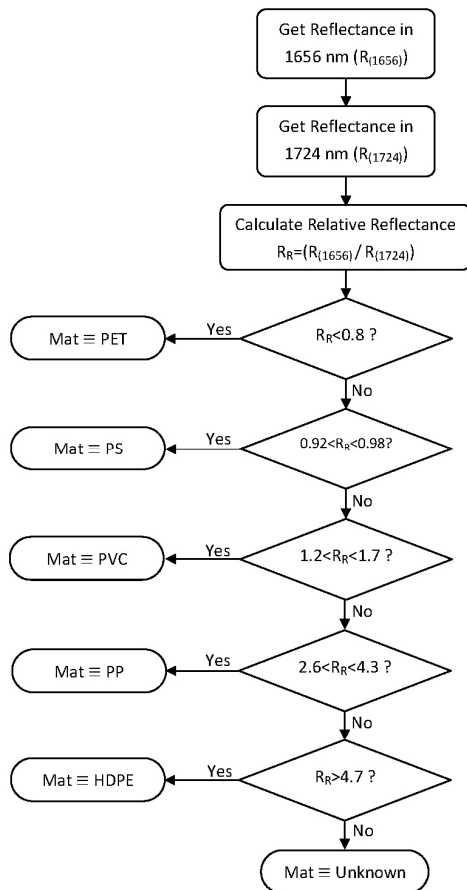

Fig. 5 "Two-Filter" identification flowchart

B. The Optoelectronic Structure of Identification Unit and Control Unit

The most important issue in the identification system with the "Two-Filter" method was limiting the wavelength region of light to two distinct wavelengths. As illustrated in Fig. 6, two optical filters with an operation in two specific wavelengths were used for this purpose.

In an optoelectronic sorting system, plastic material is carried to the inspection station via a conveyor. When the plastic material passes through the inspection station, it is irradiated by a NIR light source. The light reflected from the plastic material is collected at face plate disposed on the end of optical fiber cable. The collected light is carried to the two optical fiber cables. The collected is carried to the respective GRIN lenses and optical filters.

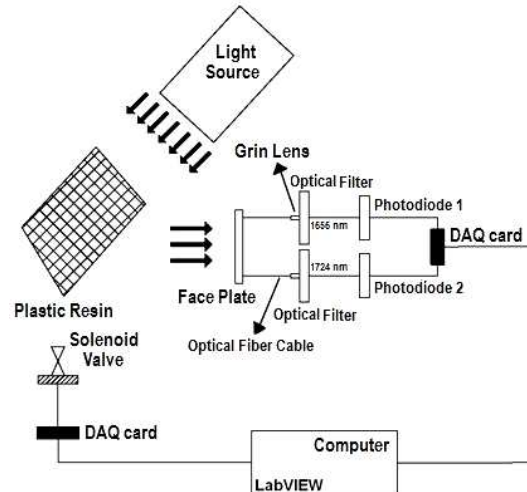

Fig. 6 The optoelectronic structure of sorting system

The optoelectronic sorting system uses a 0.25 pitch GRIN lens to focus and collimate the light sources. The 0.25 pitch GRIN lens normalizes the light incident to the optical filter, because the optical filters are designed for use at normal incidence of collimated light. Certain characteristics of optical filters change with the incidence angle. For instance, the center wavelength, the most important parameter of an optical filter, varies approximately as a cosine function, shifting towards shorter wavelengths with increasing angle. The following equation may be used to determine the wavelength at a certain angle of incidence [16]:

$$\lambda = \lambda_0 \sqrt{1 - (\eta_0 / \eta_{eff})^2 \sin^2 \varphi} \quad (2)$$

where λ , λ_0 , φ , η_0 and η_{eff} are the wavelength at the angle of incidence, the wavelength at normal incidence, the angle of incidence, the refractive index of external medium and the effective refractive index of the filter, respectively.

Two optical filters have been used in optoelectronic system. These optical filters pass a band of wavelengths of light centered on 1656 and 1724 nm. The light wavelengths passing filters were then directed to detectors (i.e. photodiodes such as Indium-Gallium-Arsenide). The photodiode would convert the received electromagnetic energy (in the form of light) into an electric signal (in the form of amperage or voltage). The output of each photodiode is proportional to the rate of NIR reflectance light from the plastic surface at the wavelength of the related filter. The output of the photodiode is sent to a computer via a data acquisition (DAQ) card.

The output of the photodiodes has been seen in the software environment as input through applying DAQ card and via drivers in LabVIEW. Then the type of resin would be recognizable using the written program in LabVIEW environment. The command of actuating or not actuating the solenoid valves would be sent for the actual separation of plastic resins.

C. The Effect of Different Parameters on Identification System

The performance of the identification unit was assessed by evaluating the effect of different parameters. Sample thickness, the existence of a label or a cap, and surface contamination are the most important parameters.

1. Sample thickness

According to the Beer-Lambert law, absolute absorbance (A) is directly dependent on sample thickness. Since, relative absorbance and relative reflectance are both independent of sample thickness. The variation in thickness should not have any effect on identification system operation. Nevertheless, a test was performed on this relation. Five green HDPE samples with thicknesses of 1, 2, 3, 4 and 5 mm were prepared. Their NIR reflectance spectrum was registered. Fig. 7 shows NIR reflectance spectra of these samples.

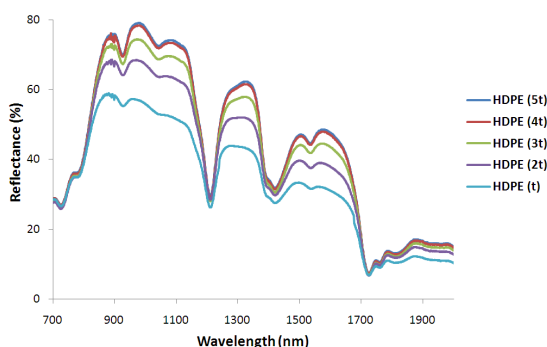

Fig. 7 The reflectance spectra of five green HDPE with thicknesses of 1, 2, 3, 4 and 5 mm

As presented in Fig. 7, absolute reflectance values are increased with increasing thickness. However, the overall form of the spectrum has been still preserved and peak points are fixed. Table II shows the relative reflectance values in two principal wavelengths.

TABLE II

THE RELATIVE REFLECTANCE QUANTITIES IN 1656 AND 1724 NM FOR HDPE WITH THICKNESSES OF 1, 2, 3, 4 AND 5 mm

Thickness (mm)	1	2	3	4	5
$R_{(1656)}/R_{(1724)}$	4.774	5.025	5.332	5.387	5.346

According to the results of table II, the relative reflectance values are within the allowable range for HDPE in the identification flowchart. As seen in table II, by increasing the thickness from 3 to 5 mm, the relative reflectance has had little changes and has reached a rather steady state.

2. Label

The effect of label is demonstrated with the example of a PET bottle that was covered with a label. Fig. 8 shows the corresponding spectra. Spectrum 1 has been obtained from the PET bottle without any label coverage, spectrum 2 from the bottle with 10 percent label, spectrum 3 from the bottle with

35 percent label coverage, spectrum 4 from the bottle with 75 percent label coverage, and spectrum 5 from the label. Other PET bottles with 25 and 50 percent label have been surveyed.

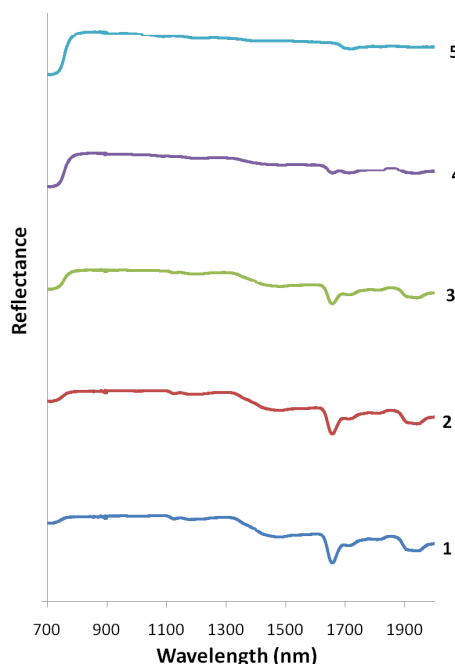

Fig. 8 The reflectance spectra of PET bottle and label: (1) PET bottle without label, (2) PET bottle with 10% label, (3) PET bottle with 35% label, (4) PET bottle with 75% label, (5) label

As presented in Fig. 8, the spectrum of the label has no considerable peak and its reflectance value has little change from 800 to 2000 nm. Table III shows the relative reflectance values of PET, label and the combination of them.

TABLE III

THE RELATIVE REFLECTANCE QUANTITIES AT 1656 AND 1724 nm FOR PET AND THE COMBINATIONS OF PET AND LABEL

Samples	PET	PET (10% label)	PET (25% label)	PET (35% label)	PET (50% label)	PET (75% label)
$R_{(1656)}/R_{(1724)}$	0.673	0.709	0.771	0.795	0.869	0.994

As presented in table III, it can be concluded that the "Two-Filter" system properly distinguishes the existence of PET even when the PET surface is 35 percent covered with label material. In the case of 35 percent label coverage, the relative reflectance value of 0.795 has been acquired. On the other hand, in accordance with the identification system, Fig. 5, the relative reflectance values less than 0.8 shows the existence of PET. If the label covers more than 35 percent of the plastic surface, the system provides invalid results. Of course, a bottle or a plastic container with label coverage of more than 35 percent is rarely found in practice.

3. Cap

Most of bottles and plastic containers which are ready for separation are with caps. The effective surface of cap is much less than label. Caps are generally made of PP. In the surveyed samples in this section, caps which are made of PP have covered between 2 to 4 percent of the effective PET surface. However, the effect of 10, 25, 35, and 50 percent of cap coverage is also studied. NIR reflectance spectra of PET bottles and caps (PP resin) are shown in Fig. 9. The spectra belong to following samples: 1, PET bottle without cap; 2, PET bottle with three percent cap; 3, PET bottle with ten percent cap; 4, PET bottle with 25 percent cap; 5, PET bottle with 35 percent cap; 6, PET bottle with 50 percent cap, 7, cap coverage.

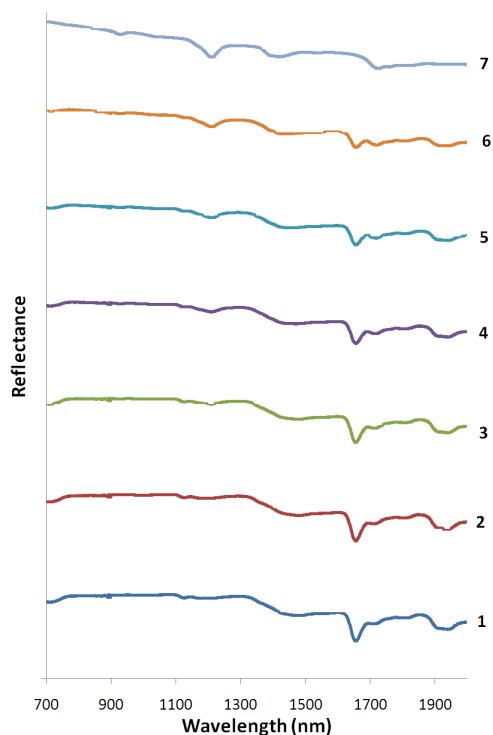

Fig. 9 The reflectance spectra of PET bottle and cap: (1) PET bottle without cap, (2) PET bottle with 3% cap, (3) PET bottle with 10% cap, (4) PET bottle with 25% cap, (5) PET bottle with 35% cap, (6) PET bottle with 50% cap, (7) cap

Table IV shows the relative reflectance values of PET, cap material and the combination of both.

TABLE IV

THE RELATIVE REFLECTANCE QUANTITIES AT 1656 AND 1724 nm FOR PET AND THE COMBINATIONS OF PET AND CAP

Samples	PET	PET (3% cap)	PET (10% cap)	PET (25% cap)	PET (35% cap)	PET (50% cap)
$R_{(1656)}/R_{(1724)}$	0.678	0.684	0.706	0.766	0.818	0.926

According to table IV, the relative reflectance values are increased with increasing the percentage of cap coverage. In

the case of PET bottle with 35 and more percent effective surface of cap, recognized type of material using the "Two-Filter" method will be incorrect. In practice however, the effective percent of cap coverage is very small, so no problem will be encountered during the sorting of PET. Even in a sample with 25 percent cap coverage, the proposed system will determine the existence of PET.

For other resins with different cap material is expected that the proposed system will distinguish the target resin properly. These resins are not expected to cause any trouble in sorting system, because the samples with considerable percent of cap coverage are not often observed in real waste.

4. Surface contamination

Contaminated samples do not affect the quality of NIR reflectance spectra, because in the NIR wavelength region the length of light pass is much higher (about 10 mm at the second CH stretch overtone about 1200 nm) than the layer thickness of the dirt (< 0.5 mm) [17].

The selected samples for spectroscopy were not washed and not cleaned. As such, some of them had a dirty surface. However, after taking spectra, it was concluded that the spectra of dirty samples are similar to spectra of clean samples for a given resin (Fig. 10).

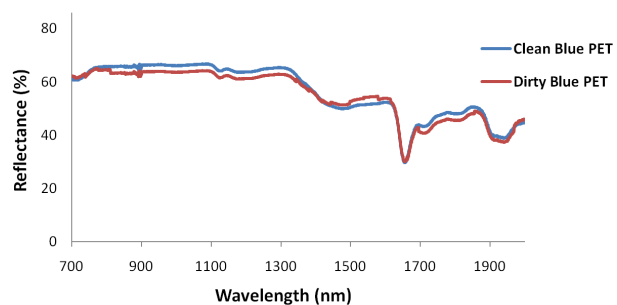

Fig. 10 The NIR reflectance spectra of clean and dirty blue PP

D. Cost Considerations

With all sorting categories available for plastic type and color separation, the infrastructure and operational cost would arise as a serious challenge for the success of an automatic sorting system [8]. The proposed identification and classification system represents a significant portion of the costs associated with the recycling process. In the current work, identification hardware and classification system required costly component such as optical filter, DAQ card, GRIN lens, face plate, optical fiber cable, and conveyor belt. However, this method provided a higher value and accurate sorted plastic output. Furthermore, sorting the plastic bottles and containers with this method would result in the considerably value added that legitimizes the costs of identification hardware and sorting system in long term. Furthermore, in other methods such as manual identification and sorting, increasing labor costs are making manual sorting economically unviable. In addition, the resulting product which is costly produced, generally only finds limited

application in low value products, due to the possibility of human error during the sorting operation.

V. CONCLUSION

It has been demonstrated that the identification and separation of plastic resins can be obtained using measurements of the NIR reflectance spectroscopy. An identification system has been proposed that uses only two specific wavelengths in the NIR region. Using this system identification of plastic resins was correctly performed. A reliable separation and sorting among containers and bottles made of PET, HDPE, PVC, PP and PS is possible with the proposed optoelectronic sorting system. Tests in this study have shown that thickness changing of samples, and the existence of a label or a cap are not expected to cause difficulty using the identification system and in optoelectronic sorting system. NIR reflectance spectroscopy offers many advantages for identification and sorting plastic resin, though this method is not suitable for the identification of dark colored plastics.

REFERENCES

- [1] Zhuang, Y., Wu, S.W., Wang, Y.L., Wu, W.X., Chen Y.X., "Source separation of household waste: A case study in China" *Waste Management* 28, 2008, pp. 2022–2030.
- [2] Carvalho, M.T., Ferreira, C., Portela, A., Santos, J.T., "Application of fluidization to separate packaging waste plastics" *Waste Management* 29, 2009, pp. 1138–1143.
- [3] Awaja, F., Pavel, D., "Recycling of PET. *European Polymer Journal* 41, 2005.
- [4] Navarro, R., Ferrándiz, S., López, J., Seguí, V.J., "The influence of polyethylene in the mechanical recycling of polyethylene terephthalate" *Journal of Materials Processing Technology* 195, 2008, pp. 110-116.
- [5] Scheirs, J., *Polymer Recycling*, Wiley Publication, 1998.
- [6] Enick, R., "The microsotation of post-consumer thermoplastics using near critical liquids" *proc. Globec 96*, Davos, Switzerland, 1996, pp. 18-25.
- [7] Safavi, S.M., Masoumi, H., Mirian, S.S., Tabrizchi, M., "Sorting of polypropylene resins by color in MSW using visible reflectance spectroscopy" *Waste Management* 30, 2010, pp. 2216-2222.
- [8] Tachwali, Y., Al-Assaf, Y., Al-Ali, A.R., "Automatic multistage classification system for plastic bottles recycling" *Resources, Conservation and Recycling* 52, 2007, pp. 266-285.
- [9] Scott, D.M., "A two-color near-infrared sensor for sorting recycled plastic waste" *Measurement Science and Technology* 6, 1995, pp. 156-159.
- [10] Sommer, E. J., "Methods and technologies for post-consumer plastic identification and sortation" *Proc. SPE 3rd Annual Recycling Conf.*, Chicago, IL, Nov., 1996, pp. 299-304.
- [11] Incelet, I., "Electrostatic separation of mixed plastic waste" *Proc. Davos 92 Recycle*, 1992.
- [12] American Plastics Council., "Best Practices in PET Recycling, Automated Sorting Systems" NAPCOR, 1997.
- [13] Edward, J., Sommer, J. R., "Method and Apparatus for Near Infrared Sorting of Recycled Plastic Waste" Patent, United States, Pub. No.: US 2001/0045518 A1, 2001.
- [14] Robinson, J.W., *Undergraduate Instrumental Analysis*, sixth ed. M. Dekker Publication, 2005.
- [15] Smidt, E., Meissl, K., Schwanninger, M., Lechner, P., "Classification of waste materials using Fourier transform infrared spectroscopy and soft independent modeling of class analogy" *Waste Management* 28, 2008, pp. 1699–1710.
- [16] Optical Components and Assemblies, Optical Filters, <http://www.cvilaser.com>, 2009.
- [17] Feldhoff, R., Wienke, D., Cammann, K., Fuchs, H., "On-line post consumer package identification by NIR spectroscopy combined with a FuzzyARTMAP classifier in an industrial environment" *Applied Spectroscopy* 51, 1997, 362-368.