

Variable-Relation Criterion for Analysis of the Memristor

Qingjiang Li, Hui Xu, Haijun Liu, Xiaobo Tian

Abstract—To judge whether the memristor can be interpreted as the fourth fundamental circuit element, we propose a variable-relation criterion of fundamental circuit elements. According to the criterion, we investigate the nature of three fundamental circuit elements and the memristor. From the perspective of variables relation, the memristor builds a direct relation between the voltage across it and the current through it, instead of a direct relation between the magnetic flux and the charge. Thus, it is better to characterize the memristor and the resistor as two special cases of the same fundamental circuit element, which is the memristive system in Chua's new framework. Finally, the definition of memristor is refined according to the difference between the magnetic flux and the flux linkage.

Keywords—Memristor, Fundamental, Variable-Relation Criterion, Memristive system

I. INTRODUCTION

FROM studying circuit theory, we learn that there are only three fundamental circuit elements: the resistor R , the capacitor C , and the inductor L . However, in 1971 L. Chua reasoned from symmetry arguments that there should be a fourth fundamental circuit element, which he named memristor [1]. In 2008, R. S. Williams and his team, at HP Labs, declared their realization of the first memristor prototype [2]. As one of the future generation of universal memories, the memristor has drawn a great deal of research interests [3]-[5].

The unique characteristics distinguish memristor from three traditional fundamental circuit elements. However, whether the memristor can be interpreted as the fourth fundamental circuit element is still under debate. At the 2010 IEEE Symposium on Circuits and Systems, one of the presentations entitled "The mythology of the memristor" by B. Mouttet argued that the interpretation of the memristor as the fourth fundamental circuit element may seem like a reasonable argument at first glance but it is not without flaws [6]. In 2009, M. D. Ventra, Y. V. Pershin, and L. Chua formed a new framework in [7] presenting an

expanded view of circuit theory. This paper is indicative of the idea that the memristive system, the memcapacitive system, and the meminductive system are generalizations of the three fundamental circuit elements, while the memristor and the resistor are two special cases of the memristive system [7]-[10].

In this paper, we review the theory of memristor and investigate the unique i - v characteristics of memristor. Then, we put forward a variable-relation criterion of fundamental circuit elements and show that three traditional fundamental circuit elements built direct relations between pairs of the four fundamental circuit variables. However, according to the Maxwell's equation and the difference between the magnetic flux and the flux linkage, we show that the memristor build a direct relation between the voltage and the current instead of between the magnetic flux and the charge. So, it is better to characterize the memristor and the resistor as two special cases of the same fundamental circuit element, which is the memristive system in Chua's new framework.

Finally, the definition of memristor is refined, according to the difference between the magnetic flux and the flux linkage.

II. THEORY OF MEMRISTOR

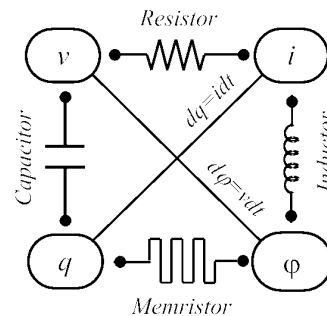

Fig. 1 The four fundamental circuit elements: resistor, capacitor, inductor and memristor. Three traditional fundamental circuit elements are associated with pairs (dv, di) , (dv, dq) , and $(d\phi, di)$. This leaves the pair $(d\phi, dq)$ unrelated. L. Chua reasoned that the unrelated pair indicates the fourth fundamental circuit element

As shown in Fig. 1, there are six possible mathematical relations connecting pairs of the four fundamental circuit variables: electric current i , voltage v , charge q , and magnetic flux ϕ [2]. Charge q and current i are related by the definitions of two of the variables, and the relation between magnetic flux ϕ and current i is determined from Faraday's law of induction. Three of the four remaining relations between the variables describe the traditional fundamental circuit elements,

Manuscript received October 12, 2011. This work was supported in part by the National Nature Science Fund Committee 61171017 and the NUDT Outstanding Graduate Research Opportunity Program B110405.

Qingjiang Li is with the National University of Defense Technology, Changsha, CO 410073 China (phone: 86-731-84573010; fax: 86-731-84573010; e-mail: qingjiangli@nudt.edu.cn).

Hui Xu is with the National University of Defense Technology, Changsha, CO 410073 China (e-mail: xuhui@nudt-esss.com).

Haijun Liu is with the National University of Defense Technology, Changsha, CO 410073 China (e-mail: lhj@nudt-esss.com).

Xiaobo Tian is with the National University of Defense Technology, Changsha, CO 410073 China (e-mail: txb@nudt-esss.com).

namely, $R = dv/di$, $C = dq/dv$, and $L = d\phi/di$. Chua argued that the missing link between the magnetic flux ϕ and the charge q describes the fourth fundamental circuit element, which he called memristor [1]. Each memristor is characterized by its memristance function describing the charge-dependent rate of change of flux with charge [11], namely, $M = d\phi/dq$.

Considering that magnetic flux is simply the time integral of voltage, and charge is the time integral of current, we can rewrite the above definition equation to a more convenient form.

$$M(q(t)) = \frac{d\phi}{dq} = \frac{d\phi/dt}{dq/dt} = \frac{v(t)}{i(t)} \tag{1}$$

It can be inferred from (1) that memristance is simply charge-dependent resistance. At constant time t_0 , $M(q(t_0))$ is equal to resistance. However, $q(t)$ will vary with time, and memristance will vary with $q(t)$, which means memristor can memorize the history of the current. When the current is stopped, the memristor retains the last resistance that it had, and when the flow of current starts again, the resistance of the memristor will be what it was when it was last active [11].

Unlike three traditional fundamental circuit elements however, which are allowed in linear time-invariant system theory, the memristor is a nonlinear time-varying element. Meanwhile, the i - v characteristic for a sinusoidal input is a double-loop hysteretic figure, just as Fig. 2 shows.

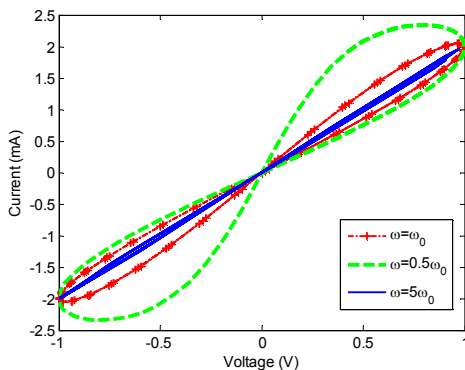

Fig. 2 Theoretical i - v characteristics of a memristor with applied voltage $v(t) = v_0 \sin(\omega t)$ for $\omega = 0.5\omega_0$ (green dash), $\omega = \omega_0$ (red dash-dot) and $\omega = 5\omega_0$ (blue solid), where $v_0 = 1\text{V}$ and $\omega_0 = 0.6\text{rad/s}$. Parameters of memristor are $D = 10\text{nm}$, $R_{\text{off}}/R_{\text{on}} = 3000$, and $R_{\text{on}} = 1\Omega$. It can be observed from Fig. 2 that the hysteresis is suppressed with the increase of frequency

Until now, no combination of nonlinear resistive, capacitive, and inductive components can duplicate the circuit properties of a nonlinear memristor (although including active circuit elements such as amplifiers can do so) [2], which makes memristor interpreted as the fourth fundamental circuit element. However, this is only the linear independence criterion, according to which, we can only characterize memristor as a new circuit element rather than the fourth fundamental circuit element. So, the criterion of fundamental circuit elements should be specified firstly. Then, the emphasis will be laid on

whether memristor accords with the criterion. In this paper, we investigate the fundamental circuit elements from the perspective of variables relation.

III. THE VARIABLE-RELATION CRITERION OF FUNDAMENTAL CIRCUIT ELEMENTS

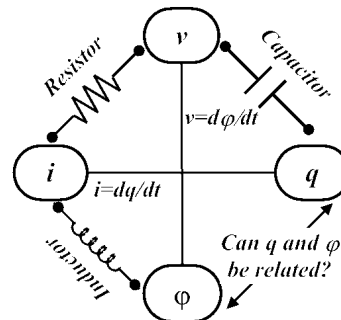

Fig. 3 Relations between four fundamental variables: the voltage v , the current i , the charge q and the magnetic flux ϕ . Five of the six possible relations have already been defined in the circuit theory. From the view of symmetry, the relation between ϕ and q seem like to exist, but the idea may be incorrect considering the real physics meaning of the two variables

It can be inferred from Chua’s paper that the missing relation between the magnetic flux ϕ and the charge q indicates the existence of memristor. From the logical as well as the axiomatic points of view, this inference seems reasonable [1]. But, it may neglect a problem that whether the magnetic flux ϕ and the charge q can be related directly considering the real physics meaning of two of the variables.

A. The Variable-Relation Criterion of Fundamental Circuit Elements

From the view of variables relation, the resistor, the capacitor and the inductor are interpreted as fundamental circuit elements for the reason that they can build a direct relation between two fundamental variables respectively. Besides, the direct relation is determined with the real physics meanings of the variables. More specifically, the resistor can build a direct relation between the potential difference v across the element and the current i through it, the capacitor can build a direct relation between the potential difference v between the plates and the charge q stored at the plates, and the inductor can build a direct relation between the magnetic flux ϕ through the loop and the current through its turns. Consequently, we put forward a variable-relation criterion of fundamental circuit elements, which means that a fundamental circuit element depends on whether it can build a direct relation between two of the variables with real physics meaning. Therefore, as for the memristor, the key lies in whether the memristor can build a direct relation between the magnetic flux ϕ and the charge q with the real physics meanings.

B. Can ϕ and q Be Directly Related?

As the magnetic flux ϕ is the integral of the magnetic induction intensity \mathbf{B} , the direct relation between the magnetic

flux φ and the charge q depends on the direct relation between the magnetic induction intensity \mathbf{B} and the charge q . The Maxwell's equation in the integral form is shown as below:

$$\oint_l \mathbf{H} \cdot d\mathbf{l} = \int_s \mathbf{j} \cdot d\mathbf{S} + \int_s \frac{\partial \mathbf{D}}{\partial t} \cdot d\mathbf{S} \quad (2)$$

where \mathbf{H} is the magnetic field intensity, \mathbf{j} is the current density, \mathbf{D} represents the electric displacement vector and $d\mathbf{l}$ is the infinitesimal element of closed curve l .

It can be learned from (2) that the excitation sources of the magnetic field are only the conduction current i and the displacement current i_D ($i_D = \partial \mathbf{D} / \partial t$). The relation between the magnetic flux φ and the conduction current i has defined another fundamental circuit element, the inductor, whereas the relation between the magnetic flux φ and the displacement current i_D remains undefined. Then, the key lies in whether there is a direct relation between the displacement current i_D and the charge q . Unfortunately, this directly relation does not exist. Thus, the magnetic flux φ can not be directly related with the charge q , and the definition of memristor with the relation between the magnetic flux and the charge may be inaccurate.

C. Magnetic Flux or Flux Linkage

As stated above, the magnetic flux φ and the charge q can not be directly related and the definition of memristor may be inaccurate. However, the existence and uniqueness of the memristor definition is proved in Chua's paper with the nonlinear network theory [1]. The contradiction between the two above facts lies in the difference between the magnetic flux and the flux linkage.

In an inductor, the magnetic flux relates to the Faraday's law of induction, which states that the EMF (short for electromotive force) equals the negative derivative of the magnetic flux through the loop. The minus sign in the equation indicates an opposition effect to work against the applied excitation. The opposition effect of inductor is realized by storing energy in the magnetic field. The term magnetic flux here represents the intensity of the physical magnetic field. If 1V voltage is applied across an inductor for 1 second, then there is 1 V·s magnetic flux in the inductor, which represents a related 1 V·s energy stored in the magnetic field which may later be obtained from it according to the Faraday's law [11].

The nature of memristor is also an opposition effect to the applied excitation, which is realized by dissipating the Joule heating energy instead of storing energy in magnetic or electric field. The same 1V voltage over the same time 1s across a memristor will result in the same flux linkage φ' , which is generalized from the magnetic flux for inductors [11]. The flux linkage is defined by the equation $\varphi' = \int v \cdot dt$, so the dimension of the flux linkage is the same with that of the magnetic flux. However, the flux linkage related energy is dissipated in the form of Joule heating energy, rather than stored in the magnetic field — there is no physical magnetic field involved as a link to anything [11].

To work against the applied excitation, the memristor will produce the flux linkage. The flux linkage has the same dimension with magnetic flux, so it is easy to understand the proof of the existence and uniqueness of the memristor definition [1]. However, the flux linkage does not represent a physical magnetic field, so the definition of memristor should be refined as: The memristor is a passive two-terminal circuit element which maintains a functional relationship between the time integrals of the current through it and the voltage across it, namely,

$$M(t) = \frac{d\varphi'}{dq} = \frac{d\varphi' / dt}{dq / dt} = \frac{v(t)}{i(t)} \quad (3)$$

where φ' is the flux linkage, $v(t)$ is the voltage across the memristor, and $i(t)$ is the current through the memristor.

According to the Maxwell's equation, we have proved that the magnetic flux can not be directly related to the charge, so the characterization of memristor as the fourth fundamental circuit element may be inaccurate. But as (3) shows, the memristor build a direct relation between the voltage across it and the current through it, just like the resistor. According to the variable-relation criterion, the memristor and the resistor should be interpreted as two special cases of the same fundamental circuit element, which verifies Chua's new framework from the perspective of variables relation. It is worth to mention here that the direct relation between voltage and the current in the memristor is different from that in the resistor, as the memristance depends on the integral of the input rather than the instantaneous value of the input.

IV. CONCLUSION

In this paper, we propose a variable-relation criterion of fundamental circuit elements, and analyze whether the memristor can be interpreted as the fourth fundamental circuit element according to the criterion. According to the Maxwell's equation, we analyze the difference between the magnetic flux and the flux linkage, and refine the definition of memristor. From the perspective of variables relation, the memristor build a direct relation between the voltage and the current instead of a direct relation between the magnetic flux and the charge. Thus, we come to the conclusion that the memristor and the resistor are two special cases of the same fundamental circuit element.

Actually, the conclusion accords with Chua's new framework, in which memristive system, memcapacitive system, and meminductive system are interpreted as generalizations of the three fundamental circuit elements respectively, and the memristor and the resistor belong to the memristive system type. Chua's new framework was formed based on the dynamic systems analysis, and our analysis is from the perspective of variables relation.

ACKNOWLEDGMENT

It is pleasure to thank Professor Jianqing Zhu and Professor Jibin Liu for helpful comments.

REFERENCES

- [1] L. O. Chua, "Memristor-the missing circuit element," *IEEE Trans. Circuit Theory*, vol. CT-18, no.5, pp. 507-519, 1971.
- [2] D. B. Strukov, G. S. Snider, D. R. Stewart, and R. S. Williams, "The missing memristor found," *Nature*, vol. 453, pp. 80-83, 2008.
- [3] J. J. Yang, M. D. Pickett, X. Li, D. A. A. Ohlberg, D. R. Stewart, and R. S. Williams, "Memristive switching mechanism for metal/oxide/metal nanodevices," *Nature Nanotechnol.*, vol. 3, pp. 429-433, Jul. 2008.
- [4] H. Mostafa, M. Anis, and M. Elmasry, "A design-oriented soft error rate variation model accounting for both die-to-die and within-die variations in submicrometer CMOS SRAM cells," *IEEE Trans. Circuits Syst. I, Reg. Papers*, vol. 57, no. 6, pp. 1298-1311, Jun. 2010.
- [5] Y. Ho, G. M. Huang, and P. Li, "Dynamical Properties and Design Analysis for Nonvolatile Memristor Memories," *IEEE Trans. Circuits Syst. I, Reg. Papers*, vol. 58, no. 4, pp. 724-734, April. 2011.
- [6] B. Mouttet, "The mythology of the memristor," in *ISCAS, 2010* [Online]. Available: <http://www.slideshare.net/blaisemouttet/mythical-memristor>
- [7] M. D. Ventra, Y. V. Pershin and L. O. Chua, "Circuit Elements with Memory: Memristors, Memcapacitors and Meminductors," *Proc. IEEE*, vol.97, no. 10, pp. 1717-1724, Oct. 2009.
- [8] B. Mouttet, "An introduction to Memimpedance and Memadmittance System Analysis," 2009 [Online]. Available: <http://knol.google.com/k/an-introduction-to-memadmittance-systems-analysis#>
- [9] M. D. Ventra, Y. V. Pershin and L. O. Chua, "Putting Memory Into Circuit Elements: Memristors, Memcapacitors and Meminductors," *Proc. IEEE*, vol.97, no. 10, pp. 1717-1724, Oct. 2009.
- [10] L. O. Chua and S. M. Kang, "Memristive devices and systems," *Proc. IEEE*, vol. 64, pp. 209-223, 1976.
- [11] "Memristor," Wikipedia [Online]. Available: <http://en.wikipedia.org/wiki/Memristor>