

# Fatigue Life Consumption for Turbine Blades-Vanes Accelerated by Erosion-Contour Modification

Julio C. Gómez-Mancilla, Luis M. Palacios-Pineda and Yunuén López-Grijalba

**Abstract**—A new mechanism responsible for structural life consumption due to resonant fatigue in turbine blades, or vanes, is presented and explained. A rotating blade or vane in a gas turbine can change its contour due to erosion and/or material build up, in any of these instances, the surface pressure distribution occurring on the suction and pressure sides of blades-vanes can suffer substantial modification of their pressure and temperatures envelopes and flow characteristics. Meanwhile, the relative rotation between the blade and duct vane while the pressurized gas flows and the consequent wake crossings, will induce a fluctuating thrust force or lift that will excite the blade.

An actual totally used up set of vane-blade components in a HP turbine power stage in a gas turbine is analyzed. The blade suffered some material erosion mostly at the trailing edge provoking a peculiar surface pressure envelope which evolved as the relative position between the vane and the blade passed in front of each other.

Interestingly preliminary modal analysis for this eroded blade indicates several natural frequencies within the aeromechanic power spectrum, moreover, the highest frequency component is 94% of one natural frequency indicating near resonant condition.

Independently of other simultaneously occurring fatigue cycles (such as thermal, centrifugal stresses).

**Keywords**—Aeromechanic induced vibration, potential flow interaction, turbine unsteady flow, rotor/stator interaction, turbine vane-blade aerodynamic interaction, airfoil clocking

## I. INTRODUCTION

**G**AS turbine efficiency is directly related to high temperature operation. Combined thermodynamic cycles in power generation plants are increasingly common because of significant better efficiency and less contaminant emissions, with environment protection included. Therefore, research and evaluation of gas turbine key components allow ensuring structural integrity and a reliable operation in power generation plants. Rotating blade failure is a recurring failure root causes in gas turbines. These components are subjected to dynamic loads (both, structural and thermal) during the operation cycle and also to centrifugal forces. The blade should stand out to excitation produced by aerodynamic instabilities, among others factors. Interactions between stator and rotor components affect the unsteady pressure field as well as the aerodynamic performance. These interactions include shock and pressure waves that propagate from the

originating blade to downstream components and it has been proven that these interactions can be adequately predicted by computed calculations [1]. According to some recent works [2] the wake flow in turbomachinery together with the inherent unsteadiness caused by interaction between rotor and stator has a significant impact on stage efficiency and performance. Wakes generated by stator rows travel downstream and interact with the succeeding rotor blades affecting pressure distribution, heat transfer and boundary layer transition. The particular problem of the influence of the blade passing effects on the vortex shedding frequency in turbines has received major attention [3]. Important to mention that when stator blades became transonic, pronounced phase locking effects between the rotor passing and the vortex shedding become more evident [2]. Pressure and unsteady heat transfer coefficients are mainly driven by potential and shock interactions between the rows, whereas viscous effects play, in some cases, a minor role [4]. Recently the rotor/stator interaction of transonic turbine stages has been of particular interest recently because of the additional time average losses and unsteady interactions caused by the trailing edge shock systems that exist at supersonic exit conditions. Accurate prediction of flow field on the vane under cyclic operational condition is a major challenge on gas turbine design. Vane crack generations in various zones are due to fluctuations of high temperatures and stress during long periods of time [5]. Hence, in order to bring potential solutions to vane excessive wear and life consumption it is fundamental to locate those hot and stressed points. There exists a whole field covering all related to coatings used to avoid superficial failure, to allow higher operational temperatures and to extend the vane lifetime [19]. This article presents results from a numerical simulation of flow through a first-stage, high-pressure turbine from a 28 MW aeroderivative gas turbine for power generation. Additionally, a mechanism responsible for accelerated life consumption due to potential resonant fatigue in turbine blades, or vanes, is presented and explained. There are two main emphases. Firstly, efforts were made to enhance precise computational calculation that allows estimating the effects produced by the stator/rotor interaction on the pressure envelop. Secondly, the dynamic effects on the blade tangential force on the first stage rotor blade are carefully studied since the aeromechanical forces are capable of exciting resonant response.

## II. METHODOLOGY

Briefly described the proposed methodology encompasses

J. C. Gómez M. is with the Instituto Politécnico Nacional, México, D. F. 07738 México (phone: +52 (55) 5729 6000 x 54737; fax: +52 (55) 5729 6000 x 54588; e-mail: gomezancilla@gmail.com).

L. M. Palacios P. and Y. López G., are with Instituto Tecnológico de Pachuca, Pachuca, Hgo. 42083 México. (phone: +52 (771) 711 3140 x 131,139; e-mail: lmpalacios73@prodigy.net.mx)

careful measurement for the stage components since modification of the original airfoil contours can have a strong influence on the analysis results and conclusions. Next comes the aero-thermodynamic analysis using adequate boundary conditions for a whole gas path and considering the several occurring power stages and as much as possible number of vane/blades, if it is possible taking circumferential quadrant of the stages would yield more precise calculus. Since there will be considerable interaction between stator vanes and rotating blades for each power stage, provisions must be taken to perform the flow analysis of equally separated relative positions between the fixed set of vanes and corresponding rotating blades; calculate at least a circumferential segment equal to the largest pitch distance between duct vanes. Obtaining the resulting pressure and temperature blade envelopes and corresponding thrust forces is next, yielding a pressure force at certain blade spans strategic positions. These unsteady forces will dynamically excite the blade arrangement, therefore extracting the associated frequency power spectrum becomes of capital importance. Next computation of the blade natural frequencies and their corresponding vibratory modes is essential. Having all the previous data and results, we should search for the occurrence of one or more resonance. Important to mention that this methodology focus its attention on one of the causes of the blade life consumption, it does not pretend to incompass all the contributing causes for their life consumption.

### III. ANALYZED CASE

#### A. Nozzle and blade measurement

Vane measurement was performed by means of a Mitutoyo Bright-M C2000 196-444 coordinate measurement machine (CMM). An air ride guide system is used by the CMM and a spherical 3 mm diameter gauge is utilized. The hardware analyzed namely, vane and blade, have 12,000 hours of operating service (with a couple of refurbishing in between).

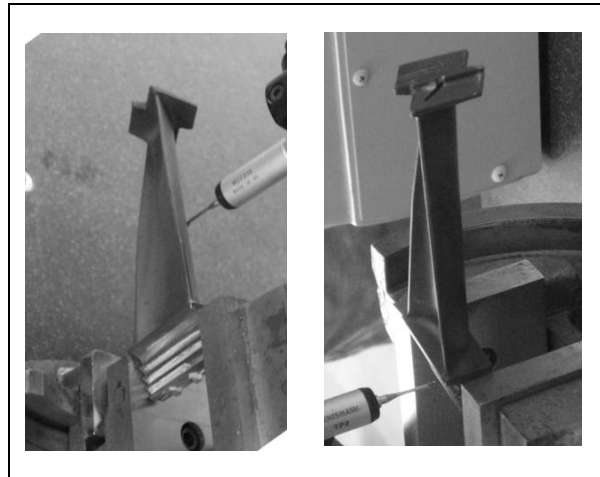
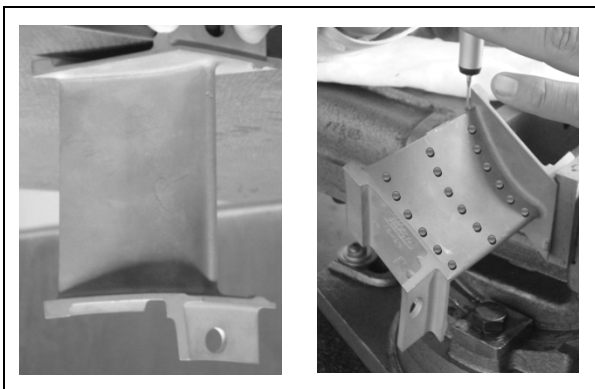

Fig. 1 Actual first stage vane and blade, measurement process. Hardware with 12,000 hour of operation

The vane and blade profile is measured along different heights and output information from the CMM was obtained through a number of spatial coordinates  $x$ ,  $y$  &  $z$  into a text file that was post processed by a Givens [8] rotation matrix (1) as follows:

$$\begin{bmatrix} x' \\ y' \end{bmatrix} = \begin{bmatrix} \cos\beta & \sin\beta \\ -\sin\beta & \cos\beta \end{bmatrix} \begin{bmatrix} x \\ y \end{bmatrix} \quad (1)$$

Throughout this transformation the profile can be rotated to set the correct orientation in the computational model, considering that  $z$  axis must be coincident with the turbine axis. Actual vane and blade in a power stage are shown in figure 1, once the measurement was completed, profiles points were processed and flow channel geometry was derived. Important to mention that the vane angle of attack was measure to  $0^\circ$  and constant vane transversal sections was observed.

#### B. Flow channel set-up

First stage high pressure turbine assembly is presented in figure 2, flow channel is delimited in radial direction by the radii values for tip and root values, meanwhile is enclosed in the circumferential direction it is needed to considered that there are 52 stator vanes and 96 rotors blades. In longitudinal directions the distance between combustor exit and the vane leading edge is considered.

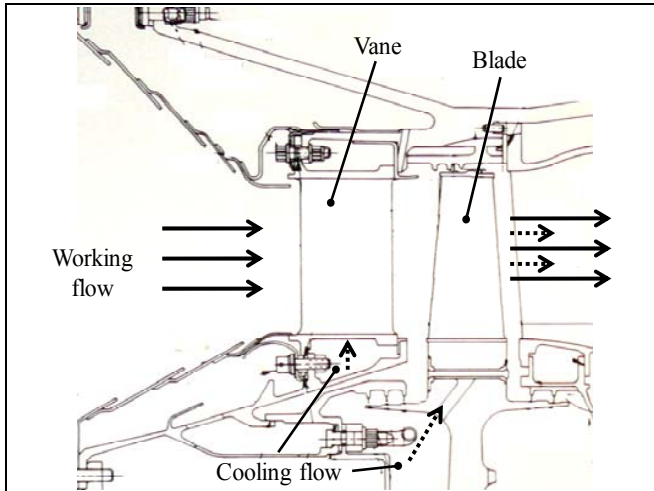

Fig. 2 First stage high pressure turbine assembly and working flow path

Once the profile geometry information and the first stage assembly have been considered, the computational domain is made (figure 3). Cyclic, inlet and outlet boundary conditions are considered and taken from the turbine nominal operational condition.

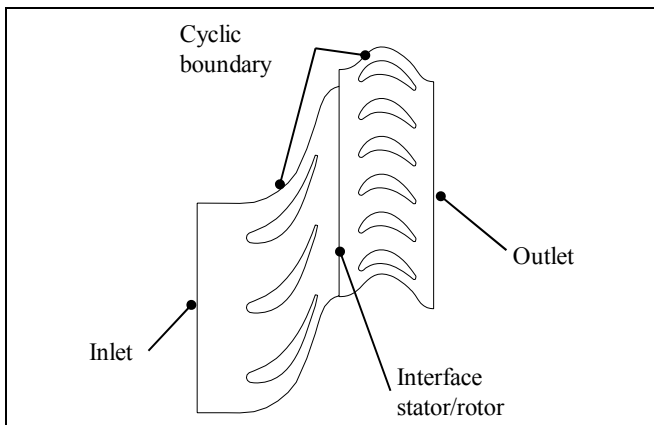

Fig. 3 Computational domain for the first stage

*C. Flow channel meshing*

The two dimensional domain has been meshed, considering the cell size near the wall where the velocity gradients are important.  $Y^+$  values were take into account in order to capture and get an accurate discretization. Table 1 shows the main mesh statistics, a quality mesh is an important factor to get a converged solution.

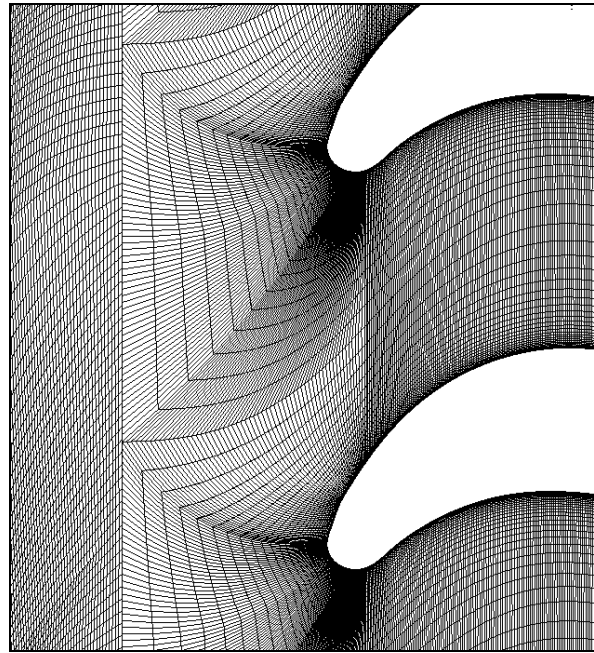

Fig. 4 Flow channel meshing near the blade leading edge

TABLE I  
MESH STATISTICS

Description	Quantity
Vertexes	287,638
Cells	281,100
Minimum Edge Length [m]	$7.82 \times 10^{-4}$

*D. Flow analysis*

Fluid flow governing equations on first stage turbine are continuity (2 y 3) and Navier Stokes (4) equations. Where  $p$  is pressure,  $u$  velocity vector,  $t$  is time,  $\nabla$  divergence operator,  $\mu$  viscosity and  $\rho$  density. Turbulent flow is described by velocity field fluctuations that are originated by the mix of momentum, energy and particle concentration.

$$\nabla \cdot \bar{u} = 0 \tag{2}$$

$$\frac{\partial p}{\partial t} + \frac{\partial}{\partial x_i}(\rho u_i) = 0 \tag{3}$$

$$\frac{\partial}{\partial t}(\rho u_i) + \frac{\partial}{\partial x_j}(\rho u_i u_j) = -\frac{\partial p}{\partial x_i} + \frac{\partial}{\partial x_j} \left[ \mu \left( \frac{\partial u_i}{\partial x_j} + \frac{\partial u_j}{\partial x_i} - \frac{2}{3} \delta_{ij} \frac{\partial u_l}{\partial x_l} \right) \right] + \frac{\partial}{\partial x_j}(-\rho \overline{u'_i u'_j}) \tag{4}$$

Calculation of these variables, given that fact that they are in a minor scale and a high frequency, they represent a very high computational expense. They can be substitute by their

average in time and space. Nevertheless, equations (3) and (4) have additional unknown variables and turbulence models are needed to get these values. In order to select the appropriate turbulence model it has been taken into account the following considerations: the physics of the problem, the approximation level required and the computational resources. The standard  $\kappa$ - $\varepsilon$  turbulence model [6] is a two-equation model in which the solution of two separate transport equations allows the turbulent velocity and length scales to be independently determined. This model has become the workhorse of practical engineering flow calculations. Robustness, economy, and reasonable accuracy for a wide range of turbulent flows explain its popularity in industrial flow and heat transfer simulations [6]. The standard  $\kappa$ - $\varepsilon$  model is a semi-empirical model based on model transport equations for the turbulence kinetic energy ( $\kappa$ ) and its dissipation rate ( $\varepsilon$ ). The model transport equation for  $\kappa$  is derived from the exact equation, while the model transport equation for  $\varepsilon$  was obtained using physical reasoning and bears little resemblance to its mathematically exact counterpart. In the derivation of the  $\kappa$ - $\varepsilon$  model, the assumption is that the flow is fully turbulent, and the effects of molecular viscosity are negligible. The standard  $\kappa$ - $\varepsilon$  model is therefore valid only for fully turbulent flows.

#### A. Boundary conditions

Operational conditions from a 28 MW aero-derivative gas turbine have been derived from equipment manual and field research [7]. Table II shows the boundary conditions applied to the computational domain. The gas turbine compressor has a 13.6 to 1 compression ratio; meanwhile the stage temperature drop is about 181 K.

TABLE II  
BOUNDARY CONDITIONS

Variable	Inlet	Outlet
Static Pressure	1.43 MPa	1.02 MPa
Temperature	1316 K	1135 K
Lineal velocity	256.4325 m/s	--

#### IV. RESULTS

Several vane/blade relative positions have been calculated in order to derive the blade tangential force fluctuation, relative positions for the maximum and minimum blade

tangential force were obtained. The pressure distributions on the blade profile for maximum and minimum tangential blade force are illustrated in figure 5. It has been found that in some cases these pressure envelopes can change up to 20% [12], in this case has been found a variation of up to 40%. Pressure field contour plot is shown in figure 7b, it can be noticed a greater pressure fluctuation on the monitored blade for the extreme positions. Figures 7c and 7d show the contour plots for Mach number and Entropy.

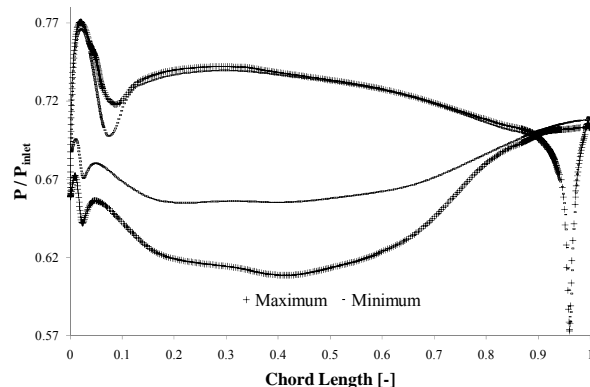

Fig. 5 Rotor blade midspan pressure envelope for maximum and minimum tangential force

Figure 6 shows the rotor blade tangential force time history, this force is per length unit, the studied blade has 0.103m height; and the tangential force spectra is illustrated in figure 8.

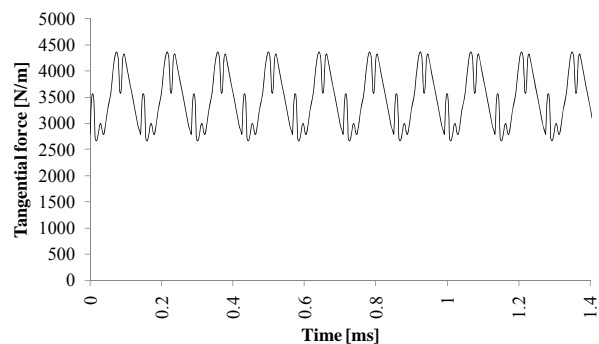

Fig. 6 Rotor blade midspan tangential force fluctuation

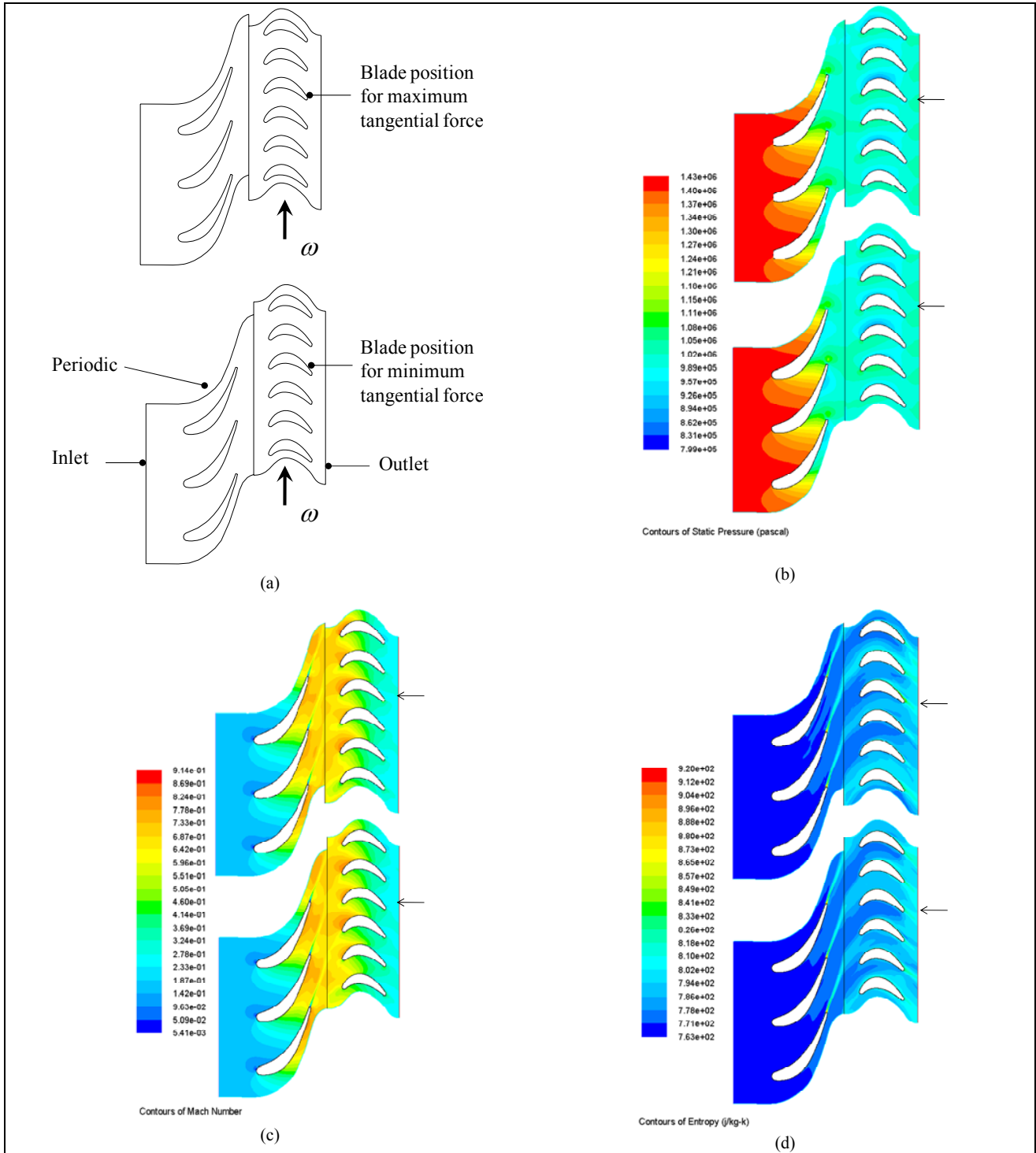

Fig. 7 (a) First stage computational domain, the rotor blade positions for maximum and minimum tangential force are shown. Furthermore, boundary conditions locations are pointed out. (b) Static pressure [Pa] contours for both stator-rotor relative positions, maximum and minimum tangential force. (c) Mach number contours for the complete stage and both extreme positions

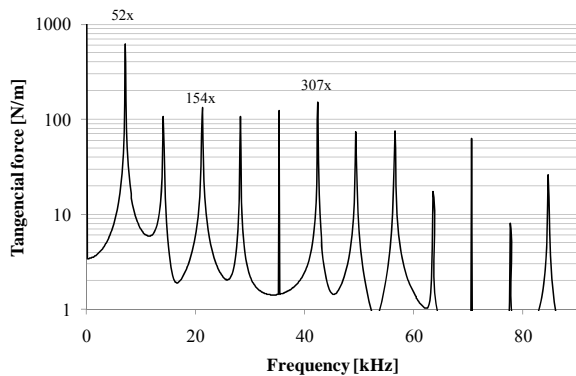

Fig. 8 Rotor blade tangential force spectrum. The main amplitudes are at 52x (7029 Hz), 307x (42,315 Hz) and 154x (21,226 Hz)

The dynamical model for the rotor blade is depicted in figure 9, it can be seen the mounting stiffness and the way the tangential forces are acting on the blade.

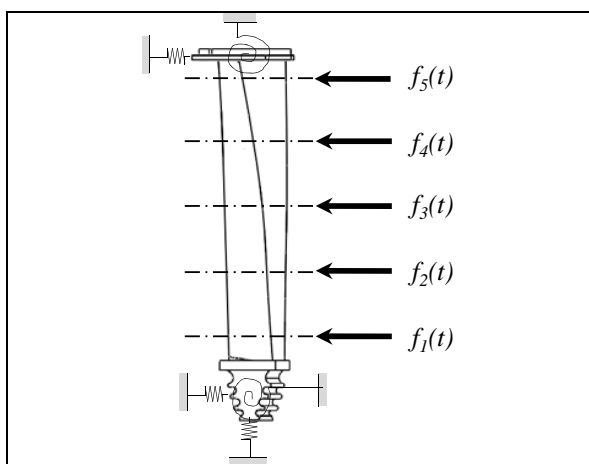

Fig. 9 Rotor blade tangential forces scheme

Table III illustrates the natural frequencies for the rotor blade, obtained from the corresponding blade structural analysis.

TABLE III  
BLADE FIRST TEN NATURAL FREQUENCIES

Mode	Frequency [Hz]	Mode	Frequency [Hz]
1	929	6	9464
2	2347	7	10998
3	3376	8	11847
4	4587	9	12593
5	7420	10	13109

## V. CONCLUSIONS

An innovative methodology for evaluating the life consumption HP gas turbine blades, for subsonic flow, where no shock waves are generated and merely focusing on considering the potential occurrence for resonance fatigue is proposed and presented. This instance can have a great influence in certain cases where the vane/blades suffer a modification of their airfoil profile. In the present analyzed case, the eroded shape of the blade while passing in front of the vane generated a fluctuating force whose frequency spectrum had frequencies coinciding with one blade natural frequency producing a vibrating resonance which accelerated the fatigue life consumption of the blade. Important to express that in the present analysis the range of excitation frequencies of the power spectrum is much wide slightly more than an order of magnitude between the lowest and the highest frequency component. Due to this wide frequency range, the likelihood of resonance or near resonance conditions in some eroded blades (or blade modified shape by debris build up) sensibly increases. From the pressure envelope it can be seen that the trailing edge is the region where a major pressure profile change exists due to blade erosion, because is where a larger pressure drop takes place (figure 5). In the current analysis a 40% change in tangential force is due mainly because the eroded profile and more interestingly, it causes at least a clear blade resonance that would produced an accelerated life consumption of the blade.

## REFERENCES

- [1] Han, J., Dutta, S., Ekkad, S. "Gas Turbine Heat Transfer and Cooling Technology", Taylor&Francis, New York, NY, 2000.
- [2] Woisetschlager, J., Lang, H., Hampel, B., Gottlich, E. and Heitmeir, F. *Influence of blade passing on the stator wake in a transonic turbine stage investigated by particle image velocimetry and laser vibrometry* Proc. Instn Mech. Engrs Vol. 217 Part A: J. Power and Energy, 2003.
- [3] Sondak, D. L. and Dorney, D. J. *Simulation of vortex shedding in a turbine stage*. J. Turbomach., 1999, 121, 428-435.
- [4] Adami, P. and Martelli, F.. *Three-dimensional unsteady investigation of HP turbine stages*. Proc. IMechE Vol. 220 Part A: J. Power and Energy, 2006.
- [5] Tofighi, M., Ali, S., Rezamahdi, N. "Failure Analysis of Gas Turbine Blades", K.N. Toosi University of Technology, Paper 120, ENG 108, Proceedings of the 2008 LAJC-IJME International Conference, Iran, 2008.
- [6] ANSYS FLUENT 12.0 "Theory Guide"
- [7] Maintenance manual MFT4-CID/LF Vol. 1 y Vol. 2.
- [8] Dennis G. Zill, *Cálculo con Geometría Analítica*, Editorial Iberoamericana, segunda edición.
- [9] Shih, T.-H., Liou, W. W., Shabbir, A., Yang, Z., and Zhu, J. *A New  $k-\epsilon$  Eddy-Viscosity Model for High Reynolds Number Turbulent Flows - Model Development and Validation*. Computers Fluids, 24(3):227-238, 1995.
- [10] Fern Engineering, Inc., "Gas Turbine and Combined - Cycle Capacity Enhancement", TR-102412, Generation & Storage Division, EPRI Project Manager, Palo Alto, California, October, 1993.
- [11] Haldeman, C. W., Mathison, R. M., "Aerodynamic and Heat Flux Measurements in a Single-Stage Fully Cooled Turbine- Part I: Experimental Approach", Journal of Turbomachinery, Vol.130/021015-1, Columbus, OH., April 2008
- [12] Cizmas, Paul and Subramanya, Ravishankar, *Parallel computation of rotor/stator interaction*, Westinghouse Electric Corporation and Pittsburgh Supercomputing Center, internal publication 1996.

- [13] Gómez-Mancilla, J., Sinou(est), Jean-Jacques, Nosov, V. R., Thouverez, F., Zambrano(est), A., “*The influence of crack-imbalance orientation and orbital evolution for an extended cracked jeffcott rotor*”, *COMPTEs-RENDUS Mécanique*, R.C., ISSN: 1631-0721, editorial Elsevier, Vol. 332, 2004, Diciembre 2004, pags. 955-962.
- [14] Machorro-Lopez(est), José M., Adams, Douglas E, Gómez-Mancilla, Julio C., Gul(est), Kamra, *Identification of damaged shafts using active sensing – simulation and experimentation*, *journal of sound and vibration*, Elsevier, Vol. 327, Noviembre 2009, pags. 368–390. ISSN 0022-460X
- [15] Gómez-Mancilla J., García illescas(est), Nosov V., *Detection of steady crack growth on rota-ting shafts*, *Procs. 2nd International Symposium On Control And Stability Of Rotating Machinery, ISCORMA-2*, Gdansk Technologic University y Bently Press. Brg, Gdansk, Polonia, Sept. 2003
- [16] Machorro-López J.M.(est), Adams D.E., Gomez-Mancilla J.C., *Crack detection of shafts in rotating machinery using active sensing with an external excitation on a bearing*, *Proceedings of the American Society of Mechanical Engrs, ASME, SMASIS-08*, ISBN 978-7918-3839-6, copyright 2008 ASME, paper 467, Turf Valley, Ellicott City, EEUU, 28-30 Octubre 2008.
- [17] Adams, D. E., “*Health Monitoring of Structural Materials and Components: Methods with Applications*,” 2007, John Wiley & Sons, Chichester, UK
- [18] Haroon, M. and Adams, D., E., “*Component-Level Damage Evolution Laws for Mechanical Damage Prognosis*,” 2008, American Society of Mechanical Engineering *Journal of Applied Mechanics*, Vol. 74(2), DOI: 10.1115/1.2793137
- [19] Douglas E. Adams, *Health Monitoring of Structural Materials and Components*, Ed. John Wiley & Sons Ltd, USA 2007. ISBN 978-0-470-03313-5