

Study on the Characteristics of the Measurement System for pH Array Sensors

Jung-Chuan Chou, and Wei-Lun Hsia

Abstract—A measurement system for pH array sensors is introduced to increase accuracy, and decrease non-ideal effects successfully. An array readout circuit reads eight potentiometric signals at the same time, and obtains an average value. The deviation value or the extreme value is counteracted and the output voltage is a relatively stable value. The errors of measuring pH buffer solutions are decreased obviously with this measurement system, and the non-ideal effects, drift and hysteresis, are lowered to 1.638mV/hr and 1.118mV, respectively. The efficiency and stability are better than single sensor. The whole sensing characteristics are improved.

Keywords—Array sensors, measurement system, non-ideal effects, pH sensor, readout circuit.

I. INTRODUCTION

SINCE P. Bergveld [1] presented a new structure of ion sensitive field effect transistor (ISFET) in 1970, this structure has been applied in biosensors frequently till now. And J. Van Der Spiegel et al. [2] improved the structure of ISFET as extended gate ion sensitive field effect transistor (EGISFET) in 1983. In this study, we use an improved structure, separative extended gate field effect transistor (SEGFET), which separates the sensitive region from the metal-oxide-semiconductor field effect transistor (MOSFET). This structure protects the MOSFET against acid or alkali solutions, and is fabricated by semiconductor manufacture process. Therefore, the SEGFET has lots of advantages such as small volume, disposable, low cost, and simple structure, etc.

Conventional pH ion selective electrodes (ISEs) are usually based on pH-sensitive membranes fabricated by conductive oxides, instead of noble metals. It is possible to form a well-oxidized homogeneous coating onto a surface of substrate. The first material used as a pH-sensitive dielectric by Bergveld is silicon dioxide (SiO_2) [1]. A. Fog and R. Buck [3] represented a series of metal oxides suited to be the pH-sensitive dielectric such as RuO_2 , PtO_2 , TiO_2 , OsO_2 , IrO_2 , RhO_2 , Ta_2O_5 , and SnO_2 produced from oxidized metal or metal powders. In this study, RuO_2 oxidized metal is used to be the pH-sensitive dielectric [4].

J. C. Chou is with the Graduate School of Electronic Engineering, National Yunlin University of Science and Technology, Douliou, Taiwan 64002, R.O.C. (corresponding author to provide phone: 8865-5342601 ext. 2101; fax: 8865-5321719; e-mail: choujc@yuntech.edu.tw).

W. L. Hsia is with the Graduate School of Optoelectronics, National Yunlin University of Science and Technology, Douliou, Taiwan 64002, R.O.C. (e-mail: g9618733@yuntech.edu.tw).

There are several non-ideal effects during measurement such as drift effect, hysteresis effect, etc. The drift effect limits the accuracy of ISFET with which is used to measure pH value [5]. This behavior is a temporal shift of the output voltage under constant conditions such as temperature, pH value and the concentrations of buffer solutions [6]. The SEGFET used has the similar H^+ -sensing mechanism to ISFET [7]. The reason of drift behavior is due to hydrated layer upon sensing surface of sensing membrane [8] which increases the surface capacitance of the ion selective electrode and causes the increment of threshold voltage.

Another non-ideal effect is the hysteresis effect. A system with hysteresis exhibits path-dependence and can not predict an accurate output of a system. After changing the pH solutions, the pH ISE which measured the initial solution will obtain a different response voltage. That is, as the order of measurement is $\text{pH}_x \rightarrow \text{pH}_y \rightarrow \text{pH}_x \rightarrow \text{pH}_z \rightarrow \text{pH}_x$, the response values of the first pH_x , the second pH_x , and the third pH_x are different [9]. Many ion-sensitive membranes such as Si_3N_4 , Al_2O_3 , and TaO_5 have high sensitivities closed to the Nernst response [9], but the magnitude is not the critical factor. In some applications, the memory effect is the critical factor.

In this study, a measurement system includes pH array sensors will increase sensitivity and can improve these drawbacks of non-ideal effects.

II. EXPERIMENTAL

A. Reagents and Materials

The commercial phosphate buffer solutions of analytical grade are used as test solutions supplied by Riedel-deHaën Corp. The substrate for the RuO_2 sensing membrane is silicon wafer, and is supported by the National Nano Device Laboratories (NDL). A 2 in.-diameter and 99.99% purity ruthenium metal target is deposited upon silicon wafers as the RuO_2 pH-sensing membrane using the R.F. sputtering. The detailed fabricating process of potentiometric RuO_2 ISE was mentioned from previous literature [4].

B. Voltage-Time Measurement System

The voltage-time (V-T) measurement system includes one array readout circuit, one data acquisition card (Model: NI USB- 6210, National Instrument Corp.), and analysis software (Model: LabVIEW 7.0, National Instrument Corp.) are used to detect the characteristics of the RuO_2 ISE. One RuO_2 pH ISE and one commercial reference electrode (Model: DX200,

Mettler Toledo) are immersed into the different standard pH buffer solutions with a proportional-integral-differential (PID) temperature controller, and placed inside a dark box to eliminate the light-induced influence.

III. RESULTS AND DISCUSSION

A. Array Sensing System

For a biosensor, the yield is a problem and the designed measurement system will decrease the influence of yield. In this study, the structure consists of eight RuO₂ ISEs. This array sensing system is shown in Fig. 1, and gathers eight potential signals at the same time. The adder adds the eight signals, and the divider divides the sum and obtains the average value. This method can save a lot of time without testing each sensor. The output voltage is expressed as follows:

$$V_{out} = \frac{(V_{in1} + V_{in2} + V_{in3} + V_{in4} + V_{in5} + V_{in6} + V_{in7} + V_{in8})}{8}$$

where the average value, V_{out}, can reduce the influence of yield, non-ideal characteristics, and increase the sensitivity. The sensitivities of RuO₂ array sensors at room temperature 25°C are shown in Fig. 2, and the pH response steps are shown in the inset. The sensitivity of array sensors is approximately 56.01mV/pH, which is near Nernst response. Collecting the experiment results and being shown in Table I. From the data of eight single ISEs, the predicted pH value of pH 7 buffer solution by array sensors is 6.98, and error term is 0.02. This method eliminates the measurement deviation of each sensor, and can obtain a stable average value. In experimental results, the measurement deviations of array sensors are smaller than the predicted values. The maximum deviation 0.20 of single sensor is lowered to the minimum deviation 0.008 of array sensors.

This array sensor measurement system lowers the errors of pH 7 measurement obviously and increases the sensitivities. Table I shows that the array sensors system reduces the measurement errors effectively. This method of average value increases the accuracy and the stability of sensors.

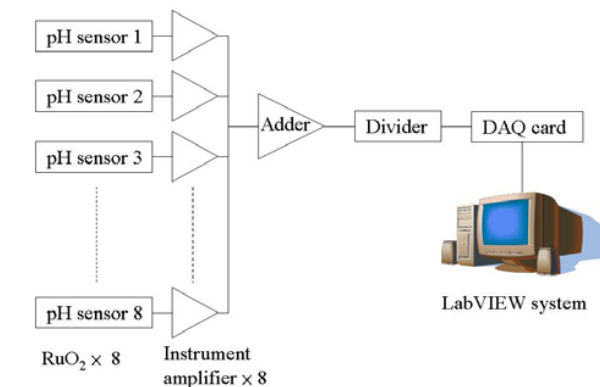

Fig. 1 Schematic diagram of pH array sensing system

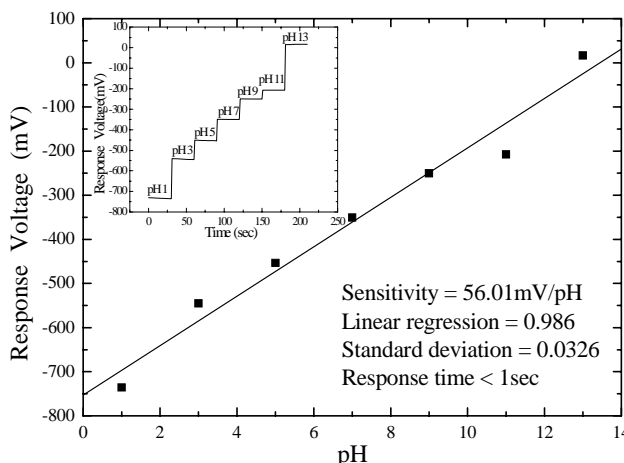

Fig. 2 Sensitivity of RuO₂ array sensors at 25°C

B. Drift effect

When a sensor makes a long-term pH or bio-sensitive measurement, a relatively slow chemical modification is postulated between the surface of electrolyte and sensing membrane of ion-sensitive electrode as a result of exposure in the electrolyte [10]. This reaction changes the dielectric constant of insulator surface, and the overall insulator capacitance, which is determined by a series combination of

TABLE I
 SENSITIVITIES AND pH-MEASURED RANGE OF SINGLE RuO₂ ISE AND RuO₂ ARRAY SENSORS

Single RuO ₂ ISE					
No.	pH range	Sensitivities (mV/pH)	Measured (pH7)	pH meter (pH7)	Errors
Sensor #1	pH1- pH 13	50.25	6.98	7	0.02
Sensor #2	pH1- pH 13	48.02	6.95	7	0.05
Sensor #3	pH1- pH 13	51.84	7.08	7	0.08
Sensor #4	pH1- pH 13	49.51	6.92	7	0.08
Sensor #5	pH1- pH 13	50.65	7.12	7	0.12
Sensor #6	pH1- pH 13	51.26	7.15	7	0.15
Sensor #7	pH1- pH 13	49.86	6.84	7	0.16
Sensor #8	pH1- pH 13	50.53	6.80	7	0.20
RuO ₂ Array Sensors					
Array #1	pH1- pH 13	56.01	6.992	7	0.008
Array #2	pH1- pH 13	55.68	7.010	7	0.010
Array #3	pH1- pH 13	54.32	6.985	7	0.015

equivalent capacitance upon the surface hydrated layer, exhibits a slow and temporal change [10, 11]. Drift behavior exists in the whole measurement process, but doesn't contain the intrinsic reaction of the surface between sensing membrane and solution. Nevertheless, device body, reference electrode, and measurement circuitry are affected greatly. The definition of the drift rate of sensing electrode is the response voltage shifted from 5hr to 12hr. Therefore, the experimental results of RuO₂ ISE using V-T measurement system are shown in Fig. 3. In this study, the drift rate is 1.638mV/hr, and compares with single RuO₂ ISE and previous literatures [12-16] as shown in Table II. Because the designed array sensing system equalizes the output response, the influence of inferior characteristics will be reduced and rise the whole efficiency.

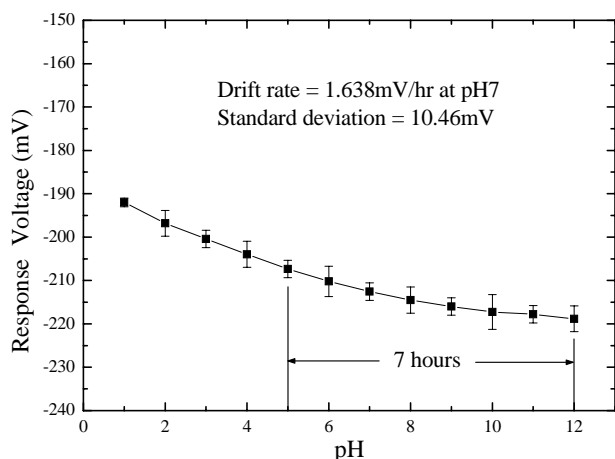

Fig. 3 Drift rate of RuO₂ array sensors in pH7 buffer solution

TABLE II
COMPARISON OF DRIFT RATE IN pH7 BUFFER SOLUTION

No.	Drift rate (mV/hr)
RuO₂ array sensors	
array #1	1.638
array #2	1.857
Single RuO₂ ISE	
sensor #1	3.167
sensor #2	2.153
References	
a-WO ₃ pH sensor [12]	15.7
SnO ₂ pH sensor [13]	6.73
RuN pH sensor [14]	2.15
Ta ₂ O ₅ pH sensor [15]	0.5
a-Si:H pH sensor [16]	6.53

C. Hysteresis Effect

The measurement order of a pH sensor in different pH buffer solutions is repeated for many times to consider the hysteresis effects of these sensing devices. When the loop cycle is pH_x→pH_y→pH_x→pH_z→pH_x, the response values of the same buffer solution will be different [9]. This phenomenon is called hysteresis or memory effect. Bousse et al. [5] depicts that this phenomenon of pH-ISFET is regarded as a delay of the pH

response. According to Nernst formula [5], there is 4% deviation per 1mV of measurement. In this study, the optimal sensitivity is 56.01mV/pH, and the predicted deviation per pH is approximately

$$1pH \times (56.01mV / pH) \times 4\% = 2.2404mV$$

If the sensing device executes measurement *n* times and moves one pH value per step, the permitted error is

$$n \times 1pH \times (56.01mV / pH) \times 4\% = n \times 2.2404mV$$

The array sensors are executed 13 times in this study, and the predicted hysteresis width is

$$13 \times 2.2404mV = 29.1252mV$$

The experimental results obtained the maximum hysteresis width of RuO₂ array sensors system at 1.118mV and 2.05mV in loop cycles pH 7-4-7-10-7 and pH 7-10-7-4-7, respectively, as shown in Fig. 4. The results are lower than the predicted error very much. Table III shows the comparison of the hysteresis width with previous researches [12-14, 17] and the characteristic is better than others.

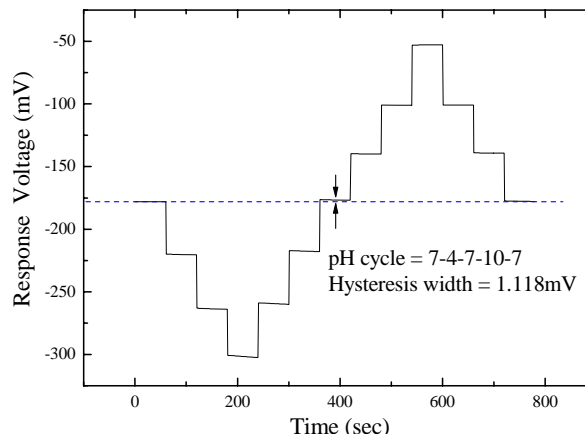

Fig. 4 Hysteresis width of RuO₂ array sensors with pH 7-4-7-10-7 loop cycle

TABLE III
COMPARISON OF HYSTERESIS WIDTH WITH PREVIOUS RESEARCHES

No.	Loop cycle	Hysteresis width (mV)
RuO₂ array sensor		
array #1	pH 7-4-7-10-7	1.118
array #2	pH 7-10-7-4-7	2.05
Single RuO₂ ISE		
sensor #1	pH 7-4-7-10-7	5.48
sensor #2	pH 7-10-7-4-7	3.06
References		
a-WO ₃ pH sensor [12]	pH 4-1-4-7-4	12.0
a-WO ₃ pH sensor [12]	pH 4-7-4-1-4	26.0
SnO ₂ pH sensor [13]	pH 4-1-4-7-4	1.3
SnO ₂ pH sensor [13]	pH 5-1-5-9-5	3.74
RuN pH sensor [14]	pH 7-4-7-10-7	12.7
RuN pH sensor [14]	pH 7-10-7-4-7	9.1
TiN pH sensor [17]	pH 7-4-7-10-7	0.5

IV. CONCLUSION

The pH sensor used in this study is manufactured by semiconductor process, and the advantages are low cost, small volume, portable, etc. But the yield is a problem. This measurement system can save a lot of time without testing each sensor. Hence, this measurement system for array sensors can measure eight electrodes at the same time, and obtains an average response. It not only reduces the non-ideal effects, but also increases the sensitivity and stability. In the experimental results, the drift rate with array measurement system is down to 1.638mV/hr, and smaller than single sensor. The hysteresis width is down to 1.118mV, and smaller than single sensor. The measurement error is decreased and the accuracy is improved. Therefore, the measurement system is excellent for ion measurement.

ACKNOWLEDGMENT

This study is supported by National Science Council, The Republic of China, under the contract NSC 97-2221-E-224-058-MY3 and NSC 96-2628-E-224-008-MY3.

REFERENCES

- [1] P. Bergveld, "Development of an Ion sensitive solid-state device for neurophysiological measurements", *IEEE Transactions on Biomedical Engineering*, BME-17, pp. 70-71, 1970.
- [2] J. Van Der Spiegel, I. Lauks, P. Chan, and D. Babic, "The extended gate chemical sensitive field effect transistor as multi-species microprobe", *Sensors and Actuators B*, vol. 4, pp. 291-298, 1983.
- [3] A. Fog, and R. Buck, "Electronic semiconducting oxides as pH sensors", *Sensors and Actuators*, vol. 5, pp. 137-146, 1984.
- [4] J. C. Chou, C. W. Chen, and P. L. Chou, "Fabrication of ruthenium oxide thin film and response characteristic for hydrogen ion," *Proceedings for Annual Meeting of Physical Society of The Republic of China*, vol. 29, PB-23, p. 256, 2007.
- [5] L. Bousse, H. H. Van Den Vlekkert, and N. F. De Rooij, "Hysteresis in Al₂O₃-gate ISFETs", *Sensors and Actuators B*, vol. 2, pp. 181-183, 1990.
- [6] P. Hein, and P. Egger, "Drift behaviour of ISFETs with Si₃N₄-SiO₂ Gate Insulator", *Sensors and Actuators B*, vol. 13, pp. 655-656, 1993.
- [7] L. T. Yin, J. C. Chou, W. Y. Chung, T. P. Sun, and S. K. Hsiung, "Separate structure extended gate H⁺-Ion sensitive field effect transistor on a glass substrate", *Sensors and Actuators B*, vol. 71, pp.106-111, 2000.
- [8] Z. Yule, Z. Shouan, and L. Tao, "Drift characteristic of pH-ISFET output", *Chinese Journal of Semiconductors*, vol. 12, no. 15, pp. 838-843, 1994.
- [9] L. Bousse, S. Mostarshed, B. Van Der Schoot, and N. F. De Rooij, "Comparison of the hysteresis of Ta₂O₅ and Si₃N₄ pH-sensing insulators", *Sensors and Actuators B*, vol. 17, pp. 157-164, 1994.
- [10] S. Jamasb, S. D. Collins, and R. L. Smith, "A physical model for drift in pH ISFETs", *Sensors and Actuators B*, vol. 49, no. 1/2, pp. 146-155, 1998.
- [11] S. Jamasb, S. D. Collins, and R. L. Smith, "A physical model for threshold voltage instability in Si₃N₄-Gate H⁺-sensitive FET's (pH ISFET's)", *IEEE Transactions on Electron Devices*, vol. 45, no. 6, pp. 1239-1245, 1998.
- [12] J. L. Chiang, S. S. Jan, J. C. Chou, and Y. C. Chen, "Study on the temperature effect, hysteresis and drift of pH-ISFET devices based on amorphous tungsten oxide", *Sensors and Actuators B*, vol. 76, pp. 624-628, 2001.
- [13] J. C. Chou, and Y. F. Wang, "Preparation and study on the drift and hysteresis properties of the tin oxide gate ISFET by the sol-gel method", *Sensors and Actuators B*, vol. 86, pp. 58-62, 2002.
- [14] Y. H. Liao, and J. C. Chou, "Study on the nonideal characteristics of the extended gate field effect transistor based on the ruthenium nitride sensing membrane", *Proceedings of the 3rd Asia-Pacific Conference of the Transducers and Micro-Nano Technology*, Singapore, 4 pages (disk), 2006.
- [15] T. Matsuo, and M. Esashi, "Method of ISFET fabrication", *Sensors and Actuators*, vol. 1, pp. 77-96, 1981.
- [16] J. C. Chou, and C. N. Hsiao, "Drift behavior of ISFETs with a-Si:H-SiO₂ gate insulator", *Materials Chemistry and Physics*, vol. 63, pp. 270-273, 2000.
- [17] Y. L. Chin, J. C. Chou, Z. C. Lei, T. P. Sun, W. Y. Chung, and S. K. Hsiung, "Titanium nitride membrane application to extended gate field effect transistor pH sensor using VLSI technology", *Japanese Journal of Applied Physics*, vol. 40, pp. 6135-6311, 2001.

Jung-Chuan Chou was born in Tainan, Taiwan, Republic of China, on July 13, 1954. He received the B.S. degree in physics from Kaohsiung Normal College, Kaohsiung, Taiwan, in 1976; the M.S. degree in applied physics from Chung Yuan Christian University, Chung-Li, Taiwan, in 1979; and the Ph.D degree in electronics from National Chiao Tung University, Hsinchu, Taiwan, in 1988. He taught at Chung Yuan Christian University from 1979 to 1991. Since 1991 he has worked as an associate professor in the Department of Electronic Engineering at the National Yunlin University of Science and Technology. From 1997 to 2002 he was Dean, office of Technology Cooperation at the National Yunlin University of Science and Technology. And since 2002, he has been Secretary-General at the National Yunlin University of Science and Technology. His research interests are in the areas of amorphous materials and devices, electrographic photoreceptor materials and devices, electronic materials and devices, sensor devices, and science education.

Wei-Lun Hsia was born in Nantou, Taiwan, Republic of China, on April 29, 1983. He received the B.S. degree in the Department of Electrical Engineering at the Chung-Hua University, Hsinchu, Taiwan, in 2007. At the present, he is working toward the Master's degree in the Graduate School of Optoelectronics at the National Yunlin University of Science and Technology. His research interests are semiconductor devices, chemical sensors and their applications.