

Design, Fabrication and Evaluation of MR Damper

A. Ashfak, A. Saheed, K. K. Abdul Rasheed, and J. Abdul Jaleel

Abstract—This paper presents the design, fabrication and evaluation of magneto-rheological damper. Semi-active control devices have received significant attention in recent years because they offer the adaptability of active control devices without requiring the associated large power sources. Magneto-Rheological (MR) dampers are semi-active control devices that use MR fluids to produce controllable dampers. They potentially offer highly reliable operation and can be viewed as fail-safe in that they become passive dampers if the control hardware malfunctions. The advantage of MR dampers over conventional dampers are that they are simple in construction, compromise between high frequency isolation and natural frequency isolation, they offer semi-active control, use very little power, have very quick response, has few moving parts, have a relax tolerances and direct interfacing with electronics. Magneto-Rheological (MR) fluids are Controllable fluids belonging to the class of active materials that have the unique ability to change dynamic yield stress when acted upon by an electric or magnetic field, while maintaining viscosity relatively constant. This property can be utilized in MR damper where the damping force is changed by changing the rheological properties of the fluid magnetically. MR fluids have a dynamic yield stress over Electro-Rheological fluids (ER) and a broader operational temperature range. The objective of this paper was to study the application of an MR damper to vibration control, design the vibration damper using MR fluids, test and evaluate its performance. In this paper the Rheology and the theory behind MR fluids and their use on vibration control were studied. Then a MR vibration damper suitable for vehicle suspension was designed and fabricated using the MR fluid. The MR damper was tested using a dynamic test rig and the results were obtained in the form of force vs velocity and the force vs displacement plots. The results were encouraging and greatly inspire further research on the topic.

Keywords—Magneto-rheological Fluid, MR Damper, Semi-active controller, Electro-rheological fluid.

I. INTRODUCTION

THE passive suspension's drawbacks can be overcome by resorting to one of three techniques, adaptive, semi active or fully active suspension. An adaptive suspension utilizes a passive spring and an adjustable damper with slow response to improve the control of ride and handling. A semi active

suspension is similar, except that the adjustable damper has fast response (less than 10 ms) and the damping force is controlled in real time. A fully active suspension replaces the damper with a hydraulic actuator which can achieve optimum vehicle control, but at high cost. Technology related to vibration control has grown recently and taken on a more interdisciplinary nature. This has been caused by more demanding performance criteria and design specifications of all types of machines and structures. This is particularly true in the case of structural vibration control, robotics and vehicle suspension. Vibration control is becoming increasingly important as the design of mechanisms becomes more and more precise and less tolerant to transient vibration. Active/semi active control provides an important new tool for the control engineer. Many structures, such as automotive vehicles, tall buildings, robotic manipulator arms and flexible spacecraft have already been designed using active/semi-active vibration isolation as part of the total design. In active vibration control (Fig. 2) the damping force can be altered as required and hence we can control the vibration characteristics of the system. The conventionally used active force generator (F-active in Fig. 2) is a very complex hydraulic system and requires a very large control power. Also the system may collapse in case of a failure of the active force generator. To overcome these shortcomings we use semi-active controllers depicted in Fig. 3.

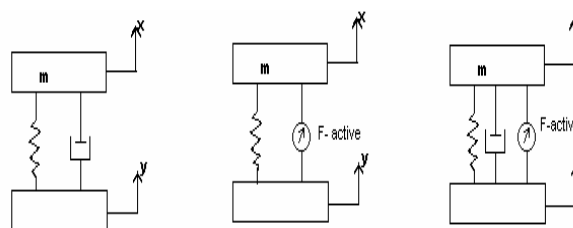

Fig. 1 Passive suspension Fig. 2 Active suspension Fig. 3 Semi-active suspension

Various semi-active dampers are being employed in different vibration isolation systems. Two such dampers are the newly conceived Electro-Rheological (ER) and Magneto-rheological (MR) dampers. The main advantages of these dampers are that they need very less control power, have simple construction, quick response to control signal and very few moving parts.

MR Fluids are non-colloidal suspensions of magnetizable particles that are of the order of tens of 20-50 μm in diameter. MR devices are capable of much higher yield strengths when

A. Ashfak, A. Saheed and K. K. Abdul Rasheed are with Mechanical Engineering department, TKM College of Engineering, Kollam - 05, University of Kerala, India (e-mail: ashfaktkm@yahoo.com, saheedtkm@yahoo.com, kkrashedtkm@yahoo.com).

J. Abdul Jaleel is with Electrical & Electronics Engineering department, TKM College of Engineering, Kollam-05, University of Kerala, India (e-mail: contact@drabduljaleel.com, phone: +91 474 2708713, +919446318713, Fax: +91474271023).

activated. The main difference between Ferro fluids and MR fluids is the size of the polarizable particles. In Ferro fluids, these particles are an order of magnitude smaller than MR Fluids that is they are 1-2 μm , in contrast to 20-50 μm for MR fluids. MR Fluid is composed of oil, usually mineral or silicon based, and varying percentages of ferrous particles that have been coated with an anti-coagulant material. Engineering notes by Lord Corporation [1] have reported that when unactivated, MR Fluid displays Newtonian-like behavior when exposed to a magnetic field, the ferrous particles that are dispersed through out the fluid form magnetic dipoles. These magnetic dipoles align themselves along lines of magnetic flux, as shown in Fig. 4.

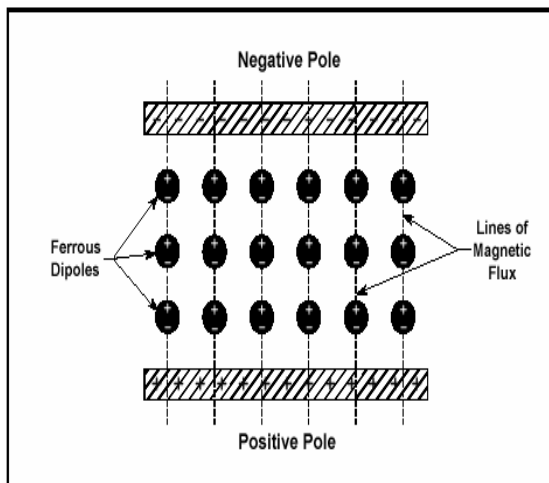

Fig. 4 Dipole alignments of ferrous particles

On a larger scale, this reordering of ferrous dipole particles can be visualized as a very large number of microscopic beads that are threaded onto a very thin string as is shown in Fig. 5. One can picture this thin string stretching from one magnetic pole to the other and perpendicular to each paramagnetic pole surface.

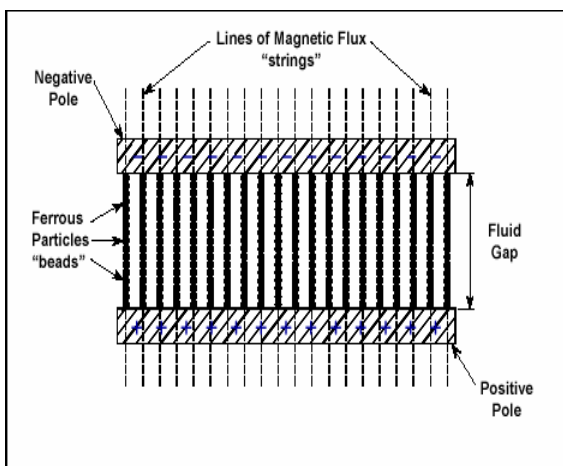

Fig. 5 String and beads analogy of activated MR fluid

In this analogy, the spherical beads represent iron particles and each string represents a single flux line. One can picture many of these strings of beads placed closely together much like the bristles of a toothbrush. Once aligned in this fashion, the ferrous particles resist being moved out of their respective flux lines and act as a barrier to fluid flow. Typically, MR fluids can be used in three different ways, all of which can be applied to MR damper design depending on the damper's intended use. These modes of operation are referred to as squeeze mode, valve mode and shear mode.

II. M. R. DAMPER TYPES

There are three main types of MR dampers. These are the mono tube, the twin tube, and the double-ended MR damper. Of the three types, the mono tube is the most common since it can be installed in any orientation and is compact in size. A mono tube MR damper, shown in Fig.6, has only one reservoir for the MR fluid and an accumulator mechanism to accommodate the change in volume that results from piston rod movement. The accumulator piston provides a barrier between the MR fluid and a compressed gas (usually nitrogen) that is used to accommodate the volume changes that occur when the piston rod enters the housing.

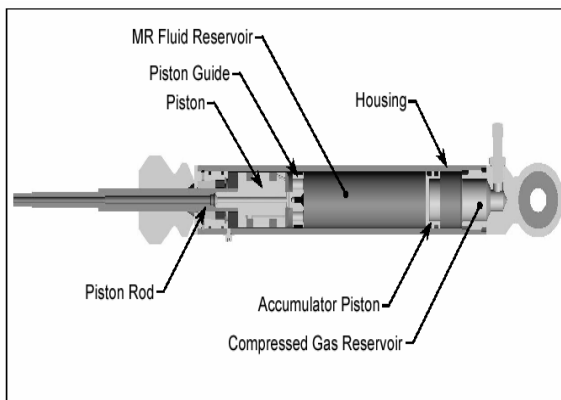

Fig. 6 Monotube MR Damper section view

The twin tube MR damper is one that has two fluid reservoirs, one inside of the other, as shown in Fig. 7. In this configuration, the damper has an inner and outer housing. The inner housing guides the piston rod assembly, in exactly the same manner as in a mono tube damper. The volume enclosed by the inner housing is referred to as the inner reservoir. Likewise, the volume that is defined by the space between the inner housing and the outer housing is referred to as the outer reservoir. The inner reservoir is filled with MR fluid so that no air pockets exist.

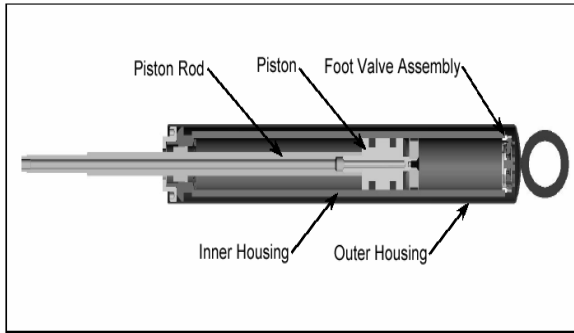

Fig. 7 Twin tube MR damper

To accommodate changes in volume due to piston rod movement, an outer reservoir that is partially filled with MR fluid is used. Therefore, the outer tube in a twin tube damper serves the same purpose as the pneumatic accumulator mechanism in mono tube dampers. In practice, a valve assembly called a “foot valve” is attached to the bottom of the inner housing to regulate the flow of fluid between the two reservoirs. As the piston rod enters the damper, MR fluid flows from the inner reservoir into the outer reservoir through the compression valve, which is part of the foot valve assembly. The amount of fluid that flows from the inner reservoir into the outer reservoir is equal to the volume displaced by the piston rod as it enters the inner housing. As the piston rod is withdrawn from the damper, MR fluid flows from the outer reservoir into the inner reservoir through the return valve, which is also part of the foot valve assembly. The final type of MR damper is called a double-ended damper since a piston rod of equal diameter protrudes from both ends of the damper housing. Fig. 8 shows a section view of a typical double-ended MR damper. Since there is no change in volume as the piston rod moves relative to the damper body, the double-ended damper does not require an accumulator mechanism. Double-ended MR dampers have been used for bicycle applications [1] gun recoil applications [2], commercial applications [3], [4], [5], and for controlling building sway motion caused by wind gusts and earthquakes [6].

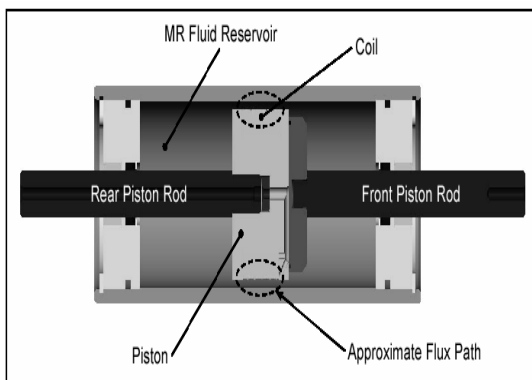

Fig. 8 Double-ended MR damper

III. MR DAMPER MATHEMATICS

MR fluid behaves in two distinct modes: off state and activated state. While Newtonian like behavior is common in the off state, the fluid behaves as a Bingham plastic with variable yield strength when activated. Though the fluid does have the departures from this model, this gives a good reference as to the behavior of the fluid [7], [8].

The shear stress associated with the flow of MR fluid can be predicted by the Bingham equations [9],

$$\tau = \tau_y (B) + \eta \dot{\gamma}, \tau > \tau_y \quad (1)$$

In equation (1), τ is the fluid shear stress, τ_y is the fluid's yield stress at a given magnetic flux density B , η is the plastic viscosity (i.e. viscosity at $B=0$), and $\dot{\gamma}$ is the fluid shear rate. This equation holds for fluid stresses above the field dependent yield stress [9]. However, for fluid stresses below τ_y , the MR fluid behaves as a visco-elastic material:

$$\tau = G \dot{\gamma}, \tau < \tau_y \quad (2)$$

where τ is the fluid shear stress, G is the complex material modulus, and $\dot{\gamma}$ is the fluid shear.

MR dampers generally use the pressure driven flow (valve) mode of the fluid. Pressure driven flow mode has two components to the pressure drop: pressure loss due to viscous drag, and pressure loss due to the field dependent yield stress, as shown in equation (3) [9]

$$\begin{aligned} \Delta P &= \Delta P_n + \Delta P_\tau \\ &= \frac{12\eta QL}{g^3 w} + \frac{c \tau_y L}{g} \end{aligned} \quad (3)$$

In equation (3), ΔP is the total pressure drop, ΔP_n is the viscous pressure loss, ΔP_τ is the field dependent yield stress pressure loss, η is the fluid viscosity, Q is the flow rate, L is the pole length, w is the pole width, g is the fluid gap, and τ_y is the field dependent yield stress. Many of these dimensions are illustrated in Fig. 9. The variable changes from a minimum value of 2 (for $\Delta P_\tau / \Delta P_n < 1$) to a maximum value of 3 (for $\Delta P_\tau / \Delta P_n > 100$).

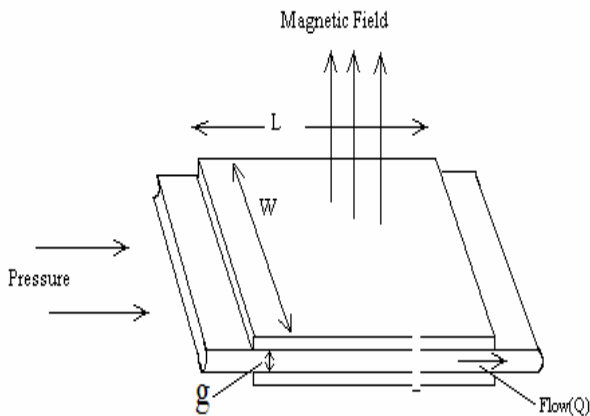

Fig. 9 Flow mode used in MR dampers

The volume of fluid exposed to the magnetic field controls the desired MR effect [9], [10].

Equations (2) can be manipulated to yield:

$$V = k \left(\frac{\eta}{\tau_y^2} \right) \lambda W_m \quad (4)$$

Where k is a constant and λ is the control ratio required to achieve a specified mechanical power, W_m [9].

The equations for the variables in equation (4) are:

$$k = \frac{12}{c^2} \quad (5)$$

$$\lambda = \frac{\Delta P_\tau}{\Delta P_\eta} \quad (6)$$

$$W_m = Q \Delta P_\tau \quad (7)$$

Equation (4) can be further manipulated to provide constraints and aspect ratios for efficient use of MR fluid [9].

$$wg^2 = \frac{12}{c} \left(\frac{\eta}{\tau_y} \right) \lambda Q \quad (8)$$

IV. DESIGN CONFIGURATION

To use the concept of MR fluid damper we need to produce magnetic field in the flow path of the MR fluid. Hence the following configuration was used. As shown in Fig. 7, the MR fluid flows from the right chamber to the left chamber and vice-versa when piston moves to and fro. The magnetic field is applied by using a copper coil wound around the piston body. The leads to the coil are taken out through the hollow piston rod. The configuration is simple and easy to manufacture. The design involves both magnetic

circuit designs along with previously mentioned mechanical design. The design also based upon type of MR fluid used in the damper. Fig. 10 illustrates the conceptual design of the MR damper. Spool of magnet wire, Shown with the vertical hash marks, generate magnetic flux within the steel piston.

The flux in the magnetic circuit flows axially through the piston core of diameter D_c , beneath the winding, radially through the piston poles of length L_p , through a gap of thickness t_g , in which the MR fluid flows, and axially through the cylinder wall of thickness t_w . Our MR damper design involves six different physically dimensioned parameters. They are the diameter of the cylinder bore, D_b ,

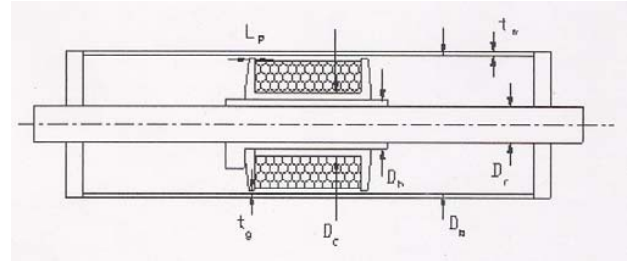

Fig. 10 Design of the MR damper

the diameter of the piston rod, D_p , the thickness of the casing wall, t_w , the diameter of the piston core, D_c , the inside piston diameter, D_h , the pole length, L_p and the thickness of the gap, t_g .

The pressure drop across the piston is

$$\Delta P = c \frac{\tau_y}{t_g} + \frac{12 Q \eta (L_w + 2 L_p)}{\pi (D_p + t_g) t_g^3} \quad (9)$$

The force generated in the device, F , is the pressure drop times the piston cross section area and can be expressed as,

$$F = \Delta P \pi \frac{((D_p + t_g)^2 - D_r^2)}{4} \quad (10)$$

Assuming incompressibility, Q is related to the piston velocity, V_p , by

$$Q = V_p (\pi / 4) (D_p^2 - D_r^2) \quad (11)$$

Our objective is to minimize the time constant of the device and electric power consumption of the device,

$$J = i^2 R + \beta \frac{L}{R} \quad (12)$$

where R is resistance, L is inductance, i is current, β is weighting coefficient and J is objective function.

V. TESTING AND ANALYSIS

The designed damper was tested to check its performance as compared to the ideal behaviour. For this, the test set-up used was as shown in Fig. 11.

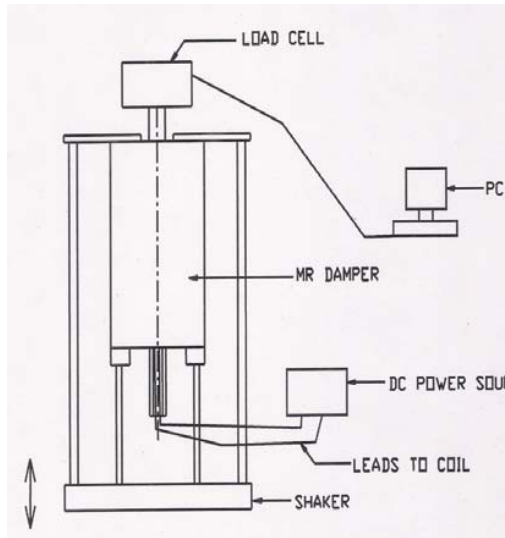

Fig. 11 Dynamic testing machine

The cylinder of the MR damper was clamped to the shaker (vibrator) as shown. The shaker was actuated by a cam arrangement that converted the rotary motion of the motor shaft into linear to and fro motion.

A. Testing Procedure

The damper was tested for a stroke length of 20mm and a frequency of 2Hz. The force experienced in the piston rod, which was prevented from motion, was sensed by a load cell fixed at the top of the set-up as shown. The test was performed for 10 cycles for each current value. The damper was tested for different voltage values (0-4V) across the coil.

VI. TESTING AND ANALYSIS

Fig. 12 shows the variation of force with time at different applied voltage. Fig. 13 shows the equivalent damping coefficients vs. voltage. As the voltage increases the damping force increases for the constant interval of time. Fig. 14 shows the variation of force versus displacement of the damper. Fig. 15 shows the variation of force versus velocity. These plots show that the damping force is very low for zero current and it increases gradually as the current is increased. Also the yield stress part of the damping force dominates the viscous force. This means we have very good control over the damping force, which is necessary for semi-active control. Also the controllable force is not zero at zero current which means the yield stress is never zero.

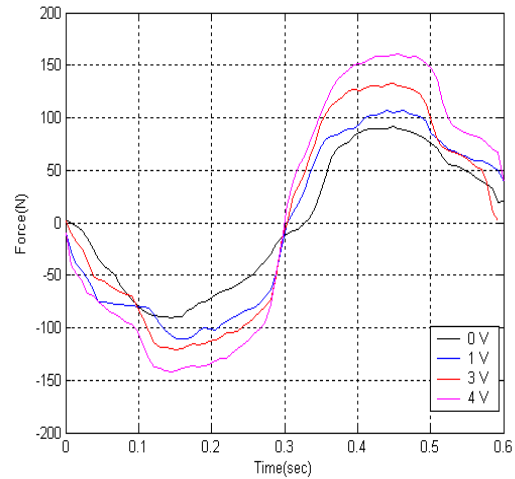

Fig. 12 Force vs. time

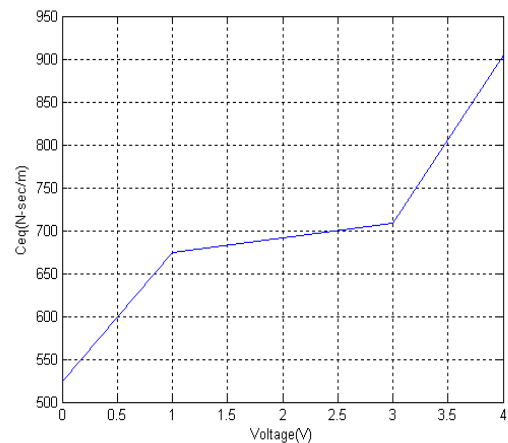

Fig. 13 Equivalent damping coefficients vs. voltage

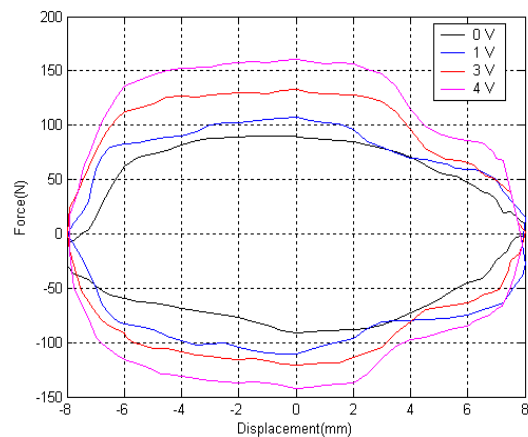

Fig. 14 Force vs. displacement

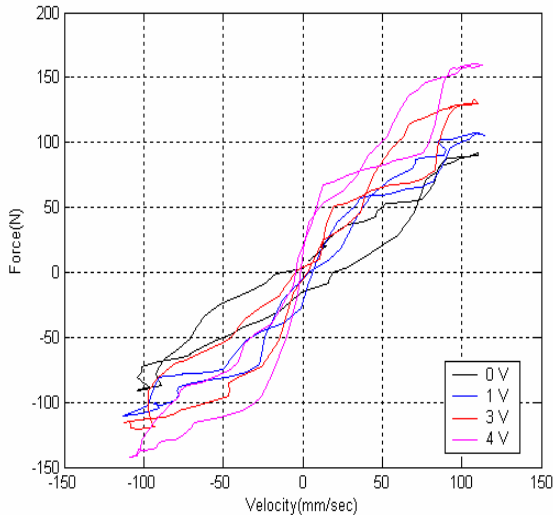

Fig. 15 Force vs. Velocity

VII. CONCLUSION

The aim of the project was to use MR fluids and their use in vibration control. And also an MR damper was to be designed and fabricated. The MR damper was tested and its results were obtained. The study of rheology as such, the theory behind rheological fluids, their properties and their application to vibration control. The design and fabrication of MR damper suited to vehicle suspensions were carried out.

REFERENCES

- [1] Ahmadian, M., (1999) "Design and development of magneto-rheological dampers for bicycle suspensions", American Society of Mechanical Engineers, Dynamic Systems & Control Division Publication, DSC, Vol. 67, pp.737-741
- [2] Ahmadian, M., J. C. Poynor, J. M. Gooch, (1999) "Application of magneto-rheological dampers for controlling shock loading", American Society of Mechanical Engineers, Dynamic Systems & Control Division (Publication) DSC-, Vol.67, pp. 731-735.
- [3] Carlson D,(2001) D. M. Catanzarite and K. A. St. Clair, "Commercial magneto-rheological fluid devices", Lord Corporation.
- [4] Carlson, J. D., W. Matthis, and J. R. Toscano., "Smart prosthetics based on magneto-rheological fluids", SPIE 8 th Annual Symposium on Smart Structures
- [5] "Designing with MR fluids", (1999) Lord Corporation Engineering note, Thomas Lord Research Center, Cary, NC.
- [6] Dyke.S.J., B.F. Spencer Jr., M.K. Sain, and J.D. Carlson, (1996) "Seismic response reduction using magneto-rheological dampers", Proceedings of the IFAC World Congress; San Francisco, CA
- [7] Poyner, C. James (2001), "Innovative designs for magneto-rheological dampers", MS Thesis, Advanced Vehicle Dynamics Lab, Virginia Polytechnic Institute and State University, Blacksburg, VA.
- [8] Seval, G, (2002) "Synthesis and properties of magneto rheological (MR) fluids", PhD. Thesis, University of Pittsburgh.
- [9] Spencer. B. F Jr., S. J. Dyke, M. K. Sain and J. D. Carlson, (1996) "Phenomenological model of a magneto-rheological damper", ASCE Journal of Engineering Mechanics, pp.1-23
- [10] "Vibration and Seat Design", (2001) Lord Corporation white paper, Thomas Lord Research Center, Cary, NC.

APPENDIX

EXPERIMENTAL SETUP

