

# Comprehensive Study on the Linear Hydrodynamic Analysis of a Truss Spar in Random Waves

Roosbeh Mansouri, Hassan Hadidi

**Abstract**—Truss spars are used for oil exploitation in deep and ultra-deep water if storage crude oil is not needed. The linear hydrodynamic analysis of truss spar in random sea wave load is necessary for determining the behaviour of truss spar. This understanding is not only important for design of the mooring lines, but also for optimising the truss spar design. In this paper linear hydrodynamic analysis of truss spar is carried out in frequency domain. The hydrodynamic forces are calculated using the modified Morison equation and diffraction theory. Added mass and drag coefficients of truss section computed by transmission matrix and normal acceleration and velocity component acting on each element and for hull section computed by strip theory. The stiffness properties of the truss spar can be separated into two components; hydrostatic stiffness and mooring line stiffness. Then, platform response amplitudes obtained by solved the equation of motion. This equation is non-linear due to viscous damping term therefore linearised by iteration method [1]. Finally computed RAOs and significant response amplitude and results are compared with experimental data.

**Keywords**—Truss Spar, Hydrodynamic analysis, Wave spectrum, Frequency Domain

## I. INTRODUCTION

**B**Y the discovery of the most main land oil fields nowadays new oil and gas sources are being discovered less than the past, on the other hand the population increase and economics developments in recent decade and more request for oil result in the increase of oil price so we can see oil production in the sea depths become more and more economic. These days advanced countries are attacked to the deeper zones for discovering new sources. Platforms, FPSO, TLP and SPAR are suitable examples for deeper zones.

R. Mansouri is with School of Marine Science and Technology, University of Hormozgan, Bandar Abbas, IRAN. (Corresponding author to provide phone: +98-711-6306016; fax: +98-711-6306016; e-mail: Roosbeh\_sas@yahoo.com).

H. Hadidi is with School of Marine Science and Technology, University of Hormozgan, Bandar Abbas, IRAN. (Corresponding author to provide phone: +98-711-6306016; fax: +98-711-6306016; e-mail: h.hadidi61@gmail.com).

When water depth exceeds from a specific level, spar for its simple shape and structure is one of the most economic choices. Classic spar and truss spar are more prevalent spars. Classic spar is a deep draught, vertical, large diameter cylindrical vessel. The top part of the hull provides the buoyancy and the midsection provides plenty room for oil storage. The lower compartment holds the ballast, which controls the trim for spar. If storage of crude oil is not needed truss spar is used. The cylindrical midsection of the classical spar is replaced with a truss framework and plated horizontal levels. These horizontal steel plates entrap the water in vertical motions and bring the effective vertical mass of the structure up to the same level as a classical spar. Glansville mentioned a number of advantages of the truss spar over the classic spar, such as less steel for construction, simpler and cheaper; less drag area therefore reduced mooring loads, and less drag when towed upright. In marine dynamics, there are two basic approaches to solve the dynamic responses. This can either be done in the frequency domain or via time domain analysis. Frequency domain analysis is performed for the linearised problem so; using an iterative technique may include some non-linear effects. In contrast, time domain analysis utilises the direct numerical integration of the differential equations including all the non-linearities. The results obtained by the frequency domain technique are simpler to interpret and apply for further analysis [1]-[2]. Therefore, the frequency domain technique is preferable as long as the non-linear effects are small. For both cases, the equations of motion are the same, but their formulation and approximation reflect the strengths and limitations of the method used. Also, the non-linear time domain analysis does not necessarily produce better results compared to a simpler frequency domain analysis because of other uncertainties in the interaction problem [2]. The Measurements and calculations showed that truss spars have better dynamic characteristics than same classic spars. Between wind, current and wave, waves are most important factor in exerting excitation loads on spar platforms. Purpose of this paper is estimating wave loads on a specific truss spar and determining its dynamic response to random sea waves. This analysis is necessary to show that if a plan is desirable. The numerical results presented in this paper are compared with the experimental and numerical results reported by Stansberg et al [3], and Downie et al [4]. Details of the model and experimental set-up are given by Downie et al [4]. Nygaard et al [5], and, Stansberg et al [3]. The model was built to 1:100 scale and consist of a conventional spar

shaped upper hull and a lower truss section. It was designed and constructed at the University Of Newcastle, UK. The main dimensions are shown in Fig. 1. In this paper two different types of solid square heave plates were used. The sides of the large plates are 33.5m and the small plates are 29.5m.

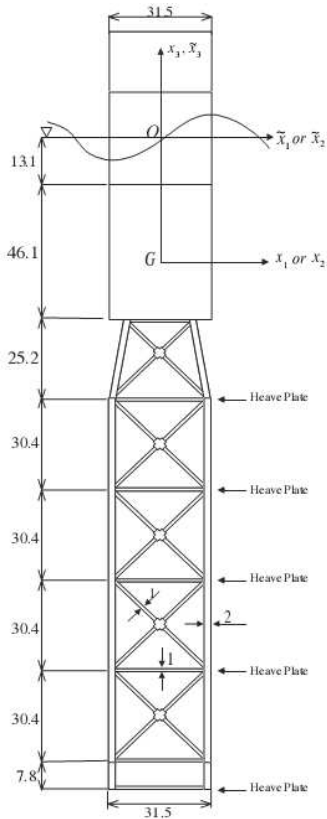

Fig.1 Geometry and Dimensions of the Truss Spar [6]

II. EQUATION OF MOTION

The rigid body motions can be modeled by *Newton's Second Law of Motion*, Which in general is given in the following form:

$$M\ddot{X} = \sum_i F_i \tag{1}$$

For a truss spar, (1) takes the form:

$$(M + m)\ddot{X} + B\dot{X} + KX = F(t) \tag{2}$$

Where  $M$ ,  $m$ ,  $B$  and  $K$  are the matrices of physical mass, added mass, quadratic damping and stiffness respectively,  $X$ ,  $\dot{X}$  and  $\ddot{X}$  are the structural displacement, velocity, and acceleration vector respectively and  $F(t)$  is the excitation force vector. The presence of non-linear damping and restoring forces make (2) non-linear therefore the non-linear damping and restoring stiffness must be linearized. The non-linear damping term is linearized by assuming an effective linear damping which would dissipate the same energy at resonance as the non-linear damping [1]-[7]. Also, for mooring lines one can assume that the restoring mooring force change linearly when given a small change in displacement from steady state position. For computed

matrices of added mass, damping, restoring and excitation force, the truss spar divided into three sub-structures; hull, truss and heave plates. Also, by assuming that there will be no hydrodynamic interaction between the substructures, each substructure can be analysed separately. The wave frequency response analysis is performed by combining two sub problems. First, the loading from the incident waves are calculated when the structure is restraint from moving. Then, the reactive added mass, damping and restoring terms are obtained by oscillating the structure in otherwise calm water. First form called radiation problem and second form called diffraction problem.

III. TRANSMISSION MATRIX AND DIRECT COSINES

In this paper for computed matrices of added mass, damping and excitation forces of truss section used the transmission matrix. By transmission matrix, transfer different parameters from wave reference system  $(x_w, y_w, z_w)$ , and structure reference system  $(X, Y, Z)$  to the member reference system  $(u, v, w)$ . All needful parameters calculated in the member reference system and then transferred into the structure's reference system (Fig. 2).

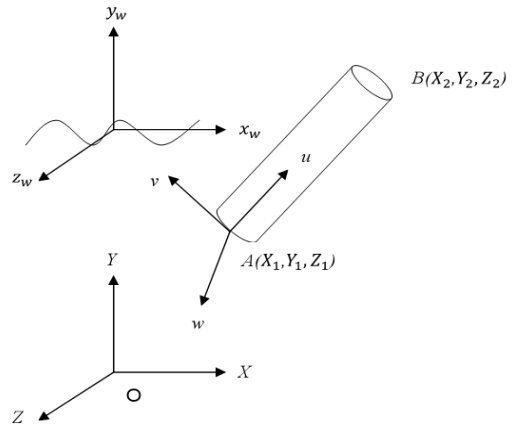

Fig. 2 Reference systems

For obtained the transmission matrix let us consider a Fig. 3. Let  $i, j$  and  $k$  be the unit vector along  $m, n$ - and  $q$ -axis, respectively. Similarly, let  $i', j'$  and  $k'$  be the unit vector along the  $u, v$ - and  $w$ - axis, respectively.

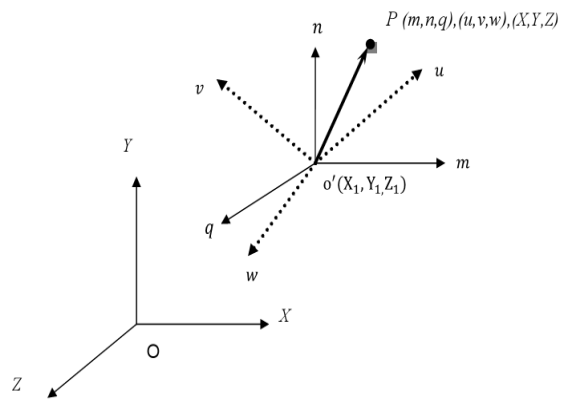

Fig. 3  $(u, v, w)$ ,  $(m, n, q)$  and  $(X, Y, Z)$  coordinates systems

Therefore, the relationship between the  $(u, v, w)$  and  $(m, n, q)$  coordinate systems as follows:

$$\begin{aligned} u &= m\psi_{11} + n\psi_{21} + q\psi_{31} \\ v &= m\psi_{12} + n\psi_{22} + q\psi_{32} \\ w &= m\psi_{13} + n\psi_{23} + q\psi_{33} \end{aligned} \quad (3)$$

Where:

$$\begin{aligned} \psi_{11} &= \vec{i} \cdot \vec{i}' = |\vec{i}'| \cdot |\vec{i}| \cdot \cos \theta = \cos(m, u) \\ \psi_{21} &= \vec{j} \cdot \vec{i}' = |\vec{j}'| \cdot |\vec{i}| \cdot \cos \theta = \cos(n, u) \\ \psi_{31} &= \vec{k} \cdot \vec{i}' = |\vec{k}'| \cdot |\vec{i}| \cdot \cos \theta = \cos(q, u) \\ \psi_{12} &= \vec{i} \cdot \vec{j}' = |\vec{i}'| \cdot |\vec{j}'| \cdot \cos \theta = \cos(m, v) \\ \psi_{22} &= \vec{j} \cdot \vec{j}' = |\vec{j}'| \cdot |\vec{j}'| \cdot \cos \theta = \cos(n, v) \\ \psi_{32} &= \vec{k} \cdot \vec{j}' = |\vec{k}'| \cdot |\vec{j}'| \cdot \cos \theta = \cos(q, v) \\ \psi_{13} &= \vec{i} \cdot \vec{k}' = |\vec{i}'| \cdot |\vec{k}'| \cdot \cos \theta = \cos(m, w) \\ \psi_{23} &= \vec{j} \cdot \vec{k}' = |\vec{j}'| \cdot |\vec{k}'| \cdot \cos \theta = \cos(n, w) \\ \psi_{33} &= \vec{k} \cdot \vec{k}' = |\vec{k}'| \cdot |\vec{k}'| \cdot \cos \theta = \cos(q, w) \end{aligned} \quad (4)$$

Equation (3) in matrix form can be written as follows:

$$\begin{Bmatrix} u \\ v \\ w \end{Bmatrix} = \begin{bmatrix} \psi_{11} & \psi_{21} & \psi_{31} \\ \psi_{12} & \psi_{22} & \psi_{32} \\ \psi_{13} & \psi_{23} & \psi_{33} \end{bmatrix} \begin{Bmatrix} m \\ n \\ q \end{Bmatrix} \quad (5)$$

Also from Fig. 3 we have:

$$\begin{cases} m = X - X_1 \\ n = Y - Y_1 \\ q = Z - Z_1 \end{cases} \quad (6)$$

Therefore the transmission matrix with substituting from (6) into (5) yields,

$$\begin{Bmatrix} u \\ v \\ w \end{Bmatrix} = \begin{bmatrix} \psi_{11} & \psi_{21} & \psi_{31} \\ \psi_{12} & \psi_{22} & \psi_{32} \\ \psi_{13} & \psi_{23} & \psi_{33} \end{bmatrix} \left( \begin{Bmatrix} X \\ Y \\ Z \end{Bmatrix} - \begin{Bmatrix} X_1 \\ Y_1 \\ Z_1 \end{Bmatrix} \right) \quad (7)$$

Where  $(X_1, Y_1, Z_1)^T$  is coordinate of one end of the cylinder and  $\psi_{ij}$ 's ( $i, j = 1, 2, 3$ ) are the direction cosines.

By (7) we can transfer different parameters from structure reference system into the member reference system. Now for transfer the parameters from member reference system into the structure reference system we can write:

$$\begin{Bmatrix} X \\ Y \\ Z \end{Bmatrix} = \begin{bmatrix} \psi_{11} & \psi_{21} & \psi_{31} \\ \psi_{12} & \psi_{22} & \psi_{32} \\ \psi_{13} & \psi_{23} & \psi_{33} \end{bmatrix}^{-1} \begin{Bmatrix} u \\ v \\ w \end{Bmatrix} + \begin{Bmatrix} X_1 \\ Y_1 \\ Z_1 \end{Bmatrix} \quad (8)$$

Since, direct cosines matrix is orthogonal, we can say that inverse matrix equal to transpose matrix. Equation (8) therefore may be written as follows:

$$\begin{Bmatrix} X \\ Y \\ Z \end{Bmatrix} = \begin{bmatrix} \psi_{11} & \psi_{12} & \psi_{13} \\ \psi_{21} & \psi_{22} & \psi_{23} \\ \psi_{31} & \psi_{32} & \psi_{33} \end{bmatrix}^T \begin{Bmatrix} u \\ v \\ w \end{Bmatrix} + \begin{Bmatrix} X_1 \\ Y_1 \\ Z_1 \end{Bmatrix} \quad (9)$$

By (9) we can transfer different parameters from member reference system into the structure reference system.

#### IV. CALCULATION OF ADDED MASS COEFFICIENTS

The added mass concept arises from the tendency of a submerged body moving acceleration relative to the surrounding fluid to induce accelerations to the fluid. These fluid accelerations require forces which are exerted by the body through a pressure distribution of the fluid on the body. Since the submerged body, in effect, imparts acceleration to some of the surrounding fluid, this phenomenon can be equated to the body having an added mass of fluid attached to its own physical mass [8]. For computed added mass coefficients, the truss spar divided into three sub-structures; hull, truss and heave plates. The added mass coefficients calculated for each sub-structure then we can simply add the results together to find the added mass coefficients of whole structure. The added mass coefficients are determined from the solution to the radiation problem. In this case, the Truss Spar oscillating in otherwise calm water.

For truss section added mass coefficients computed by transmission matrix and normal acceleration acting on each circular cylinder. The derivation of the generalized added mass matrix for an arbitrarily oriented circular cylinder depends on the assumption that only added mass forces normal to the cylinder axis are significant [8]. The added mass force of circular cylinder with length  $l$  when given normal acceleration  $a_N$  is [8]

$$F_N^A = A_F \cdot l \cdot a_N \quad (10)$$

Where:

$$A_F = C_a \rho \pi r^2 \quad (11)$$

$A_F$ , is the added mass force per unit length of a circular cylinder with radius  $r$  when given unit acceleration.  $C_a$ , is the added mass force coefficient and  $\rho$  is the density of water.

For circular cylinder,  $C_a = 1$ . From (7) we obtain

$$\begin{aligned} \ddot{u} &= \psi_{11} \ddot{X} + \psi_{21} \ddot{Y} + \psi_{31} \ddot{Z} \\ \ddot{v} &= \psi_{12} \ddot{X} + \psi_{22} \ddot{Y} + \psi_{32} \ddot{Z} \\ \ddot{w} &= \psi_{13} \ddot{X} + \psi_{23} \ddot{Y} + \psi_{33} \ddot{Z} \end{aligned} \quad (12)$$

Since we assumed that the platform oscillates in the X and Y directions only, therefore,  $\ddot{Z}$  equal to zero. Substituting from (10), (11), (12) into (9) yield

$$\begin{Bmatrix} F_{surge}^{A,T} \\ F_{heave}^{A,T} \\ F_{sway}^{A,T} \end{Bmatrix} = \begin{bmatrix} \psi_{11} & \psi_{21} & \psi_{31} \\ \psi_{12} & \psi_{22} & \psi_{32} \\ \psi_{13} & \psi_{23} & \psi_{33} \end{bmatrix}^T \begin{Bmatrix} A_F l \psi_{11} \ddot{X} + A_F l \psi_{21} \ddot{Y} \\ A_F l \psi_{12} \ddot{X} + A_F l \psi_{22} \ddot{Y} \\ A_F l \psi_{13} \ddot{X} + A_F l \psi_{23} \ddot{Y} \end{Bmatrix} \quad (13)$$

By expansion (13), we obtained the added mass coefficients for the coupled translational motions:

$$\begin{aligned} a_{11}^T &= A_F l (\psi_{12}^2 + \psi_{13}^2) \\ a_{12}^T &= A_F l (\psi_{12} \psi_{22} + \psi_{13} \psi_{23}) \\ a_{21}^T &= A_F l (\psi_{22} \psi_{12} + \psi_{23} \psi_{13}) \\ a_{22}^T &= A_F l (\psi_{22}^2 + \psi_{23}^2) \end{aligned} \quad (14)$$

For computing added mass coefficients,  $a_{31}$ ,  $a_{32}$ , we must first obtain the added mass forces on strip of length  $du$  of the cylinder due to surge and heave motions, these strip forces will contribute to a pitch moment due to the lever arm  $R$  (see Fig.- 4) then, obtain the total pitch moment due to surge and heave accelerations by integrating along the cylinder. Therefore:

$$\begin{aligned} F_{3,1}^{A,T} &= \int_0^l \frac{a_{21}^T}{l} \ddot{X} du \cdot X - \int_0^l \frac{a_{11}^T}{l} \ddot{X} du \cdot Y \\ &= (a_{21}^T X_m - a_{11}^T Y_m) \ddot{X} \end{aligned} \quad (15)$$

Where:

$$X_m = \frac{X_1 + X_2}{2}, \quad Y_m = \frac{Y_1 + Y_2}{2} \quad (16)$$

Therefore, we find the added mass coefficient,  $a_{31}^T$

$$a_{31}^T = a_{21}^T X_m - a_{11}^T Y_m \quad (17)$$

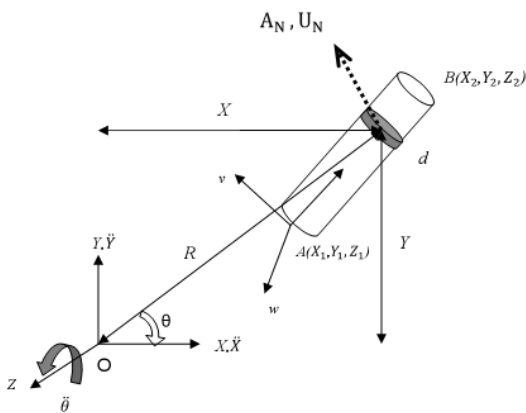

Fig. 4 Definition of velocity, acceleration, moment lever, forces and moments

Similarly,

$$a_{32}^T = a_{22}^T X_m - a_{12}^T Y_m \quad (18)$$

To obtain the added mass force due to pitch acceleration one needs to find the linear acceleration at a point  $(X, Y, Z)$  due to the angular acceleration  $\ddot{\theta}$ . The tangential acceleration is given as:

$$A_N = \ddot{\theta} \cdot R \quad (19)$$

Or as X- and Y components:

$$\begin{aligned} A_X^N &= -A_N \cdot \sin \theta = -\ddot{\theta} \cdot R \cdot \frac{Y}{R} = -\ddot{\theta} \cdot Y \\ A_Y^N &= A_N \cdot \cos \theta = \ddot{\theta} \cdot R \cdot \frac{X}{R} = \ddot{\theta} \cdot X \end{aligned} \quad (20)$$

Then the added mass force on a strip with length  $du$  due to pitch acceleration is given as:

$$\begin{aligned} dF_{1,3}^{A,T} &= \frac{a_{11}^T}{l} \cdot A_X^N \cdot du + \frac{a_{12}^T}{l} \cdot A_Y^N \cdot du \\ dF_{2,3}^{A,T} &= \frac{a_{21}^T}{l} \cdot A_X^N \cdot du + \frac{a_{22}^T}{l} \cdot A_Y^N \cdot du \end{aligned} \quad (21)$$

Now substituting from (20) into (21) and integrating along the cylinder axis the added mass coefficients becomes

$$\begin{aligned} a_{13}^T &= a_{12}^T X_m - a_{11}^T Y_m \\ a_{23}^T &= a_{22}^T X_m - a_{21}^T Y_m \end{aligned} \quad (22)$$

The added mass coefficients for pitch moment due to pitch acceleration are obtained by first transforming the angular acceleration into linear acceleration in X- and Y-direction. These linear accelerations are causing added mass forces on the cylinder, which again results in a pitch moment due to the lever arm  $R$ . The expression for the total moment is given as

$$\begin{aligned} F_{3,3}^{A,T} &= \int_0^l \frac{a_{11}^T}{l} \cdot \ddot{\theta} \cdot Y^2 \cdot du - \int_0^l \frac{a_{12}^T}{l} \cdot \ddot{\theta} \cdot XY \cdot du - \int_0^l \frac{a_{21}^T}{l} \cdot \ddot{\theta} \cdot YX \cdot du \\ &+ \int_0^l \frac{a_{22}^T}{l} \cdot \ddot{\theta} \cdot X^2 \cdot du \end{aligned} \quad (23)$$

Therefore, by integrating along the cylinder axis the added mass coefficient become:

$$a_{33}^T = a_{11}^T Y_n - a_{12}^T XY_n - a_{21}^T XY_n + a_{22}^T X_n \quad (24)$$

Where:

$$X_n = \frac{1}{l} \int_0^l X^2 du = \frac{1}{3} (X_1^2 + X_1 X_2 + X_2^2)$$

$$Y_n = \frac{1}{l} \int_0^l Y^2 du = \frac{1}{3} (Y_1^2 + Y_1 Y_2 + Y_2^2) \quad (25)$$

$$(XY)_n = \frac{1}{l} \int_0^l XY du = \frac{1}{6} (2X_1 Y_1 + X_1 Y_2 + Y_1 X_2 + 2X_2 Y_2)$$

For spar hull, added mass coefficients in surge and pitch can be obtained by using strip theory as described by Faltinsen and Newman [9]-[10]. The added mass coefficient in heave can readily be obtained by using a *flat disk* approach if one assumes the bottom to be far below the free surface. Let us consider a spar hull as shown in the following figure:

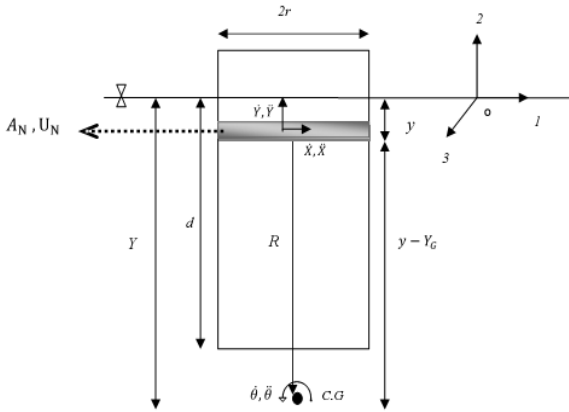

Fig. 5 The spar hull in waves

From strip theory, the added mass force in surge is given as

$$F_{1,1}^{A,H} = \int_{-d}^0 C_a \rho \pi r^2 dy \cdot \ddot{X} = C_a \rho \pi r^2 d \cdot \ddot{X} \quad (26)$$

Therefore

$$a_{11}^H = C_a \rho \pi r^2 d \quad (27)$$

For heave motion, when using the *disc* approach, it becomes [8]

$$a_{22}^H = \frac{1}{2} \frac{8}{3} \rho r^3 \quad (28)$$

Since the water is only accelerated on one side of the *disc*.

The spar hull is vertical and symmetric body, therefore:

$$F_{1,2}^{A,H} = 0 \rightarrow a_{12}^H = 0$$

$$F_{2,1}^{A,H} = 0 \rightarrow a_{21}^H = 0 \quad (29)$$

For computing added mass coefficients,  $a_{31}$ ,  $a_{32}$ , we must first obtain the added mass forces on strip of length  $du$  of the spar hull due to surge and heave motions, these strip forces will contribute to a pitch moment due to the lever arm  $(y - Y_G)$  (see Fig. 5) then, obtain the total pitch moment due

$$F_{3,1}^{A,H} = - \int_{-d}^0 C_a \rho \pi r^2 (y - Y_G) dy \cdot \ddot{X}$$

$$= C_a \rho \pi r^2 d \cdot (Y_G + d/2) \ddot{X} \quad (30)$$

Therefore:

$$a_{31}^H = C_a \rho \pi r^2 d \cdot (Y_G + d/2) \quad (31)$$

Since, spar hull is vertical and symmetric body, therefore:

$$F_{3,2}^{A,H} = 0 \rightarrow a_{32}^H = 0 \quad (32)$$

To obtain the added mass force due to pitch acceleration one needs to find the linear acceleration due to the angular acceleration  $\ddot{\theta}$ . The tangential acceleration is given as

$$A_N = R \cdot \ddot{\theta} \quad (33)$$

Or as X- and Y components:

$$A_X^N = -R \cdot \ddot{\theta}$$

$$A_Y^N = 0 \quad (34)$$

In which,

$$R = (y - Y_G) \quad (35)$$

Then the added mass force on a strip with length  $dy$  due to pitch acceleration is given as

$$dF_{1,3}^{A,H} = \frac{a_{11}^H}{d} \cdot A_X^N \cdot dy$$

$$dF_{2,3}^{A,H} = \frac{a_{22}^H}{d} \cdot A_Y^N \cdot dy \quad (36)$$

Now substituting from (34) and (35) into (36) and integrating along the hull axis the added mass coefficients becomes

$$a_{13}^H = a_{11}^H \cdot (Y_G + d/2)$$

$$a_{23}^H = 0 \quad (37)$$

The added mass force in pitch can be written as

$$dF_{3,3}^{A,H} = -dF_{1,3}^{A,H} \cdot R$$

$$= \frac{a_{11}^H}{d} \cdot \ddot{\theta} \cdot (y - Y_G)^2 \cdot dy \quad (38)$$

Therefore, by integrating along the hull axis the added mass coefficient become:

$$a_{33}^H = C_a \rho \pi r^2 \left[ \frac{d^3}{3} + Y_G^2 d + Y_G d^2 \right]$$

The added mass coefficient for a square heave plates is given as [8]

$$a_{22}^P = C_a^P \rho \frac{\pi}{4} B^3 \quad (40)$$

Where

$$C_a^P \cong 0.58 \quad (41)$$

#### V. CALCULATION OF VISCOUS DAMPING COEFFICIENTS

There are two types of hydrodynamic damping forces that may be experienced on the floating structure which oscillate near or on the free surface [7].

1. Wave damping forces due to the dissipation of energy in the form of surface waves generated by the rigid body motion.

2. Viscous damping forces due to turbulent flow and flow separation in the lee of body.

The viscous damping force is nonlinear. For the truss spar the wave damping is assumed to be insignificant and therefore neglected. The viscous damping force is assumed to be significant for the truss section and steel plates, but also important for the spar hull. This force is proportional to the velocity squared given as [1],

$$F_{i,j}^d = b_{ij} \left| \dot{X}_j \right| \cdot \dot{X}_j \quad (42)$$

Where,  $b_{ij}$ , is the viscous damping coefficient.

The viscous damping coefficients can be obtained in a similar way as for the added mass coefficients, except that the force is now proportional to the velocity squared instead of the acceleration normal to the cylinder axis.

For truss section damping coefficients computed by transmission matrix and normal velocity acting on each circular cylinder. The derivation of the generalized damping matrix for an arbitrarily oriented circular cylinder depends on the assumption that only damping forces normal to the cylinder axis are significant [1]. The drag force of circular cylinder with length  $l$  when given normal velocity  $U_N$  is

$$F_N^D = D_F \cdot l \cdot U_N \cdot |U_N| \quad (43)$$

Where:

$$D_F = \rho C_D r \quad (44)$$

$D_F$ , is the drag force per unit length of a circular cylinder with radius  $r$  when given unit velocity.  $C_D$ , is the drag force coefficient and  $\rho$  is the density of water.

For circular cylinder,  $C_D = 0.6$ . From (7) we obtain

$$\text{Vol:3, No:5, 2009} \\ (39) \quad \dot{U} = \psi_{11} \dot{X} + \psi_{21} \dot{Y}$$

$$\dot{v} = \psi_{12} \dot{X} + \psi_{22} \dot{Y} \quad (45)$$

$$\dot{w} = \psi_{13} \dot{X} + \psi_{23} \dot{Y}$$

Substituting from (43), (44) and (45) into (9) yield

$$\begin{Bmatrix} F_{surge}^{D.T} \\ F_{heave}^{D.T} \\ F_{sway}^{D.T} \end{Bmatrix} = \begin{bmatrix} \psi_{11} & \psi_{21} & \psi_{31} \\ \psi_{12} & \psi_{22} & \psi_{32} \\ \psi_{13} & \psi_{23} & \psi_{33} \end{bmatrix}^T \times \quad (46)$$

$$\begin{Bmatrix} D_F l \psi_{11} |\psi_{11}| \cdot \dot{X} \cdot |\dot{X}| + D_F l \psi_{21} |\psi_{21}| \cdot \dot{Y} \cdot |\dot{Y}| \\ D_F l \psi_{12} |\psi_{12}| \cdot \dot{X} \cdot |\dot{X}| + D_F l \psi_{22} |\psi_{22}| \cdot \dot{Y} \cdot |\dot{Y}| \\ D_F l \psi_{13} |\psi_{13}| \cdot \dot{X} \cdot |\dot{X}| + D_F l \psi_{23} |\psi_{23}| \cdot \dot{Y} \cdot |\dot{Y}| \end{Bmatrix}$$

By expansion (3), we obtained the damping coefficients for the coupled translational motions:

$$\begin{aligned} b_{11}^T &= D_F l (\psi_{12}^2 \cdot |\psi_{12}| + \psi_{13}^2 \cdot |\psi_{13}|) \\ b_{12}^T &= D_F l (\psi_{12} \cdot \psi_{22} \cdot |\psi_{22}| + \psi_{13} \cdot \psi_{23} \cdot |\psi_{23}|) \\ b_{21}^T &= D_F l (\psi_{22} \cdot \psi_{12} \cdot |\psi_{12}| + \psi_{23} \cdot \psi_{13} \cdot |\psi_{13}|) \\ b_{22}^T &= D_F l (\psi_{22}^2 \cdot |\psi_{22}| + \psi_{23}^2 \cdot |\psi_{23}|) \end{aligned} \quad (47)$$

- Computing drag coefficients,  $b_{31}^T, b_{32}^T$ :

$$\begin{aligned} F_{3,1}^{D.T} &= \int_0^l \frac{b_{21}^T}{l} \dot{X} \cdot |\dot{X}| du \cdot X - \int_0^l \frac{b_{11}^T}{l} \dot{X} \cdot |\dot{X}| du \cdot Y \\ &= (b_{21}^T X_m - b_{11}^T Y_m) \dot{X} \cdot |\dot{X}| \end{aligned} \quad (48)$$

Where:

$$X_m = \frac{X_1 + X_2}{2}, \quad Y_m = \frac{Y_1 + Y_2}{2} \quad (49)$$

Therefore, we find the drag coefficient,  $b_{31}^T$ :

$$b_{31}^T = b_{21}^T X_m - b_{11}^T Y_m \quad (50)$$

Similarly,

$$b_{32}^T = b_{22}^T X_m - b_{12}^T Y_m \quad (51)$$

- Computing drag coefficients,  $b_{13}^T, b_{23}^T$ :

The tangential velocity is given as:

$$U_N = \dot{\theta} \cdot R \quad (52)$$

Or as X- and Y components:

$$U_X^N = -U_N \cdot \sin \theta = -\dot{\theta} \cdot R \cdot \frac{Y}{R} = -\dot{\theta} \cdot Y$$

$$U_Y^N = U_N \cdot \cos \theta = \dot{\theta} \cdot R \cdot \frac{X}{R} = \dot{\theta} \cdot X$$

$$(53) \quad I_Y = \frac{1}{l} \int_0^l Y^2 |Y| du$$

Then the added mass force on a strip with length  $du$  due to pitch velocity is given as:

$$dF_{1,3}^{D,T} = \frac{b_{11}^T}{l} \cdot U_X^N \cdot |U_X^N| du + \frac{b_{12}^T}{l} \cdot U_Y^N \cdot |U_Y^N| du$$

$$dF_{2,3}^{D,T} = \frac{b_{21}^T}{l} \cdot U_X^N \cdot |U_X^N| du + \frac{b_{22}^T}{l} \cdot U_Y^N \cdot |U_Y^N| du \quad (54)$$

Now substituting from (53) into (54) and integrating along the cylinder axis the drag coefficients becomes

$$F_{1,3}^{D,T} = -b_{11}^T \dot{\theta} \cdot |\dot{\theta}| \cdot Y_p + b_{12}^T \dot{\theta} \cdot |\dot{\theta}| \cdot X_p$$

$$F_{2,3}^{D,T} = -b_{21}^T \dot{\theta} \cdot |\dot{\theta}| \cdot Y_p + b_{22}^T \dot{\theta} \cdot |\dot{\theta}| \cdot X_p \quad (55)$$

Then,

$$b_{13}^T = b_{12}^T X_p - b_{11}^T Y_p$$

$$b_{23}^T = b_{22}^T X_p - b_{21}^T Y_p \quad (56)$$

Where

$$X_p = \int_0^l X |X| du = \begin{cases} \text{sign}(X_m) (X_1^2 + X_1 X_2 + X_2^2) / 3 & \text{for } X_1 X_2 \geq 0 \\ \text{sign}(X_2) (X_1^3 + X_2^3) / 3(X_2 - X_1) & \text{for } X_1 X_2 < 0 \end{cases}$$

$$Y_p = \int_0^l Y |Y| du = \begin{cases} \text{sign}(Y_m) (Y_1^2 + Y_1 Y_2 + Y_2^2) / 3 & \text{for } Y_1 Y_2 \geq 0 \\ \text{sign}(Y_2) (Y_1^3 + Y_2^3) / 3(Y_2 - Y_1) & \text{for } Y_1 Y_2 < 0 \end{cases} \quad (57)$$

- Computing drag coefficient,  $b_{33}^T$ :

$$dF_{3,3}^{D,T} = -dF_{1,3}^{D,T} \cdot Y + dF_{2,3}^{D,T} \cdot X \quad (58)$$

Now substituting from (54) into (58) and integrating along the cylinder yields,

$$F_{3,3}^{D,T} = \int_0^l \frac{b_{11}^T}{l} \cdot \dot{\theta} |\dot{\theta}| Y^2 |Y| du - \int_0^l \frac{b_{12}^T}{l} \cdot \dot{\theta} |\dot{\theta}| XY |X| du$$

$$- \int_0^l \frac{b_{21}^T}{l} \cdot \dot{\theta} |\dot{\theta}| YX |Y| du + \int_0^l \frac{b_{22}^T}{l} \cdot \dot{\theta} |\dot{\theta}| X^2 |X| du \quad (59)$$

Therefore, by integrating, the added mass coefficient becomes:

$$b_{33}^T = b_{11}^T I_Y - b_{12}^T I_{YX|X|} - b_{21}^T I_{XY|Y|} + b_{22}^T I_X \quad (60)$$

Where:

$$I_Y = \begin{cases} \text{sign}(Y_m) (Y_1^3 + Y_1^2 Y_2 + Y_1 Y_2^2 + Y_2^3) / 4 & \text{for } Y_1 Y_2 \geq 0 \\ \frac{\text{sign}(Y_2) (Y_1^3 + Y_1^2 Y_2 + Y_1 Y_2^2 + Y_2^3)}{4} + \frac{Y_1^4}{2(Y_2 - Y_1)} & \text{for } Y_1 Y_2 < 0 \end{cases} \quad (61)$$

$$I_X = \begin{cases} \frac{1}{l} \int_0^l X^2 |X| du \\ \text{sign}(X_m) (X_1^3 + X_1^2 X_2 + X_1 X_2^2 + X_2^3) / 4 & \text{for } X_1 X_2 \geq 0 \\ \frac{\text{sign}(X_2) (X_1^3 + X_1^2 X_2 + X_1 X_2^2 + X_2^3)}{4} + \frac{X_1^4}{2(X_2 - X_1)} & \text{for } X_1 X_2 < 0 \end{cases} \quad (62)$$

$$I_{YX|X|} = \frac{1}{l} \int_0^l YX |X| du$$

$$= \begin{cases} \frac{Y_2 (X_1^2 + 2X_1 X_2 + 3X_2^2) + Y_1 (3X_1^2 + 2X_1 X_2 + X_2^2)}{12} & \text{for } X_1 X_2 \geq 0 \\ \frac{Y_2 (X_1^2 + 2X_1 X_2 + 3X_2^2) + Y_1 (3X_1^2 + 2X_1 X_2 + X_2^2)}{12} + \frac{X_1^3 (4Y_1 X_2 - 3Y_1 X_1 - Y_2 X_1)}{6(X_2 - X_1)^2} & \text{for } X_1 X_2 < 0 \end{cases} \quad (63)$$

$$I_{XY|Y|} = \frac{1}{l} \int_0^l XY |Y| du$$

$$= \begin{cases} \frac{X_2 (Y_1^2 + 2Y_1 Y_2 + 3Y_2^2) + X_1 (3Y_1^2 + 2Y_1 Y_2 + Y_2^2)}{12} & \text{for } Y_1 Y_2 \geq 0 \\ \frac{X_2 (Y_1^2 + 2Y_1 Y_2 + 3Y_2^2) + X_1 (3Y_1^2 + 2Y_1 Y_2 + Y_2^2)}{12} + \frac{Y_1^3 (4X_1 Y_2 - 3X_1 Y_1 - X_2 Y_1)}{6(Y_2 - Y_1)^2} & \text{for } Y_1 Y_2 < 0 \end{cases} \quad (64)$$

- Spar Hull

The viscous damping force on the spar hull is assumed to be significant in surge and pitch only. The damping coefficient for the spar hull can be obtained by strip theory, as for added mass. From strip theory, the damping force in surge is given as

$$F_{1,1}^{D,H} = \int_{-d}^0 C_D \rho r \dot{X} |\dot{X}| dy = C_D \rho rd \cdot \dot{X} |\dot{X}| \quad (65)$$

Therefore

$$b_{11}^H = C_D \rho rd \quad (66)$$

The spar hull is vertical and symmetric body, therefore:

$$F_{1,2}^{D,H} = 0 \rightarrow b_{12}^H = 0$$

$$F_{2,1}^{D,H} = 0 \rightarrow b_{21}^H = 0$$

$$= -\left(\frac{b_{11}^H}{d} \cdot (-\dot{\theta}(y - Y_G)) - \dot{\theta}(y - Y_G)\right) dy \Big|_{-d}^{d} (y - Y_G) \quad (75)$$

(67)

Therefore, by integrating along the hull axis the added mass coefficient become:

- Computing drag coefficients,  $b_{31}^H, b_{32}^H$ :

$$F_{3,1}^{D,H} = -\int_{-d}^0 C_D \rho r (y - Y_G) dy \cdot \dot{X} \Big|_{\dot{X}}$$

$$= C_D \rho r d \cdot \left(Y_G + \frac{d}{2}\right) \dot{X} \Big|_{\dot{X}}$$

(68)

$$\left\{ \begin{aligned} b_{33}^H &= b_{11}^H \left( \frac{d^3}{4} + Y_G d^2 + \frac{3}{2} Y_G^2 d + Y_G^3 \right) & \text{for } Y_G < -d \\ b_{33}^H &= b_{11}^H \left( \frac{Y_G^4}{2d} + \frac{d^3}{4} + Y_G d^2 + \frac{3}{2} Y_G^2 d + Y_G^3 \right) & \text{for } Y_G \geq -d \end{aligned} \right.$$

(76)

Therefore:

$$b_{31}^H = C_D \rho r d \cdot \left(Y_G + \frac{d}{2}\right) \quad (69)$$

Since, spar hull is vertical and symmetric body, therefore:

$$F_{3,2}^{D,H} = 0 \rightarrow b_{32}^H = 0 \quad (70)$$

- Computing drag coefficients,  $b_{13}^H, b_{23}^H$ :

The tangential velocity is given as:

$$U_N = R \cdot \dot{\theta} \quad (71)$$

Or as X- and Y components:

$$U_X^N = -R \cdot \dot{\theta}$$

$$U_Y^N = 0 \quad (72)$$

Then the drag force on a strip with length  $dy$  due to pitch velocity is given as:

$$dF_{1,3}^{D,H} = \frac{b_{11}^H}{d} \cdot U_X^N \Big|_{U_X^N} \cdot dy$$

$$dF_{2,3}^{D,H} = \frac{b_{22}^H}{d} \cdot U_Y^N \Big|_{U_Y^N} \cdot dy \quad (73)$$

Now substituting from (72) into (73) and integrating along the hull axis the drag coefficients becomes:

$$\left\{ \begin{aligned} b_{13}^H &= b_{11}^H \left( \frac{2Y_G^3}{3d} + \frac{d^2}{3} + Y_G^2 + d \cdot Y_G \right) & \text{for } Y_G < -d \\ b_{13}^H &= -b_{11}^H \left( \frac{d^2}{3} + Y_G^2 + d \cdot Y_G \right) & \text{for } Y_G \geq -d \end{aligned} \right. \quad (74)$$

$$b_{23}^H = 0$$

The drag force in pitch can be written as

$$dF_{3,3}^{D,H} = -dF_{1,3}^{D,H} \cdot R$$

- Heave Plates

The drag coefficient for a square heave plates is given as [8]

$$b_{22}^P = \frac{1}{2} C_D^P \rho B^2 \quad (77)$$

Where

$$C_D^P = 2 \quad (78)$$

#### VI. CALCULATION OF RESTORING COEFFICIENTS

The stiffness properties of the truss spar can be separate into two components; hydrostatic stiffness and mooring line stiffness. The mooring characteristic is non-linear, but one can assume that the restoring mooring force change linearly when given a small change in displacement from a steady state position. Also, for small amplitudes, the hydrostatic restoring forces are linearly proportional to displacement. The linear stiffness matrix can be written as

$$K = K_{hydrostatic} + K_{mooring} \quad (79)$$

The hydrostatic component obtained from basic stability theory, which gives the following coefficients:

$$K_{22}^h = \rho g A_w = \rho g \pi r^2$$

$$K_{33}^h = \rho g \nabla(GM) = \rho g \nabla(y_B - y_G) + \rho g \frac{\pi r^4}{4} \quad (80)$$

The restoring coefficients due to mooring stiffness can also obtained if one assume the mooring stiffness to be linear. Let  $K_x$ , be the horizontal mooring stiffness, then [11],

$$K_{11}^m = K_x$$

$$K_{13}^m = K_x (y_p - y_G)$$

$$K_{31}^m = K_x (y_p - y_G)$$

$$K_{33}^m = K_x (y_p - y_G)^2 \quad (81)$$



The first order wave exciting forces and moments on the truss spar are loads on the stationary structure due to linear incident waves (Diffraction problem). The methods used are very much dependent on the size and geometry of the structure. The truss spar consists of a large volume hull and a truss section with slender structural members. Diffraction of waves becomes important on the spar hull and Morison's approach will give a good approximation for calculating the forces on the truss section where diffraction is small. Since the truss section is far below the free surface, and drag force decay fast with depth, the drag forces are assumed to be negligible. Further, by assuming that there is no interaction between the structural components, the structure can be separated into smaller sub structures. In other words, the forces are calculated separately for each structural component, then added together to obtain the total wave exciting force on the truss spar.

- Truss Section

The truss section is a framework of circular members with different dimensions and inclined in different directions. This complex geometry makes it difficult to predict the wave excitation forces. By assuming that there will be no hydrodynamic interaction between the members each member can be analysed separately. Then the forces for each member are summed together to obtain the total force. The drag force is assumed to be insignificant and is therefore neglected. The Morison equation reduces to the inertia term only. A modified inertia term of Morison's equation can be written as

$$dF^n = (1 + C_a) \rho \pi r^2 a_n \quad (82)$$

Where  $C_a$  is the added mass coefficient and  $a_n$  is the fluid acceleration normal to the cylinder axis, evaluated at the center of the cylinder. The radius of the cylinder is  $r$ . For simplicity, let the structure reference system be aligned with the wave reference system except for the origin. The origin is placed at the center of gravity instead of the mean free surface. (See Fig. 2), i.e.

$$\begin{aligned} x_w &= X \\ y_w &= Y + Y_G \\ z_w &= Z \end{aligned} \quad (83)$$

The total inertia force is obtained by integrating this strip force along the cylinder axis. The force components in the member reference system's  $v$ - and  $w$ -direction can be shown to be [7],

$$\begin{aligned} F_{Iw} &= (1 + C_a) \rho \pi r^2 \left\{ \int_0^l \psi_{13} \dot{U}_x du + \int_0^l \psi_{23} \dot{U}_y du \right\} \\ F_{Iv} &= (1 + C_a) \rho \pi r^2 \left\{ \int_0^l \psi_{12} \dot{U}_x du + \int_0^l \psi_{22} \dot{U}_y du \right\} \end{aligned} \quad (84)$$

where  $\dot{U}_x$  and  $\dot{U}_y$  are the horizontal and vertical fluid particle acceleration. By using (83), trigonometric identities and integrating, the expressions above can be rewritten as

$$\begin{aligned} F_{Iw} &= A \frac{\sqrt{\psi_{13}^2 + \psi_{23}^2}}{k(\psi_{21} + i\psi_{11})} e^{i(kX_1 + \phi_1)} \left[ e^{k(\psi_{21} + i\psi_{11})l} - 1 \right] e^{-i\alpha} \\ F_{Iv} &= A \frac{\sqrt{\psi_{12}^2 + \psi_{22}^2}}{k(\psi_{21} + i\psi_{11})} e^{i(kX_1 + \phi_2)} \left[ e^{k(\psi_{21} + i\psi_{11})l} - 1 \right] e^{-i\alpha} \end{aligned} \quad (85)$$

Where

$$\begin{aligned} A &= -\frac{1}{2} (1 + C_a) \rho g \pi r^2 H_w k e^{k(Y_1 + Y_G)} \\ \tan \phi_1 &= \frac{\psi_{13}}{\psi_{23}}, \quad \tan \phi_2 = \frac{\psi_{12}}{\psi_{22}} \end{aligned} \quad (86)$$

Further, the inertia term of the pitch moment is given as

$$\begin{aligned} M_I &= \frac{A e^{ikX_1}}{k(\psi_{21} + i\psi_{11})} \left[ \psi_{33} \sqrt{\psi_{12}^2 + \psi_{22}^2} e^{i\phi_2} - \psi_{32} \sqrt{\psi_{13}^2 + \psi_{23}^2} e^{i\phi_1} \right] \times \\ &\left[ \left( l - \frac{1}{k(\psi_{21} + i\psi_{11})} \right) e^{k(\psi_{21} + i\psi_{11})l} + \frac{1}{k(\psi_{21} + i\psi_{11})} \right] + \\ &F_{Iw} (X_1 \psi_{23} - Y_1 \psi_{13}) + F_{Iv} (X_1 \psi_{22} - Y_1 \psi_{12}) \end{aligned} \quad (87)$$

There is a special case for  $\psi_{11} = \psi_{21} = 0$ , i.e. the strip force remains constant along the member. Then (85) and (87) reduces to

$$\begin{aligned} F_{Iw} &= A \sqrt{\psi_{13}^2 + \psi_{23}^2} e^{i(kX_1 + \phi_1)} l e^{-i\alpha} \\ F_{Iv} &= A \sqrt{\psi_{12}^2 + \psi_{22}^2} e^{i(kX_1 + \phi_2)} l e^{-i\alpha} \\ M_I &= A e^{ikX_1} \left[ \psi_{33} \sqrt{\psi_{12}^2 + \psi_{22}^2} e^{i\phi_2} - \psi_{32} \sqrt{\psi_{13}^2 + \psi_{23}^2} e^{i\phi_1} \right] \frac{l^2}{2} + \\ &F_{Iw} (X_1 \psi_{23} - Y_1 \psi_{13}) + F_{Iv} (X_1 \psi_{22} - Y_1 \psi_{12}) \end{aligned} \quad (88)$$

When the local member forces and moment are calculated by (85) and (87) or (88), it can be transformed into global forces along the principal axis, given by

$$\begin{aligned} F_X &= \psi_{13} F_{Iw} + \psi_{12} F_{Iv} \\ F_Y &= \psi_{23} F_{Iw} + \psi_{22} F_{Iv} \\ M_Z &= M_I \end{aligned} \quad (89)$$

Then the forces and moments from each truss member are added together to obtain the total force on the truss section.

- Spar Hull

The total surge force acting on the spar hull have been approximated using the linear diffraction theory of McCamy and Fuchs [12], although strictly speaking it applies to a bottom standing cylinder, and the spar hull is a truncated cylinder. The force can be written as [13],

$$F_1^H = \frac{2\rho g H_w}{k^2} A(kr) [1 - e^{-kd}] e^{i\alpha_1} e^{-i\alpha}$$

$$A(kr) = \frac{1}{\sqrt{J_1'(kr)^2 + Y_1'(kr)^2}} \quad (90)$$

$$\tan \alpha_1 = \frac{J_1'(kr)}{Y_1'(kr)}$$

Where  $d$  is the distance from bottom of the hull to the free surface (see Fig. 5), and  $r$  is the radius of the hull and  $J_1'(kr)$ ,  $Y_1'(kr)$  are the first order Bessel functions of first and second kind, respectively.

Weggle & Rosset [14], derived an expression for the total vertical diffraction force on truncated cylinder range of  $kr$  values, ( $0 < kr < \pi$ ). The expression was obtained by comparing the Froude-Krylov force on the bottom of a truncated cylinder with the vertical diffraction force obtained in experiments. From this comparison a diffraction coefficient ( $1 - 0.5 \sin(kr)$ ) was obtained. The Froude-Krylov force can be obtained by integrating the dynamic pressure over the bottom of the spar hull. Therefore:

$$F_2^H = \rho g H_w \pi r^2 [1 - 0.5 \sin(kr)] \left( \frac{J_1(kr)}{kr} \right) e^{-kd+i\alpha_2} e^{-i\alpha} \quad (91)$$

The pitch moment can be obtained by integrating the product of the surge force given in (90) and lever arm  $R$  (see Fig. 5) along the cylinder axis. The pitch moment is given as

$$dM_z = -rdF_x \quad (92)$$

Or

$$M_3^H = \frac{2\rho g H_w}{k^2} A(kr) \left[ \left( Y_G + \frac{1}{k} \right) - e^{-kd} \left( Y_G + d + \frac{1}{k} \right) \right] e^{i\alpha_1} e^{-i\alpha} \quad (93)$$

- Heave Plates

Since these solid plates are located far below the free surface drag forces are assumed to be small and therefore neglected. Also, there will not be any Froude-Krylov force due to the infinitesimal thickness. The plates do not contribute to the surge force and pitch moment is assumed to be small and neglected. The only significant wave force component on the plates is the vertical acceleration force. The heave force on square, solid plate at the depth  $y = y_1$  is then given as

$$F_2^P = M_2^{A.P} \dot{U}_y \quad (94)$$

Where  $\dot{U}_y$  the vertical fluid particle acceleration is evaluated in the center of the plates, and  $M_2^{A.P}$  is the added mass coefficients for solid plate given as [15],

$$M_2^{A.P} = C_a^P \frac{\rho}{4} \pi B_p^3 \quad (95)$$

Where  $C_a^P = 0.58$  and  $B^P$  is solid plate side.

$$F_2^P = -C_a^P \frac{H_w \rho \pi}{8} \omega^2 e^{ky_1} B_p^3 e^{-i\alpha} \quad (96)$$

The total wave exciting force on the truss spar is obtained by adding the contributions from the spar hull, the plates and truss section.

### VIII. SOLUTION OF MOTION EQUATION

The response of a truss spar in waves can be obtained by solving (2) when the force components are known. The viscous damping term gives a non-linear term in the equation of motion and must therefore be linearised [1]-[7]. This can be done by using the equivalent damping term. In other words, let  $B_{nl}^{eq}$  approximate  $B_{nl}|\dot{X}|$  in (2) so that they both dissipate the same energy at resonance. This gives

$$B_{nl}^{eq} = \frac{8\omega}{3\pi} B_{nl} |X_0| \quad (97)$$

Where  $|X_0|$ ,  $|Y_0|$  and  $|\theta_0|$  are the amplitudes in surge, heave and pitch, respectively.

Introducing the equivalent linearised damping term into (2) gives a new set of equation, which must be solved by an iterative technique [1]. Equation (2) can now written as

$$(M + m)\ddot{X} + B_{nl}^{eq} \dot{X} + KX = F_0 e^{-i\alpha} \quad (98)$$

When, complex notation is used. The solution is assumed to be harmonic, i.e.

$$X = X_0 e^{-i\omega t} \quad (99)$$

Where,  $X_0$ , is a complex amplitude vector. The time derivative of  $X$  is given:

$$\begin{aligned} \dot{X} &= -i\omega X_0 e^{-i\omega t} \\ \ddot{X} &= -\omega^2 X_0 e^{-i\omega t} \end{aligned} \quad (100)$$

Introducing (99) and (100) into (98) gives

$$[-\omega^2(M + m) - i\omega B_{nl}^{eq} + K]X_0 e^{-i\alpha} = F_0 e^{-i\alpha} \quad (101)$$

And the solution becomes

$$X_0 = [-\omega^2(M + m) - i\omega B_{nl}^{eq} + K]^{-1} F_0 \quad (102)$$

The response amplitudes are now given as complex numbers,

$$X_0 = \begin{bmatrix} X_1 \\ X_2 \\ \cdot \\ \cdot \\ X_n \end{bmatrix} = \begin{bmatrix} X_1^{Re} + iX_1^{Im} \\ X_2^{Re} + iX_2^{Im} \\ \cdot \\ \cdot \\ X_n^{Re} + iX_n^{Im} \end{bmatrix} \quad (103)$$

Where the magnitude is

$$\max(X_i) = |X_i| = \sqrt{(X_i^{Re})^2 + (X_i^{Im})^2} \quad (104)$$

The *response amplitude operator*, RAO, is defined as the response divided by wave amplitude [16].

$$RAO_i = \frac{|X_i|}{0.5H_w} = \frac{\sqrt{(X_i^{Re})^2 + (X_i^{Im})^2}}{0.5H_w} \quad (105)$$

The RAOs can be combined with a wave spectrum to obtain the response spectrum. The response spectrum of the *i*th mode of motion is given as [16],

$$RS_i(\omega) = |RAO_i|^2 S(\omega) \quad (106)$$

The response spectrum can thereafter be used to obtain the significant response amplitude given as [16]

$$X_{sig,i} = 2\sqrt{\int_0^\infty RS_i(\omega) d\omega} \quad (107)$$

- Natural Frequency

The responses are expected to be significant at the structures natural frequencies (or resonance frequency) where the mass and restoring forces cancel. At or near these resonance frequencies, the truss spar will experience response of large amplitudes. However, these resonance responses are inversely proportional to the damping so that large damping gives small response. The undamped and uncoupled natural frequency is given as

$$\omega_{n,i} = \sqrt{\frac{k_{ii}}{M_{ii} + m_{ii}}} \quad (108)$$

IX. NUMERICAL STUDY

- Natural Frequency

In Table I, the natural frequency in heave, surge and pitch compared with measured values reported by Stansberg et al [3].

**TABLE I**  
Natural frequencies

	Surge motion	Heave motion		Pitch motion	
		L.P	S.P	L.P	S.P
Estimated	0.0123	0.197	0.247	0.102	0.102
Measured	0.0123	0.209	0.251	0.102	0.097
Deviation (%)	0	-5.74	-1.59	0	5.15

L.P, large heave plates; S.P, small heave plates

- Wave frequency response

The surge, heave and pitch responses of the truss spar are derived for a sea-state defined by the JONSWAP wave spectrum, with a significant wave height of 15m and a peak spectral period of 15s.

The RAOs for the truss spar with large and small heave plates are shown in the following figures. The estimated values are plotted together with the experimental results.

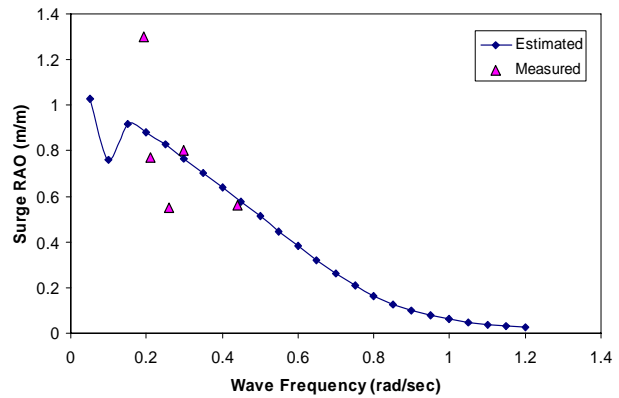

Fig. 6 Estimated and measured surge RAO with large, solid heave plates.

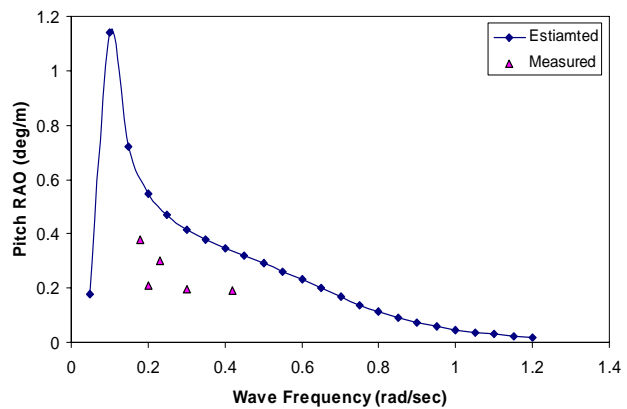

Fig. 7 Estimated and measured pitch RAO with large, solid heave plates.

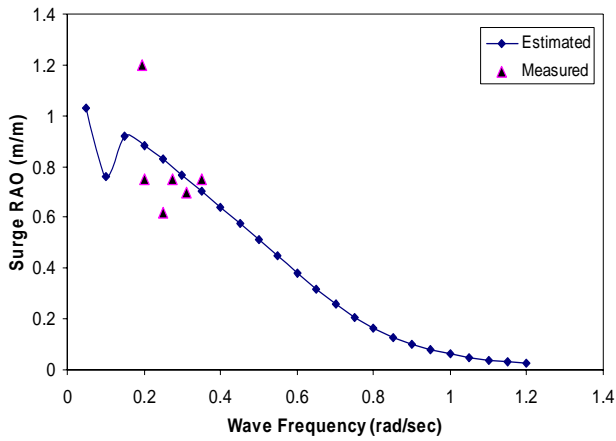

Fig. 8 Estimated and measured surge RAO with small, solid heave plates.

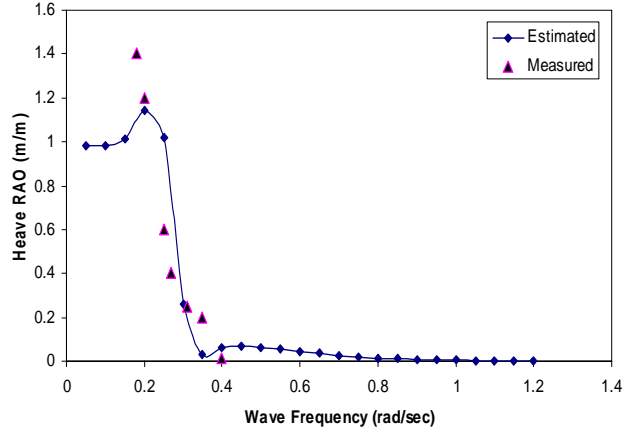

Fig. 11 Estimated and measured heave RAO with small, solid heave plates.

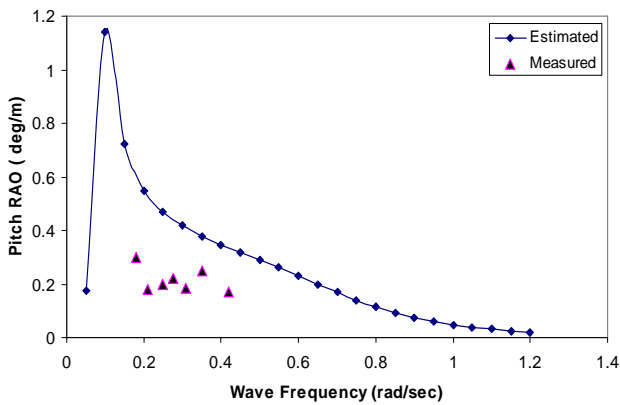

Fig. 9 Estimated and measured pitch RAO with small, solid heave plates.

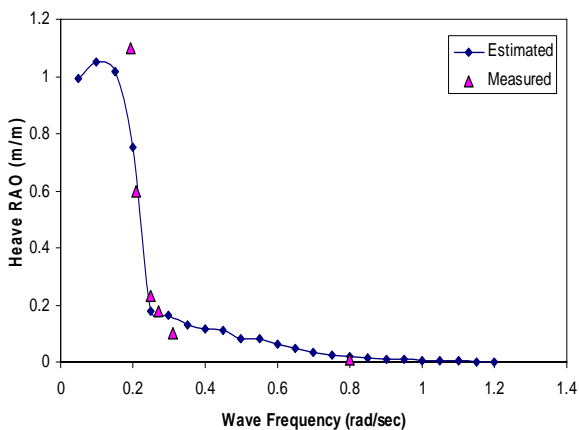

Fig. 10 Estimated and measured heave RAO with large, solid heave plates.

In Figs. 6, 7, 8,9,10 and 11, the RAOs estimated by (105). For the truss spar with small and large, solid heave plates are compared with the experimental results reported by Downie et al [4]. The measured RAOs for surge and heave displacement shows a small scattered formation. The estimated surge RAO correlates well with the measured RAO as a mean value. A local peak at the pitch natural frequency can be observed on the surge RAO. This is due to the coupling effect between surge and pitch. The estimated pitch RAO seems to be slightly over predicted compared to the experimental results. A small change in mass moment of inertia can give significant change in the pitch RAO, and since this is a large uncertainty in the input data, this is also expected to reflect the results. Nevertheless, the results are still comparable, even though it over predicts the measured results. The theoretical heave RAO shows good agreement with the experimental results.

The significant wave frequency response amplitudes obtained from the simulation and the experiment are summarized in Table II.

**TABLE II**  
The significant response amplitude

	Surge motion	Heave motion		Pitch motion	
		L.P	S.P	L.P	S.P
Estimated	4.508	0.581	1.058	2.672	2.334
Measured	-	0.360	1.040	2.336	2.574
Deviation (%)	-	61.38	1.73	14.38	-9.32

L.P, large heave plates; S.P, small heave plates

For heave result where slightly over predicted.

X. CONCLUSION

In this article, the linear hydrodynamic analysis of a truss spar in random waves has been formulated and investigated theoretically for three modes of motion. This investigation was done in order to understand the dynamic behaviour of a truss

spar in waves. Drag forces has been neglected, but viscous damping is considered in the calculations. The result has been used to develop a Matlab computer program, which solves the linear hydrodynamic analysis in frequency domain. Furthermore, the theoretical work in this article has been validated against experimental results. The wave frequency response was well predicted by the theoretical model used. The estimated values for heave and pitch was over estimated but within acceptable limits.

## APPENDIX

## - Numerical data

Mass and added-mass coefficients:  $M= 52100$  tonne;  
 $I_{33}= 297000000 \text{ tonne} - m^2$ ;  $a_{11}=50502.43$  tonne;  
 $a_{12}= a_{21}= 0$ ;  $a_{22}=150423.78$  tonne (large heave plate);  $a_{22}=76092.88$  tonne (small heave plate);  
 $a_{13}= a_{31}=-388068.6$  tonne-m;  $a_{23}= a_{32}=0$ ;  
 $a_{33}=51143498.77 \text{ tonne} - m^2$ .

Restoring coefficients:  $K_{11}=15.5$  kN/m;  $K_{31}= -155$  kN;  
 $K_{13}= -155$  kN;  $K_{22}= \text{kN/m}$ .  $K_{33}= 3317284.381$  kN.

Damping coefficients:  $b_{11}= 1385.57$  tonne/m;  
 $b_{13}= 8379186.21$  tonne-m;  $b_{31}=67151.33$  tonne;  
 $b_{33}= 1118595134.39 \text{ tonne} - m^2$ ;  $b_{22}=8387.01$  tonne/m  
(large heave plate);  $b_{22}=5315.85$  tonne/m (small heave plate).

## REFERENCES

- [1] M. Patel, J. Witz, "Compliant Offshore structures," Butterworth-Heinemann Ltd.: Oxford, UK, 1991.
- [2] S. Chakrabarti, "Hydrodynamics of Offshore Structures," Computational Mechanics Publications, Southampton. ISBN 0 905451 66 X, 1987.
- [3] CT. Stansberg, I. Nygaard, H. Ormberg, et al, "Deep-water truss spar in waves and current-experiments vs. time-domain coupled analysis," Deep Offshore Technology Conference, Rio de Janeiro, 2001.
- [4] MJ. Downie, JMR Graham, C. Hall, et al, "An experimental investigation of motion control devices for truss spars," Marine Structures 13:75-90, 2000.
- [5] I. Nygaard, W. Lian, CT. Stansberg, "Motion behaviour of a truss spar in deep water," Deep Offshore Technology Conference, New Orleans, 2000.
- [6] K. Sadeghi, A. Incecik, "An Approximation Model for the First- and Second-Order Dynamic Response Analysis of Truss Spar platforms," 25<sup>th</sup> conf. on Offshore Mechanics and Arctic Engineering, Hamburg, Germany, 2006.
- [7] A. Incecik, "Design Aspects of Hydrodynamic and structural Loading on Floating Offshore Platforms under Wave Excitation," PhD thesis University of Glasgow, UK, 1982.
- [8] M. Patel, "Dynamics of Offshore Structures," Butterworth-Heinemann, ISBN 10:0 408 01074 6, 1989.
- [9] O. Falinsen, "Sea Loads on Ships and Offshore Structure," Cambridge, Ocean Technology Series, Cambridge University Press, Cambridge, UK. ISBN 0 521 45870 (paperback), 1990.
- [10] J.N. Newman, "Marine Hydrodynamics," The MIT press, Massachusetts, USA. ISBN 0 262 14026 8, 1977.
- [11] B. Mekha, D. Weggel, C. Johnson, J. Rosset, "Effects of Second order Diffraction Forces in the Global Response of Spars," in' Proceeding of the sixth International Offshore and Polar Engineering Conference', Vol. 1, The International Society of Offshore and Polar

- [12] R.C. McCamy, RA. Fuchs, "Wave Forces on Pile: A Diffraction Theory," US Army Corps of Engineering, Beach Erosion Board, Technical Memo No. 69 pp 1-13, Washington, DC, 1954.
- [13] JM. Niedzwecki, AS. Duggal, "Wave run-up and forces on cylinder in regular and random waves," J Waterway Port Coast Ocean Eng 118:615-634, 1992.
- [14] D. Weggel, J. Rosset, "Vertical hydrodynamic forces on truncated cylinders," in'Proceedings of the fourth International Offshore and Polar Engineering Conference', Vol. 3, The International Society of Offshore and Polar Engineers, ISOPE, Osaka, Japan, pp. 210-217. ISBN 1 880653 13 3 (vol. 1), 1994.
- [15] T. Sarpkaya, M. Isaacson, "Mechanics of Wave Forces on Offshore Structures," van Nostrand Reinhold Company, New York, USA. ISBN 0 442 25402 4, 1981.
- [16] A. Incecik, "Lecture notes in mar855 advanced offshore design," Department of Marine Technology, University of Newcastle, UK, 1999.