

Two Different Solutions for Gigabit Ethernet Transmission over POF

Stefano Straullu, Silvio Abrate, Antonino Nespola, Paolo Savio and Roberto Gaudino

Abstract—Two completely different approaches for a Gigabit Ethernet compliant stream transmission over 50m of 1mm PMMA SI-POF have been experimentally demonstrated and are compared in this paper. The first solution is based on a commercial RC-LED transmission and a careful optimization of the physical layer architecture, realized during the POF-PLUS EU Project. The second solution exploits the performance of an edge-emitting laser at the transmitter side in order to avoid any sort of electrical equalization at the receiver side.

Keywords—Gigabit Ethernet, Home Networking, Step-Index Polymer Optical Fiber (SI-POF)

I. INTRODUCTION

LARGE core (1mm) PMMA-based Step Index Polymer Optical Fibers (SI-POF) have gained interest, in the recent years, as a possible medium for home and office networking due to their ease of installation, use and maintenance. Analysis about the rationale for employing this type of fibers in this particular environment instead of other better-performing fibers, such as GOF, Graded Index POF (GI-POF) or Perfluorinated POF (PF-POF), are widely available in literature (see for example [1], [2]). Moreover, some Telecom operators in Europe start to offer a 100Mbit/s POF kit for home installations and this commercial development is triggering a significant research activity on the “next generation” POF systems that are focused on transmitting a Gigabit Ethernet stream over a target distance of at least 50 meters, which is considered a typical length for home networking scenarios. In this direction, a first standardization activity has been concluded in ETSI with the approval of the TS 105 175-1 specification, titled “Plastic Optical Fiber System Specifications for 100Mbit/s and 1Gbit/s”, and a new standardization initiative inside VDE-DKE titled WG 412.7.1 “Optical Data Transmission Over Plastic Optical Fiber (POF)” was founded in December 2009.

At the end of the POF-PLUS EU project, for what concerns its task about 1Gbit/s transmission over SI-POF, we implemented a fully working Ethernet compatible prototype, based on commercial optoelectronics and on a Field Programmable Gate Array (FPGA) development board. The system is shown to work over a distance of 50m with system

S. Straullu, S. Abrate, A. Nespola and P. Savio are with the Istituto Superiore Mario Boella, Turin, Italy (phone: +39-011-2276-314; e-mail: straullu@ismb.it).

R. Gaudino is with the Politecnico di Turin, Turin, Italy (phone: +39-011-564-4172; e-mail: roberto.gaudino@polito.it).

margin, using a commercial RC-LED at the transmitter side. In order to achieve these results we have developed special full-fledged physical layer (PHY) compatible with the IEEE Gigabit Ethernet specifications and with all the impairments due to the propagation in the POF channel. The new PHY is based on custom Physical Medium Dependent (PMD) and Physical Coding (PCS) sub-layers, implementing Forward Error Correction (FEC) and Electronic Equalization.

In this paper we compare the results obtained with this low-cost solution to the performances obtained with a more expensive laser solution which, however, avoids the need of the electronic equalization and the FEC at the receiver side.

II. THE NEW PROPOSED PHYSICAL LAYER

The target performance of 50m with consistent system margin (at least 5dB), with the constraint of using eye-safety, robust and commercial optoelectronics, such as LED sources, lead to several limitations mainly due to an insufficient bandwidth. In order to overcome these limits, an extensive simulation campaign [3] and several off-line processing experiments have been carried. The different modulation formats and equalizers tested came out with a full-fledged Gbit Ethernet media-converter between POF and UTP cable whose physical layer has been organized in two sublayers as follows:

- Physical Medium Dependent (PMD) sublayer: this is the layer that specifies the optoelectronic components and, if required, implements digital signal processing on the transmitted and/or received signal;
- Physical Coding Sublayer (PCS): it is the sublayer responsible for interfacing to the higher layer (Medium Access Control (MAC) through the so called GMMI interface) and for line coding and signalling.

A. PMD sublayer

The PMD sublayer takes into account the impairments suffered by the optical signal along its fiber propagation. Given the goal of achieving a distance of 50 meters using low-cost and robust sources, the following architectural decisions have been taken:

- adoption of red sources: despite the high attenuation exhibited by POF in the red window, currently available green sources have shown insufficient performances in terms of speed/bandwidth. The selected source is thus red RC-LED;
- an adaptive equalization at the receiver. This is a must, since the received eye-diagrams are completely closed before equalization due to bandwidth limitations (mostly

imposed by the POF itself). We selected a Decision Feedback Equalizer (DFE) approach in an adaptive and blind version, so that neither training nor “a priori” knowledge of the channel is needed. More in detail, the DFE is a pipelined T-spaced 2 taps feedback filter, whose structure follows the parallel approach of nested multiplexer loops proposed by Oh and Parhi [4]. It works in combination with a T/2 spaced feed forward equalizer which is a 16 tap parallel systolic FIR filter. Both the feed-forward and feedback taps are updated according to the Delayed Least Mean Square (DLMS) algorithm. The error is estimated by switching smoothly between the blind Constant Modulus Algorithm (CMA) and the slower but more precise Direct Decision (DD). Specifically, when the equalizer starts to converge, the DD gradually takes over the CMA. On the contrary, the equalizer switches back from DD to CMA if it loses convergence. The system works entirely in the digital domain at a maximum clock frequency that is $\frac{1}{4}$ of the actual line rate (approximately 275MHz in our case, see later) thanks to a proper parallelization of the algorithm.

B. PCS sublayer

The PCS sublayer defines how a raw bit stream is grouped in code words and transmitted over a physical link; in particular, it handles bit coding, while maintaining all the signaling methods required by IEEE 802.3 Gigabit Ethernet Standard. Our new proposed PCS is shown in Fig. 1 and, for what concerns the transmitter side, it is based on the following building blocks:

- 64B/66B to 65B encoder (indicated as 64B/65B in the following): the input data stream, received by the GMMI, is grouped into 64-bit words and encoded into 65-bit words, according to the scheme suggested by the 74.7.4.3 clause of the IEEE 802.3-2008 standard [5] “Forward Error Correction (FEC) sublayer for 10GBASE-R PHYs”, an IEEE clause for the insertion of FEC on a sublayer of the 10GBASE-R PHYs. This encoder is the core of the proposed PCS: we have chosen this solution instead of the 8B/10B adopted by the Gigabit Ethernet standard in order to minimize the signaling overhead and thus to reduce the line-rate, to cope with the bandwidth requirements of the POF link. The 64B/65B encoder has all the signaling capabilities requested by Ethernet and, moreover, implements bit scrambling, which eases adaptive equalization (known on the contrary to have problems with pure 8B/10B), synchronization. Even though 64B/65B does not impose any strict DC-balancing, we experimentally tested that the scrambled data at its output does not suffer any significant penalty even with the (relatively high) 1MHz low frequency cut-off that characterizes our optoelectronic front-end;
- FEC encoder: in order to improve the power margin, we decided to adopt a common Reed Solomon RS(255, 237), working with an input of 237 8-bit words. A FEC

frame thus includes $237 \times 8 \text{bit} = 1896 \text{bit}$, corresponding to 29 words of 65bit (=1885bit) plus 11 remaining bits. In order to avoid the need for a synchronization at the 65-bit word level, the 65-bit word starts exactly at the beginning of the FEC frame. As a result, the 11 additional bits are filled with dummy data. The adoption of a FEC scheme, not foreseen by the 1000-BaseX standard, lets us set the sensitivity threshold of the optical system to a pre-FEC BER equal to 10^{-4} and still satisfy the 10^{-12} (after FEC) required by 1000-BaseX at the PHY level;

- PRBS generator, used as a seed for an additional bit scrambling with respect to the actions performed by the line encoder and FEC. In order to achieve this result, the generated PRBS sequence is added (XORed) to the FEC encoder output. Since the frame is given by 255 words of 8 bits, the natural choice is a 2^8-1 PRBS with a parallelism of 8, so that the periodicity and the parallelism of the PRBS generator exactly match the output of the FEC encoder. This additional scrambler, defined in a similar way as to clause 74.7.4.4.1 of [5] (where the used scrambler is different, but the principle is the same), has two significant advantages: it scrambles also the FEC overhead without requiring a further level of synchronization, since the used PRBS has the same alignment as the FEC output frame. Moreover (taken from [5]) scrambling with this PRBS sequence at the FEC codeword boundary is necessary for establishing FEC block synchronization (to ensure that any shifted input bit sequence is not equal to another FEC codeword) and to ensure statistical DC balance. At the same time, the increase in DSP complexity is minimal.

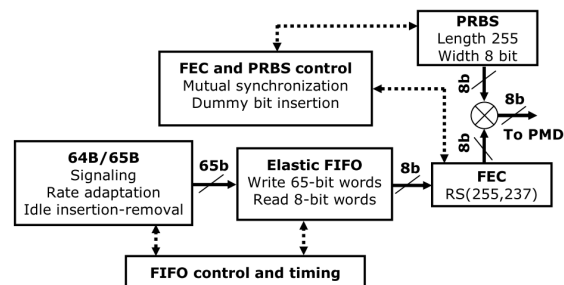

Fig. 1 Block diagram of the proposed PCS sublayer (transmitter part)

Logically, the corresponding receiving blocks are aligned in the reverse order at the receiver side, while the PCS synchronization is based on correct FEC decoding, thus not requesting any additional signalling. The adoption of the chosen line coding and FEC schemes then yields, given an input data rate from the GMMI equal to 1Gbps, a resulting line rate of 1.0991Gbps, thus granting a significant advantage, in terms of bandwidth, with respect to the 1.25Gbps that we would have achieved adopting the native 1000-BaseX PHY.

III. EXPERIMENTAL SETUP

The PHY presented in the previous Section has been implemented on a commercial FPGA platform (UHAB by Bitsim), equipped with two Xilinx Virtex4 FPGAs and fast ADC and DAC. Adding the needed optoelectronics to the platforms results in a prototype that can be actually intended as a full-duplex media converter between POF and UTP cable. Using two of these media-converters the system of Fig.2 has been designed and tested. The details of the system are:

- the FPGA, thanks to a daughterboard from Avnet, is able to receive the Gigabit Ethernet signal from a Personal Computer (or a Router Tester) through a UTP cable;
- the TCP traffic is applied to the PCS sublayer and then provided to the transmitter working at a line rate of 1.1Gbps;
- the optical source is a red RC-LED (produced by Firecomms and mounted on a driver circuit board realized by Fraunhofer). It is characterized by an average output optical power of -1.5dBm at 650nm, a Numerical Aperture (NA) of 0.35, an Optical Modulation Amplitude (OMA) of -2.8dBm;
- a 12.5Gb/s high-sensitivity limiter amplifier (iT3011 by iTerra) is placed in front of the transmitter, in order to square the signal at the output of the DAC of the FPGA, which is not good enough to directly modulate the RC-LED by itself;
- the signal is transmitted over 50m of fiber link, based on Luceat 1mm SI PMMA fiber, with a minimum optical attenuation of approximately 0.16dB/m in the red wavelength region;
- the optical-to-electrical conversion is performed by a laboratory receiver (SPD-2 model by Graviton) based on a PIN photodiode, followed by a transimpedance amplifier;
- the signal is then filtered through an anti-aliasing, 1GHz bandwidth, low-pass filter and sent to the real-time adaptive equalizer stored in the second FPGA, using the FFE+DFE approach, and to the corresponding receiving blocks of the PCS, aligned in the reverse order with respect to the transmitter side. The PCS synchronization is based on correct FEC decoding, thus not requesting any additional signalling;

- such FEC is able to completely remove the errors until the BER of the equalized signal at its input is lower than 10^{-4} , providing the overall system in the “error-free” condition (in agreement with the ETSI TS 105 175-1 V1.1.1, the BER must be $<10^{-6}$);
- the received and decoded bits are finally sent back to the router tester, in order to measure the system BER and FEC behavior, thanks to its monitor interface;
- the same data stream is reproduced exactly as explained above in the reverse way, since the system is full-duplex.

IV. EXPERIMENTAL RESULTS

We performed a first set of measurements at the PHY level (as we did in our previous publication [6]), estimating the BER before FEC decoding as a function of the received optical power at the output of the 50 meters system. We achieved different values of the received optical power acting on a Variable Optical Attenuator (VOA) placed along the signal path. The VOA is simply built by a free-space gap between two ends of POF. When the VOA is set to its minimum value, the received optical power is -9.5dBm, for a total link attenuation, due to the fiber and the two end connectors, of 8dB. Then we measured the BER increasing the VOA attenuation by 0.5dB steps over a large power range, in order to evaluate the system margin when adopting the FEC and the equalizer. The same measurement campaign was carried out increasing the POF length to 75 meters, resulting in a received optical power of -13.5dBm, for a total link attenuation of 12dB. As depicted in Fig. 3, in both cases the FEC threshold is reached when the received optical power is -16dBm. This power level is achieved introducing respectively 6.5dB of extra attenuation for the 50m link and 2.5dB for the 75m link, which are thus the available system margins of the two systems. We believe that the obtained power margin for the 50m link is reasonable for taking into account fiber and components ageing and additional attenuations due to eventual intermediate connector-splices (<1.5 dB each) and several severe fibre bends (<0.2 dB each 90° bend with a radius of 12mm, according to the previously mentioned ETSI TS 105 175-1 specification) in a real domestic installation.

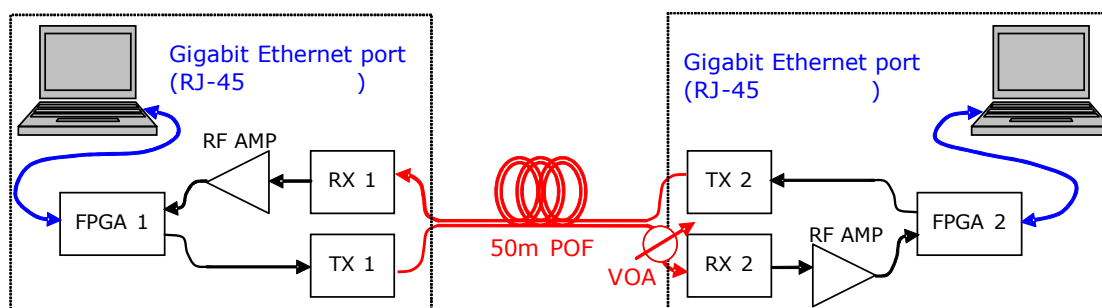

Fig. 2 Schematic block of the full-duplex Gigabit Ethernet system

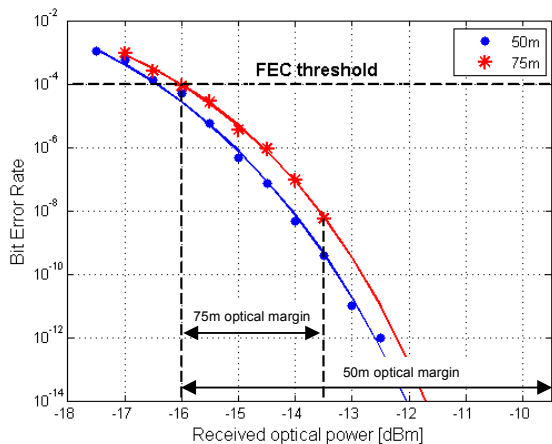

Fig. 3 BER measurement before FEC as a function of the received optical power for the 50m and 75m links

We repeated a similar measurement using an external router tester (Agilent N2X) in order to perform network layer measurements. The most relevant results are as follows:

- the end-to-end latency on a link including two media converters is lower than 16µs, a very low value mostly determined by the FEC frames coding and decoding;
- the achievable throughput of the link is 100%, loading the system with variable length of Ethernet frames (from 64bytes to 1518bytes);
- the resulting packet loss as a function of the received optical power for the 50m link is given in Fig. 4. It has been measured using the router tester at the Ethernet layer through FCS errors and IPv4 checksum errors. This result confirms that the developed system is virtually error-free above -16dBm of received optical power.

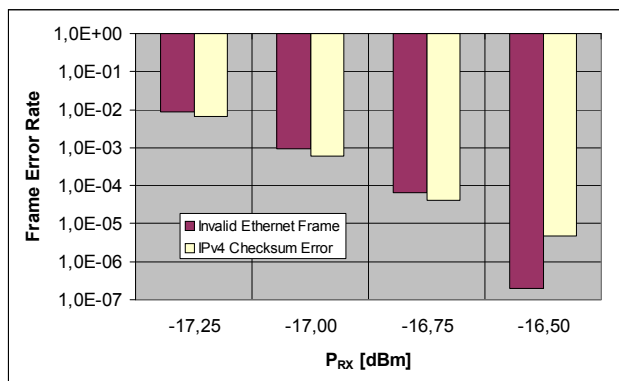

Fig. 4 Ethernet packet-error-rate and IPv4 Checksum error rate as a function of the received optical power for the 50m link

V. THE SOLUTION WITH LASER

The last step of our measurement campaign is based on a totally different approach. As mentioned before, we tested a second solution based on an expensive and not robust transmitter. We, thus, replaced the RC-LED with a directly modulated red edge-emitting laser (from UnionOptronics

Corp. SLD-650-P10-RG-03), which is characterized by an average output optical power of 6.5dBm at 650nm, with an OMA of about 8.8dBm. Thanks to these characteristics, the eye-diagram of the signal after 50m of POF is good enough to avoid any sort of equalization, as depicted in Fig. 5. Therefore, neglecting the robustness of the source, the higher cost of the laser is balanced by the complete absence of electronic equalization and FEC, a fact that allows to save power consumption and electronic complexity.

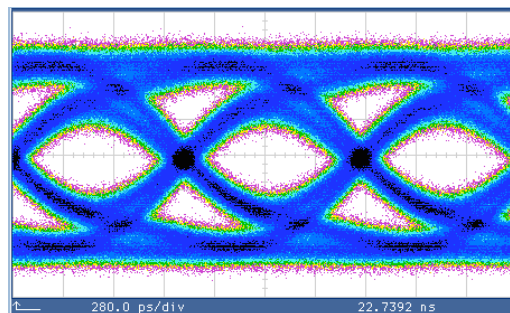

Fig. 5 Eye-diagram of the received signal after 50m of POF using laser

The required PCS (transmitter side) has been updated and simplified as depicted in Fig. 6, providing a resulting line rate of 1.019185Gbps, whereas the PMD sublayer is used just to serialize/deserialize the transmitted/received data.

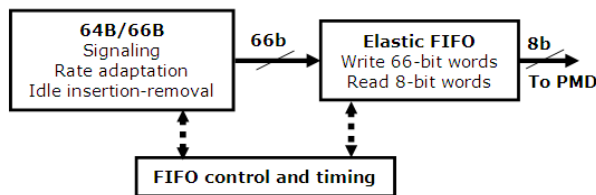

Fig. 6 Block diagram of the updated PCS sublayer (transmitter part)

With this new solution, we repeated the same measurement campaign described above but, because of the lack of the FEC, we computed the optical power margin of the system as the difference between the maximum received optical power and the power at which the BER is lower than 10⁻⁹, reached acting on the VOA as explained above. Measurements proved that the received power after 50m of SI-POF is about -3.5dBm and the achieved BER is lower than 10⁻⁹ until a received power of -18dBm. This allows to conclude that the optical power margin of the system is 14.5dB as depicted in Fig. 7.

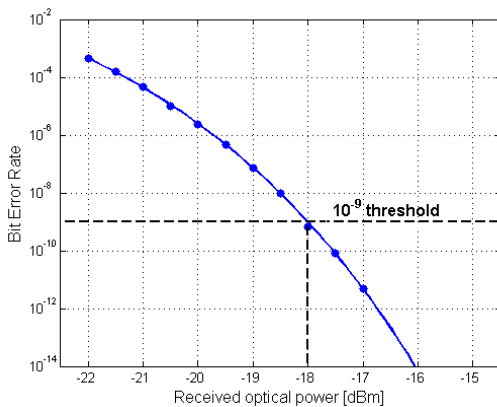

Fig. 7 BER measurement as a function of the received optical power for the 50m link using laser

Despite this wide margin, we verified that, after 75 meters, the signal is too distorted to provide a BER of 10^{-9} , without the help of an electronic equalizer, as it is possible to notice from Fig. 8. This is probably due to the fact that the modal dispersion does not grow linearly along the fiber, but it results more relevant in the range between 50 and 75 meters.

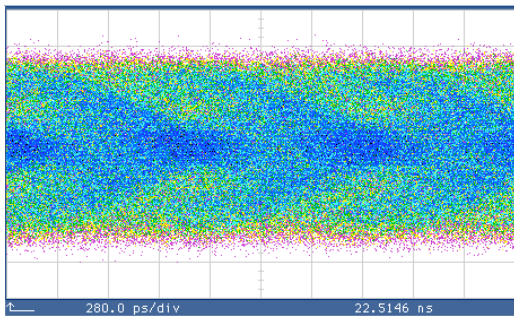

Fig. 8 Eye-diagram of the received signal after 75m of POF using laser

VI. CONCLUSION

With this paper, we experimentally demonstrated that POF is a really interesting media for home networking, not only thanks to its mechanical characteristics, that make it robust and easy to install, but for its high performances as well. Two different solutions for the real-time transmission of the Gigabit Ethernet signal over 50 meters of standard SI-POF, with consistent system margin, have been described. The first solution focuses on a strong electronic equalizer at the receiver side, capable to recover the completely distorted signal (due to the high modal dispersion characteristic of the channel) provided by an eye-safety, low cost, commercial transmitter like the RC-LED. This equalizer provides a good optical system margin (6.5dB) and it is able to recover the signal after 75 meters too. The second solution allows dismissing any sort of electronic equalization, saving power consumption and electronic complexity, as long as a more performing transmitter is exploited. The edge-emitting laser we tested does

not satisfy the eye-safety target but, thanks to its high transmitted optical power and OMA, it provides an error-free transmission after 50 meters with good margin.

ACKNOWLEDGMENT

This work was supported by EU STREP project POF-PLUS.

REFERENCES

- [1] O. Ziemann, J. Krauser, P. Zamzow, and W. Daum, POF Handbook: "Optical Short Range Transmission Systems", 2nd ed. New York: Springer, 2008.
- [2] A. Nespola, S. Abrate, R. Gaudino, C. Zerna, B. Offenbeck, and N. Weber, "High-speed communications over polymer optical fibers for in-building cabling and home networking", IEEE Photon. J., vol. 2, no. 3, pp. 347–358, Jun. 2010.
- [3] S. Abrate, A. Nespola, S. Straullu, P. Savio, R. Gaudino, A. Antonino, C. Zerna, B. Offenbeck, N. Weber, "Gigabit home networking with 1mm PMMA fibers", IEEE International Conference on Transparent Optical Networks 2010.
- [4] Daesun Oh and K.K Parhi, "Low Complexity Design of High Speed Parallel Decision Feedback Equalizers", Proceedings of the IEEE 17th International Conference on Application-specific Systems, Architectures and Processors (ASAP 2006), Colorado, September 11-13, 2006.
- [5] IEEE 802.3-2008 Part 3: "Carrier Sense Multiple Access with Collision Detector (CSMA/CD) access method and Physical Layer specifications".
- [6] A. Nespola, S. Straullu, P. Savio, D. Zeolla, J. Ramirez Molina, S. Abrate, R. Gaudino, "A new physical layer capable of record gigabit transmission over 1mm step-index polymer optical fiber", J. Lightw. Technol., vol. 28, no. 20, pp. 2944–2950, Oct. 15, 2010.

Stefano Straullu graduated in telecommunications engineering in 2005 from the Politecnico di Turin, Turin, Italy, with a thesis about the project, the realization and the testing of opto-electronic subsystems for packet-switched optical networks, realized in the PhotonLab of Istituto Superiore Mario Boella of Turin. In 2006, he joined the Integration Testing team of Motorola Electronics S.p.A. of Turin, working on the mobile devices and live network testing. Since May 2009, he has been a researcher at the Istituto Superiore Mario Boella, Turin, Italy, with responsibilities of project, realization and testing measurements of opto-electronic systems and he has published more than 20 journal and conference papers.

Silvio Abrate graduated in Telecommunications Engineering in 1999 at Politecnico di Torino, with a thesis about the distribution of satellite television over an in-building fiber infrastructure. Since 2001 he was with the Optical Networks Division of Alcatel S.p.A., in Vimercate (MI), working on SDH and WDM networks especially for Telecom Italia and South America's providers. Since February 2003 he is a senior researcher at Istituto Superiore Mario Boella, with the role of coordinator of the PHOTonic Technologies and Optical Networks Laboratory (PhotonLab) held by the institute in cooperation with Politecnico di Torino. Silvio Abrate is author or co-author of over 60 journal and conference papers, and holds 4 U.S./European patents.

Antonino Nespola received his M.S. and Ph.D. degrees in Electrical Engineering from the Politecnico di Torino, in 1995 and 2000, respectively. From 1997 to 1998, he was a Visiting Researcher in the Photonics Laboratory of the University of California Los Angeles. From 1999 to 2003 he was Member of Technical Staff and R&D Lab Director in Corning, Milan, where he conducted research in high-speed opto-electronics. In 2003, he joined Pirelli Labs, Milan, as senior researcher. He is currently senior researcher at ISMB. Antonino Nespola has published over 60 journal and conference papers, and holds 4 U.S./European patents.

Paolo Savio received the M.S degree in Electrical Engineering from the Politecnico di Torino (Torino, Italy) and the University of Illinois at Chicago (following the TOP-UIC exchange program) in 1999. In 2000 he joined Accent srl, Vimercate (Mi), Italy, working on integrated circuit design and verification. From 2004 to 2008 in Fondazione Torino Wireless, he was involved in technology transfer and acceleration activities for SMEs, following the development of innovative prototypes. He is currently with

Istituto Superiore Mario Boella, taking care of the FPGA and microcontroller implementation of DSP algorithms and control structures.

Roberto Gaudino Ph.D., is currently assistant Professor at Politecnico di Torino, Italy. Dr. Gaudino's main research interest is in the long haul DWDM systems, fiber non-linearity, modelling of optical communication systems and on the experimental implementation of optical networks. Starting from his previous researches on fiber modelling, on new optical modulation formats, such as duo-binary, polarization or phase modulation, and on coherent optical detection, he is currently investigating on packet switched optical networks, and on short-reach optical links using plastic optical fibers. Dr. Gaudino spent one year in 1997 at the Georgia Institute of Technology, Atlanta, as a visiting researcher, where he worked in the realization of the MOSAIC optical network test-bed. He also co-operates with several Italian Universities and research centers on joint research programs. From 1998, he is with the team that coordinates the development of the commercial optical system simulation software OptSim (Artis Software Corp., now acquired by RSoft Design). He has consulted for several companies and he is author or co-author of more than 80 papers in the field of Optical Fiber Transmission and Optical Networks. He has been the coordinator of the EU FP6-IST STREP project "POF-ALL" and currently is the scientific coordinator of the EU FP7-ICT STREP project "POF-PLUS".