

Analysis of Self Excited Induction Generator using Particle Swarm Optimization

Hassan E. A. Ibrahim, Mohamed F. Serag

Abstract—In this paper, Novel method, Particle Swarm Optimization (PSO) algorithm, based technique is proposed to estimate and analyze the steady state performance of self-excited induction generator (SEIG). In this novel method the tedious job of deriving the complex coefficients of a polynomial equation and solving it, as in previous methods, is not required. By comparing the simulation results obtained by the proposed method with those obtained by the well known mathematical methods, a good agreement between these results is obtained. The comparison validates the effectiveness of the proposed technique.

Keywords—Evolution theory, MATLAB, Optimization, PSO, SEIG

I. INTRODUCTION

RECENTLY increase in energy demand and limited energy resources in the world caused the researchers to make effort to provide new and renewable energy sources for the usage in an economical and safe way. Besides being clean and of low running cost, renewable energy possesses the privilege of abundance and can be used wherever available. Wind Energy Conversion (WEC) system can feed the generated power directly into the grid or use it to feed an isolated load. Traditionally dc and synchronous generators have been used for stand-alone micro-power system. However due to their construction complexity, high cost and maintenance needed, the induction generator (IG) is proposed as alternatives to the aforementioned generators [1].

The self-excited induction generators (SEIG) have been found suitable for energy conversion for remote locations. Self-excited induction generators (SEIG) are frequently considered as the most economical solution for powering costumers isolated from the utility grid. SEIG has many advantages such as simple construction, absence of DC power supply for excitation, reduced maintenance cost, good over speed capability, and self short-circuit protection capability.

Unlike induction generators connected to the power utility grid, both Frequency and voltage are not fixed but depend on many factors, such as generator parameters, excitation capacitor, speed, and load. This makes the SEIG steady state analysis is more difficult.

To estimate and analyze the performance of a SEIG, researchers have used the conventional equivalent circuit of an induction generator. Gurung K. [2], use the MATLAB symbolic computation technique to model and simulate self excited induction generator. In this technique, the computer

itself carries out both the tedious job of deriving the complex coefficients of the polynomial equations and solving them, M. H. Haque [3], suggested A simple method for analyzing the steady-state performance of a self-excited induction generator with P-Q load model is described, in [4-6] authors used Artificial Neural Network (ANN) to capture the nonlinear magnetization characteristics of induction machine.

In [7] Satnam Mahley suggested a novel method based upon artificial intelligence and natural selection process known as Genetic Algorithm (GA) which mimics the survival of fittest theory. In [8] S Singaravelu, implemented a fuzzy logic approach for the steady state analysis of three phases self excited induction generator with and without series compensation. In this paper we implement a novel method to evaluating the SEIG steady state characteristics, using particle swarm optimization algorithm (PSO) that does not require the detailed derivation of nonlinear equations. After the implementation of the PSO method and comparing its result with the result of the method used in [9], we found our result is so close to them and the PSO method is fast, easy and more accurate.

II. PROBLEM FORMULATION

The SEIG analysis is based on the equivalent circuit of the induction machine shown in Fig.1. The iron loss is neglected and all the parameters are considered constant except the magnetizing reactance which varies according to the saturation characteristics given in appendix A shown in [10].

To analyze the self-excitation process of the induction generator, we implement the nodal admittance method. By applying KVL to circuit of Fig. 1, the sum of admittances of the rotor, magnetizing, and stator branches are equated to zero [11] as in (1).

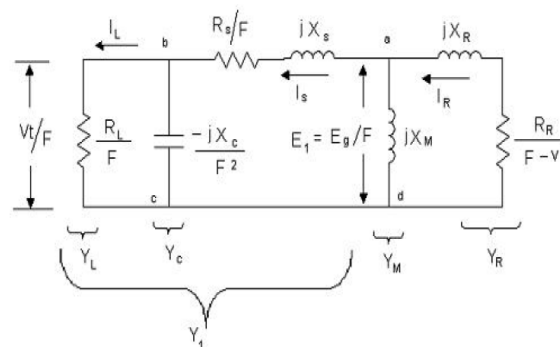

Fig. 1 Per phase nodal admittance equivalent circuit of SEIG

$$E_1 (Y_1 + Y_M + Y_R) = 0 \quad (1)$$

H. E. A. Ibrahim is Associate Professor in Electrical and Computer Control engineering Department at Arab academy for science, technology and marine transport (AAST), Cairo, Egypt.

M. F. Serag is Master student in AAST.

Under normal operating condition, the self-excitation, $E_1 \neq 0$ [10], thus

$$Y_1 + Y_M + Y_R = 0 \quad (2)$$

For given value of shaft speed, generator parameters, excitation capacitance and load impedance, we can determine the value of the p.u. output frequency F and The corresponding value of magnetizing reactance X_M .

R_S, R_R, R_L are the per unit (P.U) stator, rotor and load resistances respectively. X_S, X_R, X_M, X_C is the P.U stator, rotor magnetizing and excitation reactance respectively. Y_S, Y_R, Y_M, Y_L, Y_C are the P.U stator, rotor, magnetizing, load and excitation admittances respectively. F , is the P.U frequency. v , is the P.U speed which is the ratio between rotor speed and synchronous speed. I_S, I_R, I_L , are the P.U stator, rotor and load currents respectively. E_g, V_t , are the P.U air gap and terminal voltage respectively.

III. PSO BASED ON SEIG

To ensure the phenomena of self-excitation, (2) must be satisfied. Equation (2) is solved using PSO method to find the values of unknown F and X_M and then determine the value of the terminal voltage. The objective function of the system to be optimized based on the model of Fig.1 is as follows:

$$\text{Let } Y_1 (Y_1, Y_M, Y_R) = 0 \quad (3)$$

$$\left. \begin{array}{l} \text{Subject to } 0.9 < F < 0.99 \\ 100 < X_M < 200 \end{array} \right\} \quad (4)$$

Where

$$\left. \begin{array}{l} Y_1 = \frac{(Y_C + Y_L)Y_S}{Y_C + Y_L + Y_S} \quad Y_L = \frac{1}{(R_L / F)} \\ Y_M = \frac{1}{jX_M} \quad Y_C = \frac{1}{(-jX_C / F^2)} \\ Y_S = \frac{1}{(R_S / F) + jX_S} \quad Y_R = \frac{1}{\frac{R_R}{F - v} + jX_R} \end{array} \right\} \quad (5)$$

In this system (2-5), the value of the total admittance is considered as fitness function and the problem space is two dimensions F and X_M . Population size is chosen to be 160, the search will be terminated if the number of iterations reaches 200, or if the number of iterations since the last change of the best solution is greater than 51.

The essential steps of the particle swarm optimization can be summarized as shown in the following flowchart Fig. 2,

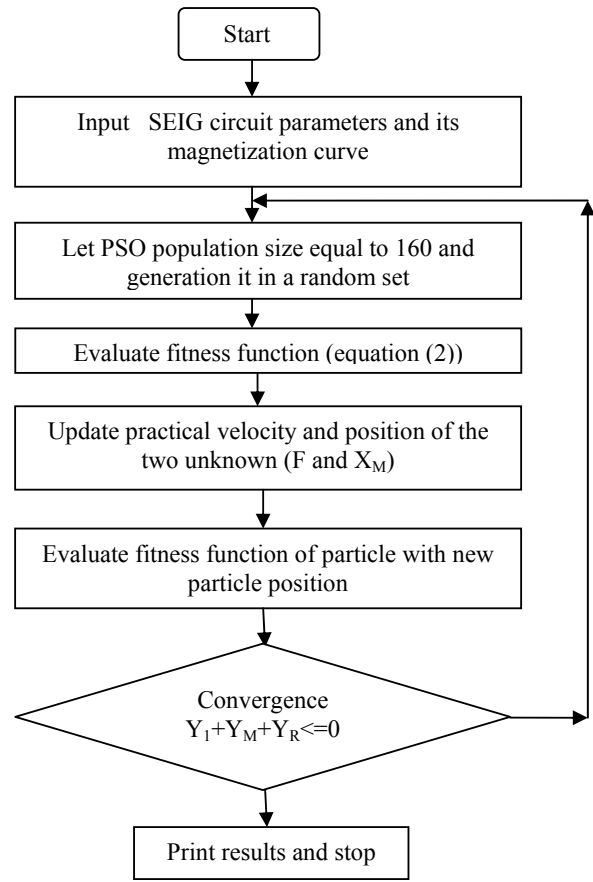

Fig. 2 Flowchart for implementation of PSO

IV. RESULT AND DISCUSSION

Intensive simulation has been done using MATLAB, for PSO algorithm to find the F and X_M , then used to find the terminal voltage (V_t) of the SEIG and other parameter.

The simulation has been run for different capacitance (C), speed (N) and resistive load (R), Table I gives the details of the different values of C, R and N which presented in [10].

TABLE I
THE INPUT DATA (N, C, AND R)

Set No.	Speed RPM		C(μ F)	R(Ω)	No. of Samples
	From	To			
1	1435	1570	36	160	6
2	1275	1435	51	160	6
3	1410	1565	36	220	6
4	1290	1425	51	220	6

We choose the range of speed and the value of terminal capacitance to enable the machine to supply power to the connected load at rated voltage. The resistive load is not sensitive to change in frequency. Therefore, the values of load resistance can be chosen arbitrarily.

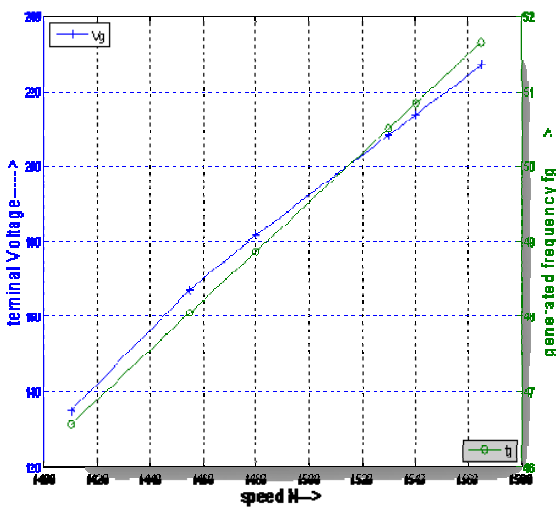

Fig. 3 Voltage and frequency versus Speed at C=36 μ F and R=160 Ω

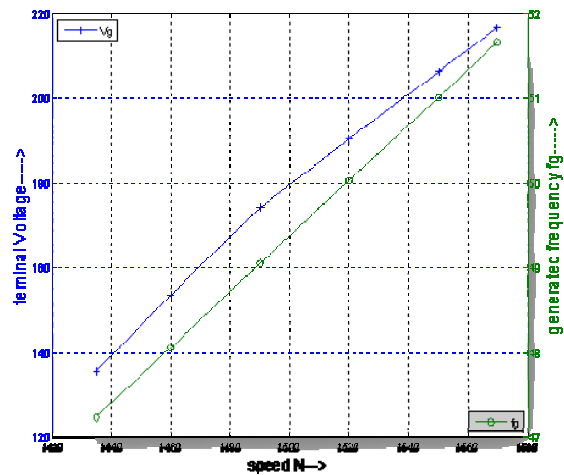

Fig. 4 Voltage and Frequency versus Speed at C=36 μ F and R=220 Ω

Fig. 3 and Fig. 4 shows V_t versus N at C=36 μ F and R=160 Ω and 220 Ω respectively, we used the same input data in [9] to compare our result with them. We get this result after the average cumulative change in value of the fitness function over 50 generations, less than 1e-006 and constraint violation less than 1e-006, after 102 generations.

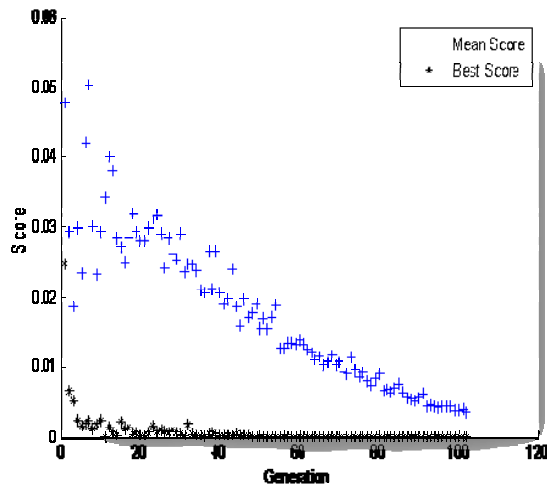

Fig. 5 Best fitness function value versus generation

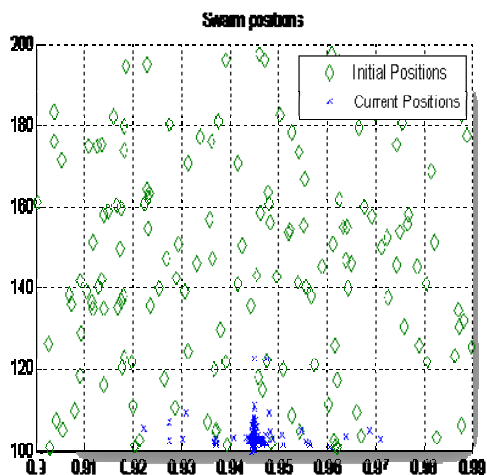

Fig. 6 Initial and current position of the particle swarm

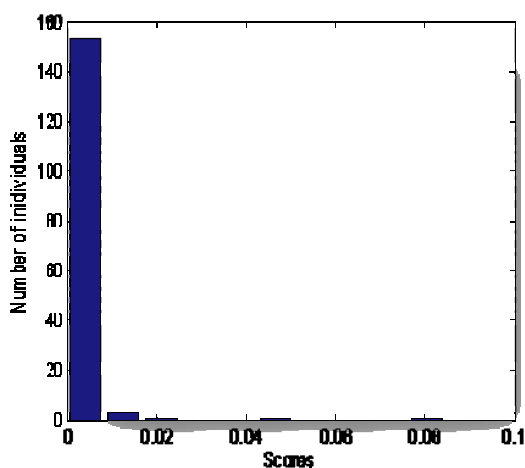

Fig. 7 Number of individuals in each generation

Fig. 5 shows the final best point of the F and X_M which are (1.0333 85.3830) versus the number of the generation stopped at (102 generations).

Fig. 6 shows the initial and final position of the particle swarm position, from the figure the initial position of the particle swarm spread all over the graph but after many iteration the particle swarm settled and cumulative in definite position between 0.94 and 0.95 of the number of initial population range.

Fig. 7 shows a histogram of the scores at each generation. The individual is any point to which one can apply the fitness function.

From the result we found it so close to the result in [9]. Moreover, the PSO method is fast, easy and more accurate than the method in [9].

The various characteristics of the generator can be obtained from its equivalent circuit but that requires running PSO for different possible values of a particular parameter.

V. CONCLUSION

In this paper, novel method (PSO) is proposed to evaluate the performance characteristics of a SEIG as optimization problem. The PSO simulation results are compared with the previous methods results, it is found reliable, more accurate and the closeness between the results prove the validity of PSO technique as a new algorithm to solve the SEIG characteristics.

APPENDIX [10]

Machine Specifications:

3-Phase, 50 Hz, 2.2 kW/3.0 HP, 4-pole, 230 Volts, 8.6 Amp. Delta connected squirrel cage induction machine.

Machine Parameters:

$R_S = 3.35 \Omega$ $R_R = 1.76 \Omega$ $X_S = 4.85 \Omega$
 $X_R = 4.85 \Omega$

Magnetization characteristics of machine for determination of air gap voltage:

$$E_1 = 344.411 - 1.610 X_M \quad X_M < 82.292$$

$$E_1 = 465.120 - 3.077 X_M \quad 95.569 > X_M \geq 82.292$$

$$E_1 = 579.897 - 4.278 X_M \quad 108.00 > X_M \geq 95.569$$

$$E_1 = 0 \quad X_M > 108.00$$

REFERENCES

- [1] M. H. Haque, "A Novel Method of Evaluating Performance Characteristics of a Self-Excited Induction Generator", IEEE Transactions on Energy Conversion, Vol. 24, No. 2, pp.358-365, June 2009.
- [2] Gurung K., Freere P., "MATLAB symbolic computation for the steady state modeling of symmetrically loaded self excited induction generator", Kathmandu university journal of science, engineering and technology, Vol. I, No. III, pp.1-7, January 2007.
- [3] M. H. Haque, "Analysis of a Self-Excited Induction Generator with P-Q Load Model", IEEE Transaction on Energy Conversion, Vol. 25, No. 1, pp.265-267, March 2010.
- [4] D. Joshi, K. S. Sandhu, and M. K. Soni, "Performance Analysis of Self-Excited Induction Generator Using Artificial Neural Network", Iranian Journal of Electrical and Computer Engineering, Vol. 5, No. 1, pp.57-62 Winter-Spring 2006.
- [5] Raja Singh Khela, R. K. Bansal, K. S. Sandhu, and A. K. Goel, "Cascaded ANN for Evaluation of Frequency and Air-gap Voltage of Self-Excited Induction Generator", World Academy of Science, Engineering and Technology 27, pp.301-307, 2007.
- [6] A.A. Arkadan, Y. Abou-Samra, Z.H. Ramadan, "Radial Basis Networks for the Simulation of Stand Alone AC Generators during No-Break Power Transfer", Marquette University, Milwaukee, WI, pp.237-243, 2007.
- [7] S. Mahley, "Steady State Analysis of three phase Self-Excited Induction Generator, Master Thesis, Department of Power Systems and Electric Drives, Thapar University, Patiala, 2008.

- [8] S Singaravelu Dr. S Velusami, "Generalized Steady State Modeling and Analysis of Three Phase Self Excited Induction Generators", International Journal of Emerging Electric Power Systems, Vol. 3, Issue 2, Article 1080, 2005.
- [9] H.E.A.Ibrahim, M.M.Metwaly and M.F.Serag, "Analysis of self excited induction generator (SEIG) using symbolic toolbox and artificial neural network (ANN)", Ain shams journal of electrical engineering (ASJEE), Vol.2, pp.17-28, Dec.2010.
- [10] Raja Singh Khela , Raj Kumar Bansal , K. S. Sandhu and Ashok Kumar Goel, "Application of Artificial Neural Network for Analysis of Self-Excited Induction Generator", JCS and T, Vol. 6, No. 2, pp.73-79, October 2006.
- [11] R.C.Bansal, "Three-Phase Self-Excited Induction Generators: An Overview", IEEE Transactions on Energy Conversion, Vol. 20, No. 2, pp.292-299, June 2005.