

A Green Chemical Technique for the Synthesis of Magnetic Nanoparticles by Magnetotactic Bacteria

Parisa Tajer-Mohammad-Ghazvini, Rouha Kasma-Kermanshahi, Ahmad Nozad-Golikand, and Majid Sadeghizadeh

Abstract—Bacterial magnetic nanoparticles have great useful potential in biotechnological and biomedical applications. In this study, a liquid growth medium was modified for cultivation a fastidious magnetotactic bacterium that has been isolated from Anzali lagoon, Iran in our previous research. These modifications include change in vitamin, mineral, carbon sources and etcetera. In our experience, the serum bottles and designed air-tight laboratory bottles were used to create microaerobic conditions in order to development of a method for scale-up experiment. This information may serve as a guide to green chemistry based biological protocols for the synthesis of magnetic nanoparticles with control over the chemical composition, morphology and size.

Keywords—Green chemistry, Magnetosome, Magnetotactic bacteria, Magnetic nanoparticles, Nano-Biotechnology.

I. INTRODUCTION

MATERIAL science in nanotechnology involves various physical and chemical methods for nanoparticles synthesis. Disadvantage of these methods is the production of toxic byproducts, shows that these are not environmentally safe methods [1].

Synthesis using biological systems is compatible with the green chemistry principles: they are (i) eco-friendly as are (ii) the reducing agent employed and (iii) the capping agent in the reaction [2], [3]. Biogenic nanoparticles involve natural phenomena that take place in the biological systems. Bacteria are considered as the most potent eco-friendly nanofactories [1]. Magnetotactic bacteria (MTB) synthesize unique structures that are called as magnetosomes. Magnetosomes are intracellular membrane-bound nanosized crystals of magnetic iron mineral which consist of magnetite or greigite [4], [5], [6]. MTB's nanoparticles are coated with natural thin organic membrane that confer high and even dispersion in aqueous solutions compared to artificial magnetic nanoparticles, which making them ideal biotechnological materials [7], [8].

P. Tajer-Mohammad-Ghazvini is with Department of Biology, Faculty of Science, Alzahra University, Tehran, Iran, Email (corresponding author): parisa_tajer@yahoo.com

R. Kasma-Kermanshahi is with Department of Biology, Faculty of Science, Alzahra University, Tehran, Iran, Email: rkasra@yahoo.com

A. Nozad-Golikand is with Material School, NSTRI, Tehran, Iran, Email: anozad@gmail.com

M. Sadeghizadeh is with Department of Genetics, Faculty of Biological Science, Tarbiat Modares University, Tehran, Iran, Email: sadeghma@modares.ac.ir

It has already been demonstrated, that isolation and axenic cultivation of MTB in pure culture is very difficult. To date only a small number of isolates is available (and an even smaller number of genera and species) [9], [10]. Recently, pure cultivation of magnetic bacteria in defined medium has provided effective advancement on the application of MTB's nanoparticles. Because MTB's fastidious culture requirements, growths of most of them in on a large scale are difficult so far. Mass cultivation of MTB for magnetosome production is one of the most important biotechnological processes in the application of MTB's nanoparticles [11].

In our previous research we have isolated a curve-shaped magnetotactic bacterium from Anzali lagoon in Gilan province, Iran. In this research we focused on fundamentally new approach for large-scale production of this magnetotactic bacterium. The main goal of this study was development a method with low temperature, lower energy cost and high yield that may make biogenical magnetic nanoparticles a more economical and energy sustainable process than some of the competing processes. Remarkably, it was considered that research in this field because of great potential MTB's nanoparticles in various biotechnological fields from bioremediation processes to medicine would be very useful.

II. MATERIALS AND METHODS

A. Source of Microorganism and Liquid Media Preparation

A curve-shaped magnetotactic bacterium has been isolated during November 2011 from a water/sediment microcosm that was collected from near the oxic-anoxic interface (OAI) from Anzali lagoon in our previous research. After magnetic collection and isolation methods, various minimal and complex media were used for their cultivation experiments. The isolated strain was cultured in the following liquid medium [12], which was optimized during this study. Our modified liquid medium (MLM) contained (per liter deionized water) 1ml wolfe's vitamin solution, 2ml wolfe's mineral solution, 0.5g sodium succinate, 0.1g yeast extract, 0.15g $MgSO_4 \times 7H_2O$, 1.0g peptone casein, 1 mM potassium phosphate buffer (pH 7), 0.1g NH_4Cl , 333.35mg sodium acetate anhydrous, 2mg resazurin, 100 μ M ferric citrate, 0.2g neutralized cystein HCl and the pH was adjusted to 7.0. Neutralized cystein HCl and vitamin elixir were added to the MLM after autoclaving.

B. Development of Methods for Scale-Up Experiment

Fig. 1 shows prototype scale-up experiments from 12ml to 750ml volumes. For this purpose we used of air-tight serum bottles for 12ml and 35ml volumes and air-tight laboratory bottles for 350ml and 750ml volumes. Used air-tight laboratory bottles with aspiration system were designed and built as shown in fig. 2. Cultivation was carried out under microaerobic conditions. Microaerobic gas mixture contained 2% O₂ in 98% N₂. To create microaerobic conditions, bottles with medium were sealed and purged with the microaerobic gas mixture before autoclaving.

C. Electron Microscopy Studies

For electron microscopy, isolated cells of the MTB were diluted by sterilized phosphate buffer solution (pH= 7, 10mM) [14] and then cells were placed on the surface of carbon-coated copper grids. The morphology and configuration of the MTB and their magnetosomes were investigated with an EM 208S transmission electron microscope (Philips) at 100kV.



Fig. 1 The prototype scale-up experiments. (1,2) Images of air-tight serum bottles. (3,4) Images of air-tight laboratory bottles with aspiration system

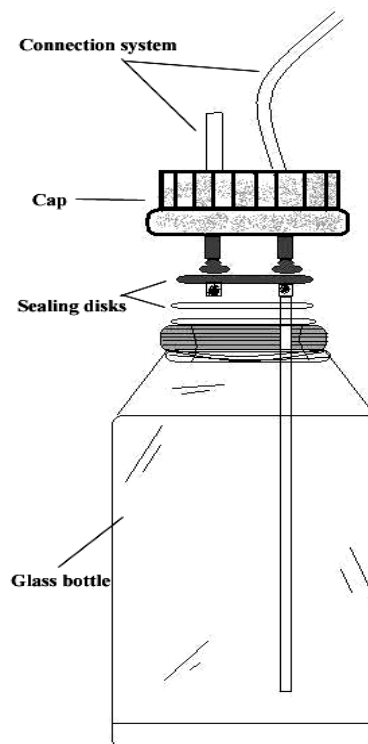

Fig. 2 Connections in an air-tight laboratory bottle

D. Isolation and Purification of Magnetosomes

The magnetotactic bacteria were harvested by centrifugation (8000 rpm, 15 min, 4°C) and washed by sterilized phosphate buffer solution (pH= 7.0). Then the precipitated cells were resuspended in 1N NaOH and boiled for 30 min to lyse the cells [13]. Magnetosomes from the disrupted cells were collected at a graduated cylinder by magnets for 1 h, then the nonmagnetic fluid was removed by aspiration and magnetic nanoparticles washed with buffer. Finally the magnetosomes attracted to the magnet were carefully suspended in sterilized phosphate buffer solution (pH= 7.0).

E. XRD (X-Ray Diffraction) Analysis

Crystalline phase identification of isolated magnetosome were carried out by X-ray diffraction (XRD) using a XRD STOE-STADI MP, Germany with Cu-K α radiation.

III. RESULT AND DISCUSSION

The use of toxic chemicals with physical and chemical methods in the synthesis of nanoparticles limits their biomedical applications. Therefore, development of dependable, nontoxic, and eco-friendly methods for synthesis of nanoparticles is most importance to develop their biomedical and other applications. Use of microorganisms to synthesize nanoparticles is one of the options to achieve this goal [15]. Previous study demonstrated that MTB can form intracellular magnetic nanosized crystals, known as magnetosomes, which are membrane bound and are generally

organized into one or more chains [16], [17]. These innate lipid coatings of magnetosomes due to good disperse in water whereas the synthetic particles need to be rendered water soluble [8]. In addition it is also shown that biological processes can have the ability to strictly control particle morphology but while the control of particle shape in chemical and physical synthesis of nanoparticles is still an ongoing area of research [15]. Despite the ubiquitous occurrence of MTB and their high abundance in aquatic environments, the isolation and cultivation of MTB in pure culture has proven to be very difficult. Because of this, the research in this area has been slow at times [9], [10], [15], [18]. After searching and research, we have isolated a curve-shaped magnetotactic bacterium during November 2011 from Anzali lagoon. As shown in fig. 3, TEM images of unstained cell of the curve-shaped magnetotactic bacterium showed a single chain of magnetosomes. The average sizes of magnetosome crystals per cell are 50-60 nm.

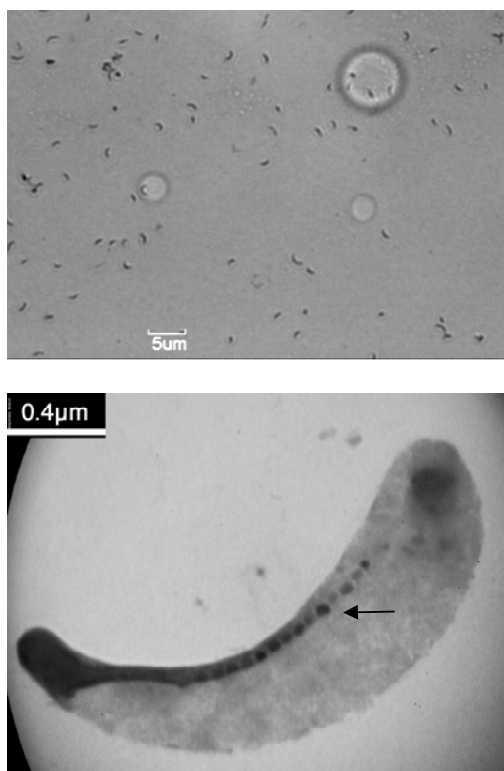

Fig. 3 (a) Light micrograph of the isolated strain cells. For light microscopic imaging, the cells were stained with gram's method and then observed with a digital light microscope (Motic BA310) at magnifications of 1,000x. (b) TEM image of an unstained cell of the isolated strain showed a single chain of magnetosomes, arrow (→) shows chain of magnetosomes inside the magnetotactic bacterium

Since the mass cultivation of MTB for production of bacterial magnetic nanoparticles is one of the important biotechnological processes in the application of the magnetic nanoparticles [10], [19], in this present study, we were studying various liquid growth medium for development of a method for scale-up experiment. As reported in material

method, for this research we used liquid medium [12], which was optimized during this study. These modifications include the following: adding wolfe's vitamin solution, wolfe's mineral solution, sodium succinate, potassium phosphate buffer, resazurin and neutralized cystein HCl, elimination KH_2PO_4 , change in amount of sodium acetate and change in kind of peptone.

Cultivation was carried out under microaerobic conditions and 29°C temperature. Initial studies indicated that optimum growth and magnetosome formation occurred within a narrow range of oxygen concentrations. In order to create this microaerobic condition, we used of air-tight serum bottles and air-tight laboratory bottles (Fig. 1, Fig. 2). Medium were sealed and purged with the microaerobic gas mixture containing 2% O_2 in 98% N_2 before autoclaving. Under this condition, the isolated strain reached comparable final cell densities. The MTB were harvested and magnetosomes were isolated and purified from the cells according as said method in material method. Fig. 4 showing isolated magnetic nanoparticles from this bacterium that can be easily attracted by an applied magnetic field.

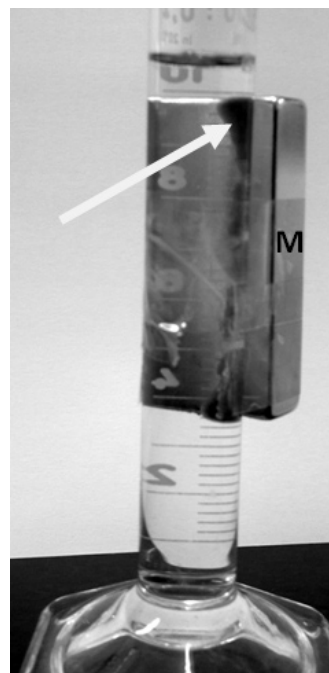

Fig. 4 Photograph of the separation of the isolated magnetic nanoparticles with an external magnetic field (M). Arrow (→) indicates magnetic nanoparticles

As shown in fig. 5, X-ray diffraction studies corroborated that a number of strong reflections were showed the closest match with the standard Fe_3O_4 reflections. This indicated that the magnetic nanocrystal within the magnetosome is consisted of magnetite.

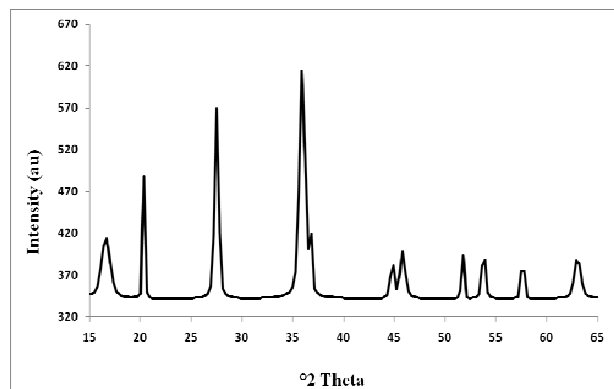

Fig. 5 XRD diffraction patterns of isolated magnetosomes

IV. CONCLUSION

In this work, we report fundamentally new approach for large-scale production of the isolated magnetotactic bacterium. In order to produce enough bacterial magnetic nanoparticles, MTB must be grown in a large optimized culture. The presented results provide the basis for large-scale cultivation of the isolated strain under defined condition. This optimized medium and growth condition in prototype scale-up increased cell and magnetic nanoparticles yields compare with earlier studies. In conclusion, research in development of a method for scale-up experiment of MTB is great remarkable since it could progress our knowledge of mass cultivation of this fastidious bacterium in order to bacterial magnetic nanoparticles production that is one of the most important biotechnological processes in the application of these magnetic nanoparticles.

REFERENCES

- [1] V. Arya, "Living systems: eco-friendly nanofactories," *Digest J. Nanomater. Biostruct.*, vol. 5, pp. 9-21, 2010.
- [2] S. Li, Y. Shen, A. Xie, X. Yu, L. Qui, L. Zhang, and Q. Zhang, "Green synthesis of silver nanoparticles using *Capsicum annum L.* extract," *Green Chem.*, vol. 9, pp. 852-858, 2007.
- [3] T. C. Prathna, T. Lazar Mathew, N. Chandrasekaran, A. M. Raichur, and A. Mukherjee, "Biomimetic synthesis of nanoparticles: science, technology & applicability," in *Biomimetics learning from Nature*. Edited by A. Mukherjee, ISBN number 978-953-307-025-4, IN- TECH Publications, Vienna, Austria, pp. 1-20, 2010.
- [4] D. Schüler, "Formation of magnetosomes in magnetotactic bacteria," *J. Mol. Microbiol. Biotechnol.*, vol. 1, pp. 79-86, 1999.
- [5] D. A. Bazylinski, and R. B. Frankel, "Magnetosome formation in prokaryotes," *Nat. Rev.*, vol. 2, pp. 217-230, 2004.
- [6] D. Schüler, "Molecular analysis of a subcellular compartment: the magnetosome membrane in *Magnetospirillum gryphiswaldense*," *Arch. Microbiol.*, vol. 181, pp. 1-7, 2004.
- [7] T. Matsunaga, and A. Arakaki, "Molecular bioengineering of bacterial magnetic particles for biotechnological applications," In *Magnetoreception and Magnetosomes in Bacteria* (D. Schüler, ed.), Springer, Berlin, Heidelberg, vol. 3, pp. 227-254, 2007.
- [8] J. Xie, K. Chen, and X. Chen, "Production, modification and bio-applications of magnetic nanoparticles gestated by magnetotactic bacteria," *Nano. Res.*, vol. 2, pp. 261-278, 2009.
- [9] D. A. Bazylinski, and T. J. Williams, "Ecophysiology of magnetotactic bacteria," In *Magnetoreception and Magnetosomes in Bacteria* (D. Schüler, ed.), Springer, Berlin, Heidelberg, vol. 3, pp. 37-75, 2007.
- [10] D. Faivre, and D. Schüler, "Magnetotactic Bacteria and Magnetosomes," *Chem. Rev.*, vol. 108, 4875-4898, 2008.
- [11] E. Baeuerlein, "Biomining: From Biology to Biotechnology and Medical Application," Second Edition, Wiley-VCH, ISBN 3-527-31065-7, 2004.
- [12] D. Schüler, and E. Baeuerlein, "Iron-limited growth and kinetics of iron uptake in *Magnetospirillum gryphiswaldense*," *Arch. Microbiol.*, vol. 166, pp. 301-307, 1996.
- [13] C. Yang, H. Takeyama, T. Tanaka, and T. Matsunaga, "Effects of growth medium composition, iron sources and atmospheric oxygen concentrations on production of luciferase-bacterial magnetic particle complex by a recombinant *Magnetospirillum magneticum* AMB-1," *Enzyme. Microb. Technol.*, vol. 29, pp. 13-19, 2001.
- [14] X. Zhijie, L. Bin, C. Jun, and H. H. Teng "Design and application of the method for isolating magnetotactic bacteria," *Chin. J. Geochem.*, vol. 26, pp. 252-258, 2007.
- [15] L. Yan, S. Zhang, P. Chen, H. Liu, H. Yin, and H. Li, "Magnetotactic bacteria, magnetosomes and their application," *Microbiol. Res.*, 2012, in press.
- [16] W. Lin, and Y. Pan, "Temporal variation of magnetotactic bacterial communities in two freshwater sediment microcosms," *FEMS Microbiol. Lett.*, vol. 302, pp. 85-92, 2010.
- [17] D. Schüler, "Genetics and cell biology of magnetosome formation in magnetotactic bacteria," *FEMS Microbiol. Rev.*, vol. 32, pp. 654-672, 2008.
- [18] A. Postec, N. Tapia, A. Bernadac, M. Joseph, S. Davidson, L-F. Wu, B. Ollivier, and N. Pradel, "Magnetotactic bacteria in microcosms originating from the French Mediterranean Coast Subjected to Oil Industry Activities," *Microb. Ecol.*, vol. 63, pp. 1-11, 2012.
- [19] E. Baeuerlein, (ed.) "Biomining: from biology to biotechnology and medical application," Wiley-VCH, Weinheim, Germany, second edition, ISBN 3-527-31065-7, 2000.