

Simulation of Voltage Controlled Tunable All Pass Filter using LM13700 OTA

Bhaba Priyo Das, Neville Watson and Yonghe Liu

Abstract—In recent years Operational Transconductance Amplifier based high frequency integrated circuits, filters and systems have been widely investigated. The usefulness of OTAs over conventional OP-Amps in the design of both first order and second order active filters are well documented. This paper discusses some of the tunability issues using the Matlab/Simulink® software which are previously unreported for any commercial OTA. Using the simulation results two first order voltage controlled all pass filters with phase tuning capability are proposed.

Keywords—All pass filter, Operational Transconductance Amplifier, Simulation.

I. INTRODUCTION

Electronically tunable circuits attracted considerable attention in the design of analog integrated circuits because different values of resistance, inductance or capacitance can be obtained by the same device. Programmability is one the most attractive features of the Operational Transconductance Amplifier (OTA), since this makes it possible to tune analog devices such as; filters, oscillators etc, electronically. OTA is a differential voltage controlled current source (VCCS) where the output current is controlled by an applied input voltage signal. This tunability is obtained by varying the transconductance (g_m) of the OTA which in turn is controlled by the bias current or voltage. However, tunability is restricted by the limited bandwidth of g_m , which depends on the bias current.

OTA is a commercially available active component which has been used widely in many applications. The first example of electronically tunable filter circuit using OTA was proposed in [1]. OTA circuits have been shown to be potentially advantageous for the design of many first and second order high-frequency analog filters [2]–[6]. There is another active component known as Current Conveyor which

provides a wide range of tunability [7] but there is a difference in the internal structure and the OTA uses a lower number of transistors compared to a current conveyor. All pass filters have been exhaustively investigated using OTA particularly, where the design consideration includes phase delay [8]–[9]. This work simulates the commercially available LM13700 OTA using the Matlab/Simulink®. A voltage controlled all pass filter using LM13700 is proposed. Programmability is achieved by using an OTA based floating programmable resistor. Also, a second improved version is obtained by adding the grounded programmable capacitance multiplier [10] which gives it a wider tunable range.

II. OTA FUNDAMENTALS

An ideal OTA is defined by $I_o = g_m (V_{in+} - V_{in-})$ where the input and output resistances are infinite. The transconductance g_m is given by:

$$g_m = \frac{1}{2V_T} I_{bias} \quad (1)$$

where V_T : thermal voltage = 26 mV at room temperature

I_{bias} : bias current.

As voltage is the more easily controllable, a bias circuit is used to convert the voltage to current.

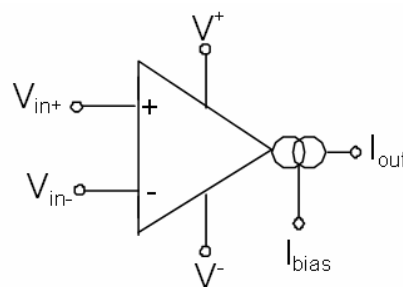

Fig. 1 Circuit symbol of OTA.

A simulink block is created based on the parameters specified in [11] for the commercial LM13700 OTA and the PSPICE model [12] from National Semiconductor. The maximum bias current variation is between 0 to 2 mA.

Bhaba Priyo Das is with the Department of Electrical and Computer Engineering, Univeristy of Canterbury, New Zealand. (Phone: +642102520538; e-mail: bpd21@uclive.ac.nz).

Neville Watson is with the Department of Electrical and Computer Engineering, Univeristy of Canterbury, New Zealand.

Yonghe Liu is with the Department of Electrical and Computer Engineering, Univeristy of Canterbury and School of Information Engineering, Inner Mongolia University of technology, China.

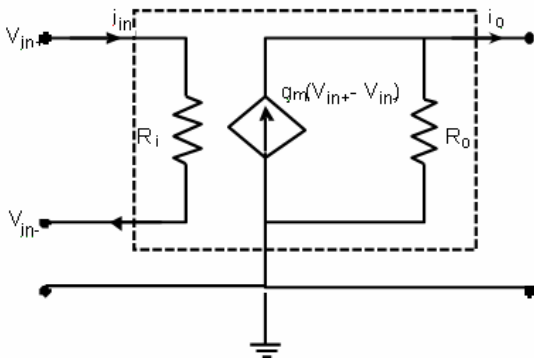

Fig. 2 Small signal model of OTA.

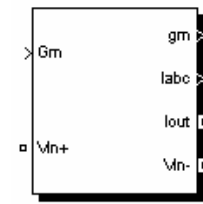

Fig. 3 Developed Simulink model of LM13700.

III. SIMULATION OF FLOATING RESISTOR

Fig. 4 (from [13]) shows the circuit for simulating a floating resistor. Here,

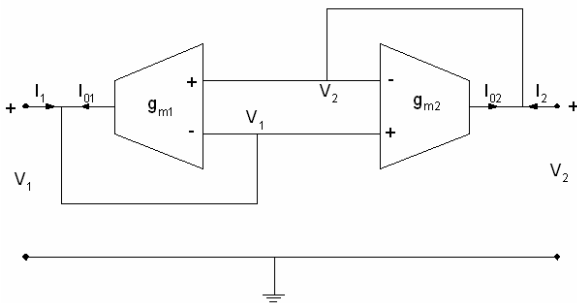

Fig. 4 Circuit for simulating floating resistor.

$$I_{o1} = g_{m1} \times (V_2 - V_1) \quad (2)$$

$$I_{o2} = g_{m2} \times (V_1 - V_2) \quad (3)$$

But, the output currents are:

$$I_{o1} = -I_1 \text{ and } I_{o2} = -I_2$$

$$g_{m1} = g_{m2} = g_m \Rightarrow I_1 = -I_2 \quad (4)$$

Then, effective resistance as seen by terminals at V_1 & V_2 :

$$R_{eff} = \frac{V_1 - V_2}{I_1} = \frac{1}{g_m} \quad (5)$$

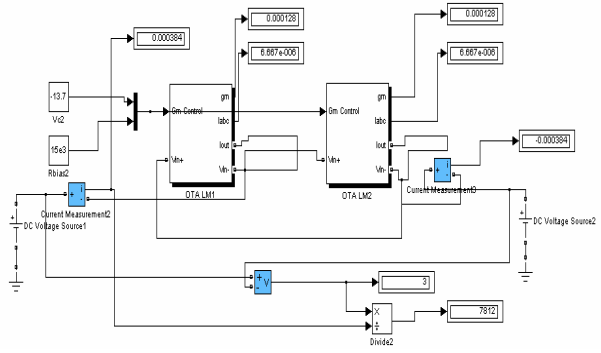

Fig. 5 Simulink model of floating resistor.

Fig.'s 6 and 7 show the variation of bias current with control voltage and variation of effective resistance with control voltage respectively. As can be seen, a wide range of effective resistance can be obtained, from 20 Ω to 7 k Ω .

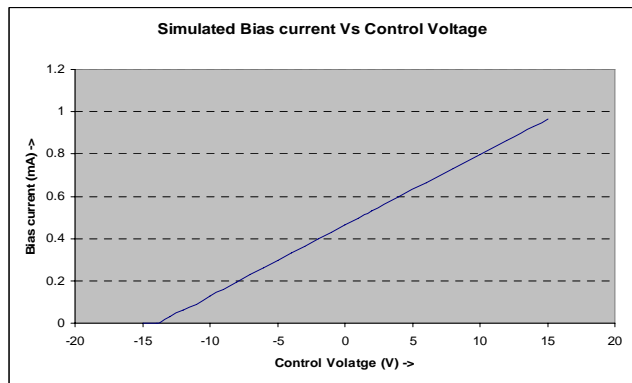

Fig. 6 Variation bias current with control voltage.

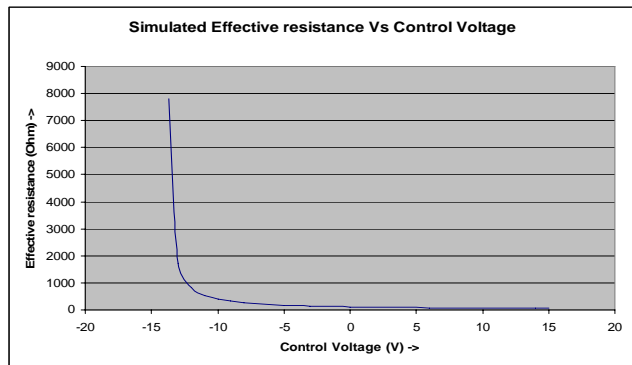

Fig. 7 Variation positive grounded resistance with control voltage.

IV. PROPOSED TUNABLE ALL PASS FILTER

Utilizing the above circuit, the realization of a voltage controlled programmable all pass filter is feasible. The programmable phase shifter proposed is shown in Fig. 8

which utilizes the floating resistor described in section III.

The phase shift between the input and output is given by:

$$\theta = -2 \tan^{-1}(\omega \times R_{eff} \times C) \quad (6)$$

From Section III,

$$R_{eff} = \frac{2 \times V_T}{g_m} = \frac{1}{19.2 \times I_{bias}} \quad (7)$$

where $V_T = 26$ mV at room temperature. From Fig. 6, the equation of the straight line is obtained as:

$$y = 0.0332 x + 0.4638$$

$$y = 0.0332 (x + 13.96)$$

$$y = \frac{1}{2} \times \frac{(x + 13.96)}{15}$$

Again from Fig. 6 it can be seen that at $V_c = -13.9$ V, $I_{bias} = 0$ mA for $R_{bias} = 15$ k Ω . Thus, the relationship between V_c and I_{bias} with R_{bias} in (k Ω), is:

$$I_{bias} = \frac{1}{2} \times \frac{(V_c + 13.96)}{R_{bias}} \text{ mA} \quad (8)$$

From (5)

$$R_{eff} = \frac{1}{g_m} = \frac{1}{19.2 \times I_{bias}} = \frac{2 \times R_{bias}}{19.2 \times (V_c + 13.96)} \quad (9)$$

Substituting (9) into (6) gives the tunable phase shift as:

$$\theta = -2 \tan^{-1}(\omega \times \frac{2 \times R_{bias}}{19.2 \times (V_c + 13.96)} \times C) \quad (10)$$

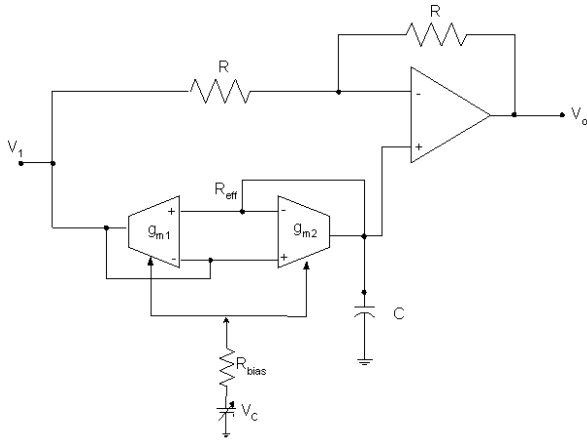

Fig. 8 All pass filter based on floating resistor.

V. SIMULATION RESULTS

The all pass filter was simulated with $R = 10$ k Ω , $C = 1$ μ F for a voltage signal at 1 kHz. The simulation results are in good agreement with the calculated phase shift obtained from (10).

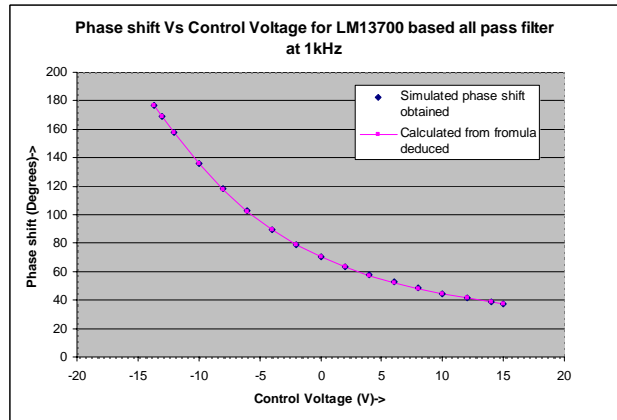

Fig. 9 Simulated and calculated result obtained from circuit of Fig. 8.

VI. GROUNDED CAPACITOR MULTIPLIER [10]

The analysis of the circuit shown in Fig. 10, gives the effective impedance as:

$$Z_{in} = \frac{V}{I_1} = \frac{1}{sC \times \frac{g_{m1}}{g_{m0}}} \quad (11)$$

From (11), effective capacitance is:

$$C_{eff} = C \times \frac{g_{m1}}{g_{m0}} = C \times \frac{I_{bias1}}{I_{bias0}} = C \times \frac{V_{c1} + 13.96}{V_{c0} + 13.96} \quad (12)$$

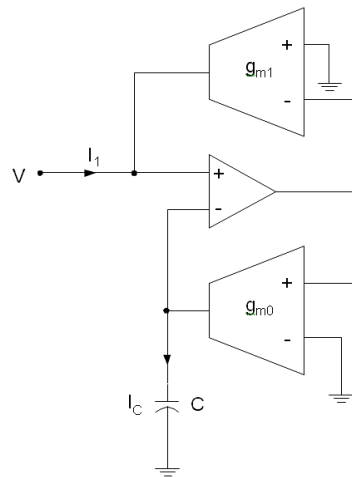

Fig. 10 Circuit for simulating grounded Capacitor.

VII. MODIFIED ALL PASS FILTER

Incorporating the grounded capacitor multiplier in circuit, the realization of a voltage controlled programmable floating resistor and a programmable grounded capacitor is depicted in Fig. 12. The equation for phase shift is now, given by:

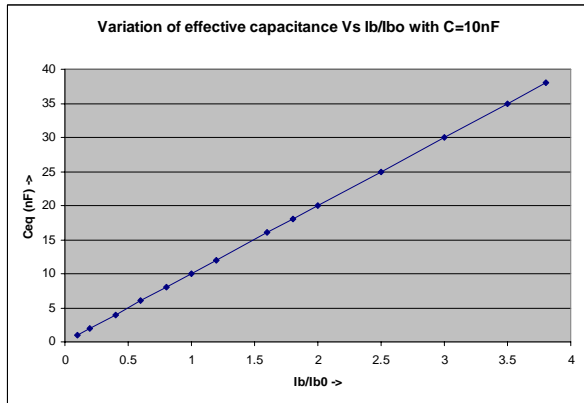

Fig. 11 Variation of effective capacitance for grounded Capacitor with $I_{bias0} = 500 \mu A$. I_{bias1} varied from $50 \mu A$ to $2 mA$ and $C = 10 nF$.

Substituting (12) in (10) gives:

$$\theta = -2 \tan^{-1} \left(\omega \times \frac{2 \times R_{bias}}{19.2 \times (V_c + 13.96)} \times \frac{V_{c1} + 13.96}{V_{c0} + 13.96} \times C \right) \quad (13)$$

Keeping $I_{bias0} = 500 \mu A$ i.e $V_{c0} = -6.4 V$ fixed

$$\theta = -2 \tan^{-1} \left(\omega \times \frac{2 \times R_{bias}}{19.2 \times (V_c + 13.96)} \times \frac{V_{c1} + 13.96}{7.5} \times C \right)$$

$$\theta = -2 \tan^{-1} \left(\omega \times \frac{2 \times R_{bias}}{19.2 \times (V_c + 13.96)} \times G \times C \right) \quad (14)$$

The all pass filter is simulated with $R = 10 k\Omega$, $C = 1 \mu F$ for a voltage signal at $1 kHz$. The phase shift variation is from 38° to 177° for V_c variation from $15 V$ to $-13.7 V$ for circuit in Fig. 12. Using $G = 0.25$ i.e $V_{c1} = 12 V$, a wider tunable phase shift is obtained as shown in Fig. 13.

It is evident from Fig. 13 that for same control voltage, a wider phase shift from 10° to 176° is obtained in the proposed circuit as compared to the one in Fig. 8 where the lower limit starts at 38° for a $1 kHz$ signal. This wider phase shift variation has been obtained due to the grounded capacitance multiplier added in the circuit of Fig. 8. This circuit has been simulated for $100 Hz$, $1 kHz$ and $10 kHz$.

VIII. CONCLUSION

In this paper, electronically tunable resistors and capacitors are simulated in MATLAB/Simulink® using the LM13700 model developed. Both grounded and floating configurations are discussed. Tunability issues for these circuits with respect to the control voltage are presented. Most of these follow an exponential relation with the control voltage. A simple voltage controlled all pass filter is proposed where the phase shift depends on the applied control voltage.

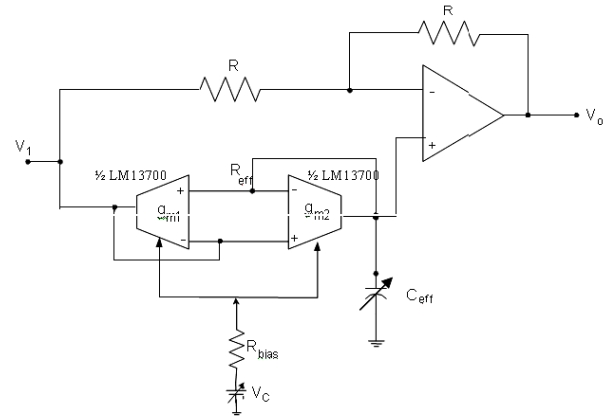

Fig. 12 Proposed modified wider tunable all pass filter.

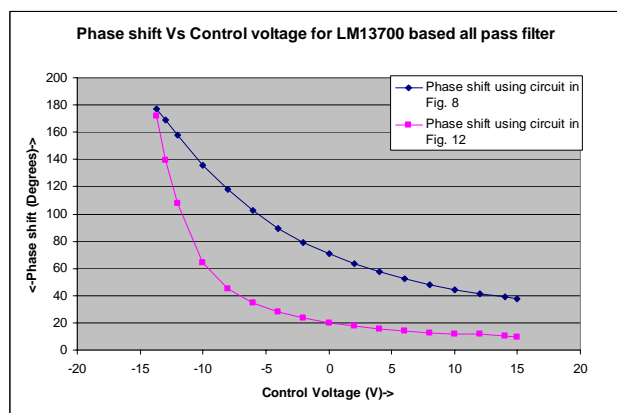

Fig. 13 Comparison of simulation results for the proposed circuit and the circuit in Fig. 8.

The electronically tunable grounded capacitance multiplier using two OTAs and one Op-Amp is used. This configuration is capable of both enhancement and attenuation gains. Based on this capacitance multiplier, the simple all pass filter proposed here obtains a wider phase shift. A continuous phase can be obtained with a proper choice of capacitance and biasing resistance.

REFERENCES

- [1] S. Franco, "Use transconductance amplifier to make programmable active filters". *Electronic Design*, 24(19), 1976, pp. 98–101.
- [2] R. L. Geiger, E. Sanchez - Sinencio, "Active filter design using operational transconductance amplifiers: A tutorial", *IEEE Circuits and Devices Magazine*, 1, 1985, pp. 20–32.
- [3] A. Urbas, J. Osowski, "High-frequency realization of C-OTA second-order active filters", *Proceedings of International Symposium on Circuits and Systems (ISCAS)*, 3, 1982, pp. 1106–1109.
- [4] H. Malvar, "Electronically controlled active filters with operational transconductance amplifiers", *IEEE Transactions on Circuits and Systems*, CAS-29, 1982, pp. 333–336.
- [5] T. Deliyannis, Y. Sun, & J. K. Fidler, *Continuous time active filter design* Boca Raton: CRC Press, 1999, Ch-8.
- [6] Y. Sun, *Design of high frequency integrated analogue filters*. London: IEE Press, 2002.

- [7] A. J. Martin, J. Ramirez-Angulo, R. G. Carvajal, "Design of high-performance tunable filters based on current conveyors", Proceedings of 2005 European Conference on Circuit theory and design, Vol. 2, 2005, pp. II/103-II/106.
- [8] N. A. Shah, S. N. Ahmad, "Electronically tunable OTA-based all-pass circuit", *International Journal of Electronics*, 68(6), 1990, pp. 963–966.
- [9] M. Abuelmaati, U. Baroudi, "A programmable phase shifter for sinusoidal signals", *Active and Passive Electronic Components Journal*, Vol. 21, 1998, pp.107-112.
- [10] M. T. Ahmed, I. A. Khan and N. Minhaj, "Novel electronically tunable C-multipliers," *Electronics letters*, vol. 31, no. 1, 1995, pp. 9-11.
- [11] *Datasheet- LM13700 Dual Operational Transconductance Amplifiers with linearizing diodes and buffers*. National Semiconductor, 2004.
- [12] www.national.com/models/spice/LM/LM13700.MOD
- [13] Kendall. Su, *Analog Filters*, Kluwer Academic Publishers, 2003, Ch-14.