

Motion Control of TUAV having Eight Rotors for Enhanced Situational Awareness

Igor Astrov and Andrus Pedai

Abstract—This paper focuses on a critical component of the situational awareness (SA), the control of autonomous vertical flight for tactical unmanned aerial vehicle (TUAV). With the SA strategy, we proposed a two stage flight control procedure using two autonomous control subsystems to address the dynamics variation and performance requirement difference in initial and final stages of flight trajectory for a nontrivial nonlinear eight-rotor helicopter model. This control strategy for chosen model of mini-TUAV has been verified by simulation of hovering maneuvers using software package Simulink and demonstrated good performance for fast stabilization of engines in hovering, consequently, fast SA with economy in energy of batteries can be asserted during search-and-rescue operations.

Keywords—Flight control, eight-rotor helicopter, situational awareness, tactical unmanned aerial vehicle

I. INTRODUCTION

SITUATION awareness has been formally defined as “the perception of elements in the environment within a volume of time and space, the comprehension of their meaning, and the projection of their status in the near future” [1]. As the term implies, situation awareness refers to awareness of the situation. Grammatically, situational awareness (SA) refers to awareness that only happens sometimes in certain situations.

SA has been recognized as a critical, yet often elusive, foundation for successful decision-making across a broad range of complex and dynamic systems, including emergency response and military command and control operations [2].

The term SA have become commonplace for the doctrine and tactics, and techniques in the U.S. Army [3]. SA is defined as “the ability to maintain a constant, clear mental picture of relevant information and the tactical situation including friendly and threat situations as well as terrain”. SA allows leaders to avoid surprise, make rapid decisions, and choose when and where to conduct engagements, and achieve decisive outcomes.

Manuscript received August 5, 2011. This work was supported in part by the Ministry of Education and Research of Estonia under Project SF0140113As08.

I. Astrov is with the Department of Computer Control, Tallinn University of Technology, Tallinn 19086, Estonia (corresponding author to provide phone: 372-620-2113, fax: 372-620-2101; e-mail: igor.astrov@dcc.ttu.ee).

A. Pedai is with the Department of Computer Control, Tallinn University of Technology, Tallinn 19086, Estonia (e-mail: andrus.pedai@dcc.ttu.ee).

The tactical unmanned aerial vehicle (TUAV) is one of the key tools to gather the information to build SA for all leaders. The TUAV is the ground maneuver commander's primary day and night system. The TUAV provides the commander with a number of capabilities including:

- Enhanced SA.
- Target acquisition.
- Battle damage assessment.
- Enhanced battle management capabilities (friendly situation and battlefield visualization).

The combination of these benefits contributes to the commander's dominant SA allowing him to shape the battlefield to ensure mission success and to maneuver to points of positional advantage with speed and precision to conduct decisive operations. Some conditions for conducting aerial reconnaissance with TUAVs are as follows.

- Time is limited or information is required quickly.
- Detailed reconnaissance is not required.
- Extended duration surveillance is not required.
- Target is at extended range.
- Threat conditions are known; also the risk to ground assets is high.
- Verification of a target is needed.
- Terrain restricts approach by ground units.

A mini-TUAV offers many advantages, including low cost, the ability to fly within a narrow space and the unique hovering and vertical take-off and landing (VTOL) flying characteristics.

The current state of TUAVs throughout the world is outlined [4]. A novel design of a multiple rotary wing platform which provide for greater SA in the urban terrain is then presented.

Autonomous vertical flight is a challenging but important task for TUAVs to achieve high level of autonomy under adverse conditions. The fundamental requirement for vertical flight is the knowledge of the height above the ground, and a properly designed controller to govern the process.

In [5], a three stage flight control procedure using three autonomous control subsystems for a nontrivial nonlinear helicopter model on the basis of equations of vertical motion for the center of mass of helicopter was proposed. The proposed control strategy has been verified by simulation of hovering maneuvers using software package Simulink and demonstrated good performance for fast SA.

This paper concentrates on issues related to the area of [5], but demonstrates another field for application of these ideas, i.e., research technique using control system modeling and simulation on the basis of equations of motion for the center of mass of unmanned eight-rotor helicopter for fast SA.

In this paper our research results in the study of vertical flight (take-off and hovering cases) control of unmanned eight-rotor helicopter which make such SA task scenario as "go-search-find-return" possible are presented.

The contribution of the paper is twofold: to develop new schemes appropriate for SA enhancement using UAVs by hybrid control of vertical flight of autonomous eight-rotor helicopters in real-time search-and-rescue operations, and to present the results of hovering maneuvers for chosen model of the eight-rotor helicopter for fast SA in simulation form using the MATLAB/Simulink environment.

II. EIGHT-ROTOR TUAV MODEL

In [6], an original configuration of a multicopter composed of eight rotors was proposed. Four rotors, also called main rotors, are used to stabilize the attitude of the helicopter, while the four extra rotors (lateral rotors) are used to perform the lateral movements of the helicopter. In order to avoid the yaw drift due to the reactive torques, the main rotors are such that the right and left rotors rotate clockwise while the front and rear rotors rotate counterclockwise. Similarly the external lateral motors located on the same axis rotate in opposite directions to avoid interacting with the roll and pitch displacements.

In practice, this eight-rotor helicopter is able to perform vertical take-off and landing, hovering and translational flight. The main advantage of the proposed eight-rotor helicopter with respect to a four-rotor helicopter is that the attitude dynamics is decoupled from the translational dynamics. Indeed, four-rotor rotorcrafts must tilt in order to move forward. This implies that the rotational and translational movements are coupled.

If the eight-rotor helicopter [6] assumed to move at low speed, the translational dynamic become

$$\ddot{x} = \frac{(\cos\theta \cos\psi)u_x}{m} + \frac{(\cos\psi \sin\theta \sin\phi - \cos\phi \sin\psi)u_y}{m} + \frac{(\cos\phi \cos\psi \sin\theta + \sin\phi \sin\psi)u_z}{m} \quad (1)$$

$$\ddot{y} = \frac{(\cos\theta \sin\psi)u_x}{m} + \frac{(\sin\theta \sin\phi \sin\psi + \cos\phi \cos\psi)u_y}{m} + \frac{(\cos\phi \sin\theta \sin\psi - \cos\psi \sin\phi)u_z}{m} \quad (2)$$

$$\ddot{z} = \frac{(-\sin\theta)u_x}{m} + \frac{(\cos\theta \sin\phi)u_y}{m} + \frac{(\cos\theta \cos\phi)u_z}{m} - g \quad (3)$$

where

x, y, z are coordinates of center of mass in the earth-frame;

ϕ, θ, ψ are roll, pitch and yaw angles;

g is the gravity constant;

m is the mass of the helicopter;

u_x, u_y, u_z are the control inputs.

For simplicity and obvious reasons for the translational dynamics, we choose the angle α between the main rotor axis and the lateral rotor axis so as $\alpha = 90^\circ$.

The inputs in (1)-(3) are defined as

$$u_x = f_5 - f_7 \quad (4)$$

$$u_y = f_8 - f_6 \quad (5)$$

$$u_z = f_1 + f_2 + f_3 + f_4 + f_9 + f_{10} + f_{11} + f_{12} \quad (6)$$

where $f_i (i = 1, \dots, 8)$ is the thrust force of rotor i .

There exist additional forces f_9 to f_{12} acting on each one of the four main rotors. These forces are due to the airflow generated by the lateral rotors. Considering identical lateral motors, forces f_9 to f_{12} can be expressed as follows

$$f_9 = bf_5, f_{10} = bf_6, f_{11} = bf_7, f_{12} = bf_8 \quad (7)$$

Introducing (7) in (6), we obtain

$$u_z = f_1 + f_2 + f_3 + f_4 + b(f_5 + f_6 + f_7 + f_8) \quad (8)$$

We notice that the thrust forces of each rotor i can be expressed in the form [7]

$$f_i = K_T \omega_i^2, \quad (9)$$

where

ω_i is the angular speed of rotor $i (i = 1, \dots, 8)$,

$$K_T = 10^{-5} \text{Ns}^2.$$

It is now seen that the angular speed ω_i of rotor i simplifies to:

$$\omega_i = 2\pi \frac{n_{m_i}}{60} \approx \frac{n_{m_i}}{10} \quad (10)$$

where n_{m_i} (rpm) is the number of revolutions per minute of rotor i .

Combining (9) and (10), we have

$$n_{m_i} \approx 10 \sqrt{\frac{f_i}{K_T}} \quad (11)$$

As the aerodynamic friction torque and the gyroscopic torque are neglected in this model at low speed, then the rotational dynamic of the eight-rotor rotorcraft is given by [6]

$$JW\ddot{\eta} + J\dot{W}\dot{\eta} + W\dot{\eta} \times JW\dot{\eta} = \tau \quad (12)$$

where

$$\tau = (\tau_1, \tau_2, \tau_3)^T,$$

$$\tau_1 = f_1 - f_2 + f_3 - f_4, \tau_2 = l_c(f_2 - f_4) + bu_x, \tau_3 = l_c(f_1 - f_3) + bu_y, \quad (13)$$

$$\eta = (\psi, \theta, \phi)^T,$$

$$W = \begin{bmatrix} 0 & -\sin \psi & \cos \psi \cos \theta \\ 0 & \cos \psi & \sin \psi \cos \theta \\ 1 & 0 & -\sin \theta \end{bmatrix},$$

$$\dot{W} = \begin{bmatrix} 0 & -\dot{\cos \psi} & -\dot{\cos \psi} \sin \theta - \dot{\cos \theta} \sin \psi \\ 0 & -\dot{\sin \psi} & -\dot{\sin \psi} \sin \theta + \dot{\cos \theta} \cos \psi \\ 0 & 0 & -\dot{\cos \theta} \end{bmatrix},$$

l_c is the distance from the centre of mass to any internal rotor,

J is the inertia matrix.

The equations (4), (5), (8) and (13) then can be represented in matrix form as

$$\begin{bmatrix} u_x \\ u_y \\ u_z \\ \tau_1 \\ \tau_2 \\ \tau_3 \end{bmatrix} = \begin{bmatrix} 0 & 0 & 0 & 0 & 1 & 0 & -1 & 0 \\ 0 & 0 & 0 & 0 & 0 & -1 & 0 & 1 \\ 1 & 1 & 1 & 1 & b & b & b & b \\ 1 & -1 & 1 & -1 & 0 & 0 & 0 & 0 \\ 0 & l_c & 0 & -l_c & b & 0 & -b & 0 \\ l_c & 0 & -l_c & 0 & 0 & -b & 0 & b \end{bmatrix} \begin{bmatrix} f_1 \\ f_2 \\ f_3 \\ f_4 \\ f_5 \\ f_6 \\ f_7 \\ f_8 \end{bmatrix} \quad (14)$$

Note that exists an orientation of body frame in which the inertia matrix in (12) simplifies to:

$$J = \text{diag}(I_x, I_y, I_z) \quad (15)$$

For simplicity we consider the matrix J in (15) as unit matrix, i.e.

$$J = \text{diag}(1,1,1), \quad (16)$$

where $I_x = I_y = I_z = 1 \text{kgm}^2$.

Substituting (16) into (12), we obtain

$$W \ddot{\eta} + \dot{W} \dot{\eta} + W \dot{\eta} \times W \dot{\eta} = \tau \quad (17)$$

If we apply the properties of vector product to (17), we obtain

$$W \ddot{\eta} + \dot{W} \dot{\eta} = \tau \quad (18)$$

From (18), we have

$$\ddot{\eta} = W^{-1} \tau - W^{-1} \dot{W} \dot{\eta} \quad (19)$$

where

$$W^{-1} = \frac{1}{\cos \theta} \begin{bmatrix} \cos \psi \sin \theta & \sin \psi \sin \theta & \cos \theta \\ -\sin \psi \cos \theta & \cos \psi \cos \theta & 0 \\ \cos \psi & \sin \psi & 0 \end{bmatrix}.$$

We can regroup the three dynamics in (19) as:

$$\ddot{\psi} = \dot{\theta} \dot{g} \theta + \dot{\phi} \sec \theta + \tau_1 \dot{g} \theta \cos \psi + \tau_2 \dot{g} \theta \sin \psi + \tau_3 \quad (20)$$

$$\ddot{\theta} = -\dot{\phi} \cos \theta - \tau_1 \sin \psi + \tau_2 \cos \psi \quad (21)$$

$$\ddot{\phi} = \dot{\theta} \sec \theta + \dot{\theta} \dot{g} \theta + \tau_1 \cos \psi \sec \theta + \tau_2 \sin \psi \sec \theta \quad (22)$$

From (1)-(3), (20)-(22) we can see that the attitude vector $(x, y, z)^T$ for given model of eight-rotor UAV can be computed.

The numerical values for parameters of (1)-(3), (20)-(22) for a case of small elevation above sea level are given by [8]:

$$b = 0.64, m = 1.2 \text{kg}, l_c = 0.25 \text{m}, g = 9.81 \text{m/s}^2.$$

III. CONTROL SYSTEM

It is possible to consider the thrusts f_1 and f_2 in (8) as equal constants, and to consider the thrust f_7 in (4), (8) as fixed constant, and to consider the thrusts f_5, f_6, f_8 in (4), (5), (8) as identical zero, and to equalize thrust f_3 to thrust f_4 in (8). Hence, we have

$$f_1(t) = f_2(t) = \text{const} \quad (23)$$

$$f_3(t) = f_4(t) \quad (24)$$

$$f_5(t) = f_6(t) = f_8(t) = 0 \quad (25)$$

$$f_7(t) = \text{const} \quad (26)$$

Hence, from (13), (23) and (24), we find

$$\tau_1 = 0 \quad (27)$$

Combining (4), (13) and (23)-(25), we can write

$$\tau_2 = 2l_c f_1 + \frac{b(l_c - 2)}{2} f_7 - \frac{l_c}{2} u_z \quad (28)$$

Then, from (5), (13) and (23)-(25), it follows that

$$\tau_3 = 2l_c f_1 + \frac{bl_c}{2} f_7 - \frac{l_c}{2} u_z \quad (29)$$

Combining (4)-(5) and (25)-(26), we have

$$u_x = -f_7 \quad (30)$$

$$u_y = 0 \quad (31)$$

With selection of (30)-(31), a complex control problem is now turned into a control problem with using only one collective thrust u_z as control input for controlling the coordinate z of altitude with respect to reference input z^0 .

The control system configuration to regulate the input variable u_z is thus designed, to have the next structure (see Fig. 1)

$$\dot{u}_z = K(t_1(z^0 - z) - t_2 \dot{z} - \ddot{z}) \quad (32)$$

where t_1, t_2 are constants to be determined.

It is possible to consider the variable u_z as a "fast" function of time. Hence, assuming that $\dot{u}_z \approx 0$, from (32), we find

$$\ddot{z} + t_2 \dot{z} + t_1 z = t_1 z^0 \quad (33)$$

The following coefficients of (33) are obtained from [9], for overshooting with value of $\sigma \approx 5\%$

$$t_1 \approx \frac{9}{t_{dz}^2}, t_2 \approx \frac{3\sqrt{2}}{t_{dz}} \quad (34)$$

where t_{dz} is desired transition time of coordinate z .

For a hovering flight, angles of roll, pitch, and yaw must be zeros. Therefore, it follows from (3) that

$$\ddot{z} = cu_z(t) - g \quad (35)$$

where

$$c = \frac{1}{m}. \quad (36)$$

Differentiating both sides of (35) with respect to time, we obtain

$$\dddot{z}(t) = c\dot{u}_z(t) \quad (37)$$

Combining (32) and (37), we have

$$\ddot{z}(t) = cK(i_3(t) - \ddot{z}(t)), \quad (38)$$

where

$$i_3(t) = t_1(z^0 - z(t)) - t_2\dot{z}(t). \quad (39)$$

Defining $\ddot{z}(t) = a(t)$ in (38), we obtain

$$\dot{a}(t) = cKi_3(t) - cKa(t) \quad (40)$$

The variable $a(t)$ in (40) can be described in a common way through next expression as indicated in [10]

$$a(t) = (a_0 + \int_0^t e^{-A(\tau)} cKi_3(\tau) d\tau) e^{A(t)}, \quad (41)$$

where

$$A(t) = -\int_0^t cKd\tau. \quad (42)$$

Let us consider the behavior of the considered control system (see Fig. 1) for the time t of time interval $t \geq t_{dz}$ during the hovering.

Hence, assuming that $a_0 = 0$, $z^0 - z(t) \approx \Delta z^0$, $\Delta = 0.05$, $\dot{z}(t) \approx 0$, from (41)-(42), we find

$$a(t) = i_3(1 - e^{-cKt}) \quad (43)$$

where

$$i_3(t) \approx t_1\Delta z^0 \approx const. \quad (44)$$

Assume now that for the desired transition time for control of acceleration $a(t)$ lies in the zone of overshooting with value of $\sigma \approx 5\%$, then, from (43)-(44), it follows that

$$t_{dz} \approx -\frac{\ln(\Delta)}{cK} \quad (45)$$

Therefore, using (36) and (45), and the ratio of coordinate-to-acceleration transition times $N = \frac{t_{dz}}{t_{dz}}$ and that $\ln(\Delta) \approx -3$,

we obtain

$$K \approx \frac{3Nm}{t_{dz}} \quad (46)$$

IV. SIMULATION RESULTS

Consider the control of eight-rotor TUAV model (1)-(3), (20)-(22) for the case of take-off and hovering maneuvers by hybrid constrained system of two control subsystems.

The goal of the following simulations is twofold. First, we verify that these control subsystems are able to control the take-off and hovering trajectories. Second, we observed the effect of enhancing SA because the variety of such trajectory parameters as constant thrust forces of the first, second and seventh rotors, initial conditions, desired height positions, ratios of coordinate-to-acceleration transition times and desired transition times for control subsystems easily can be changed the possible take-off and hovering trajectories of eight-rotor TUAV.

These trajectory parameters are chosen to be:

$$f_1 = f_2 = 4.2N, f_7 = 1N, x(0) = y(0) = z(0) = 0m,$$

$$z_1^0 = 2m, z_2^0 = 10m, N_1 = 40, N_2 = 20, t_{d1} = 2s, t_{d2} = 15s.$$

Simulation results of the offered block scheme with two control subsystems (see Fig. 1) are shown in Figs. 4-7.

The constant number of revolutions per minute of rotors 1 and 2 is equal to $6481rpm$, and of rotor 7 is equal to $3163rpm$. The behaviour of numbers of revolutions per minute of rotors 3 and 4 is shown in Fig. 2.

Fig. 3 shows the height trajectory of flight control. We simulated the block diagrams of subsystems as parts of hybrid control system and take into account that the full take-off and hovering trajectories were separated into initial and final phases with boundary point in the first lag position.

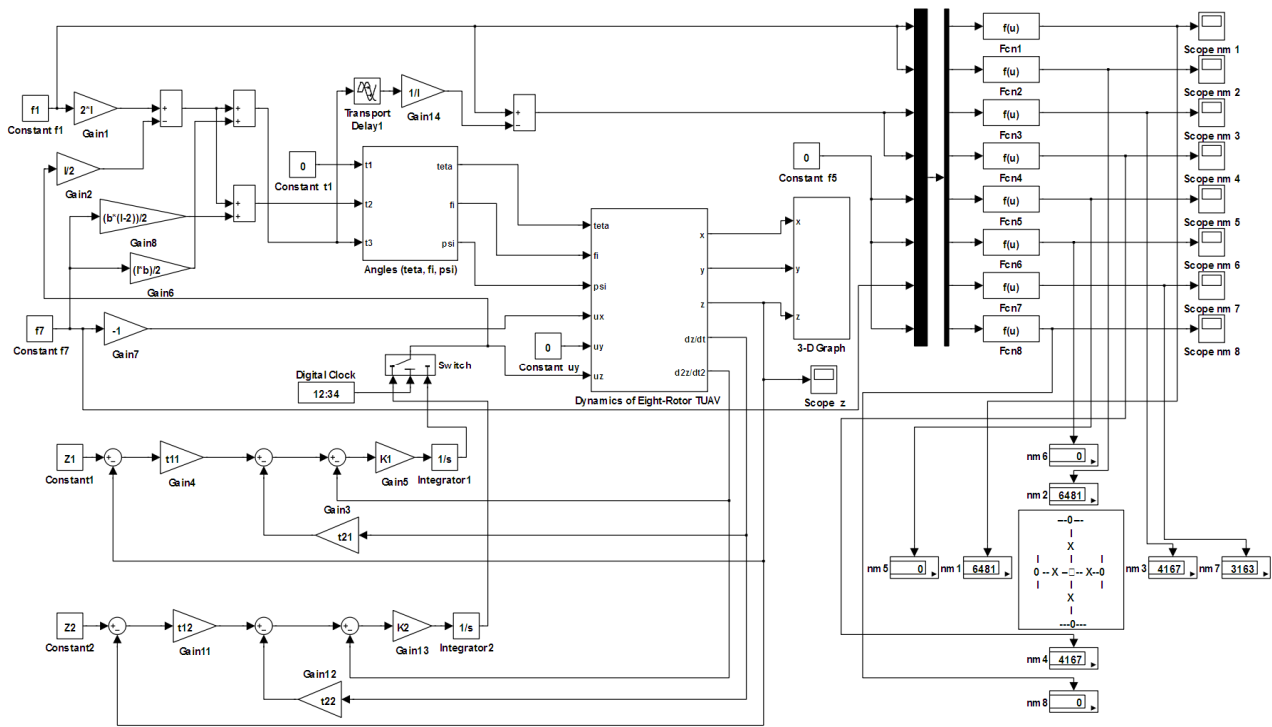

Fig. 1 Block diagram of hybrid control system

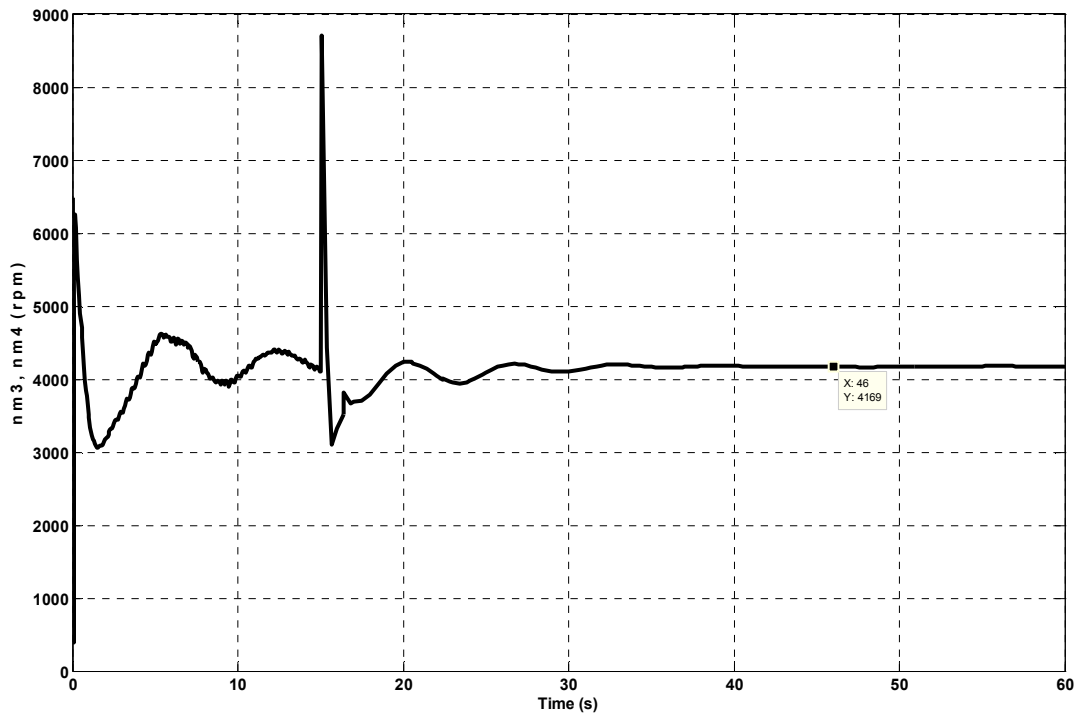

Fig. 2 Numbers of revolutions per minute of rotors 3 and 4.

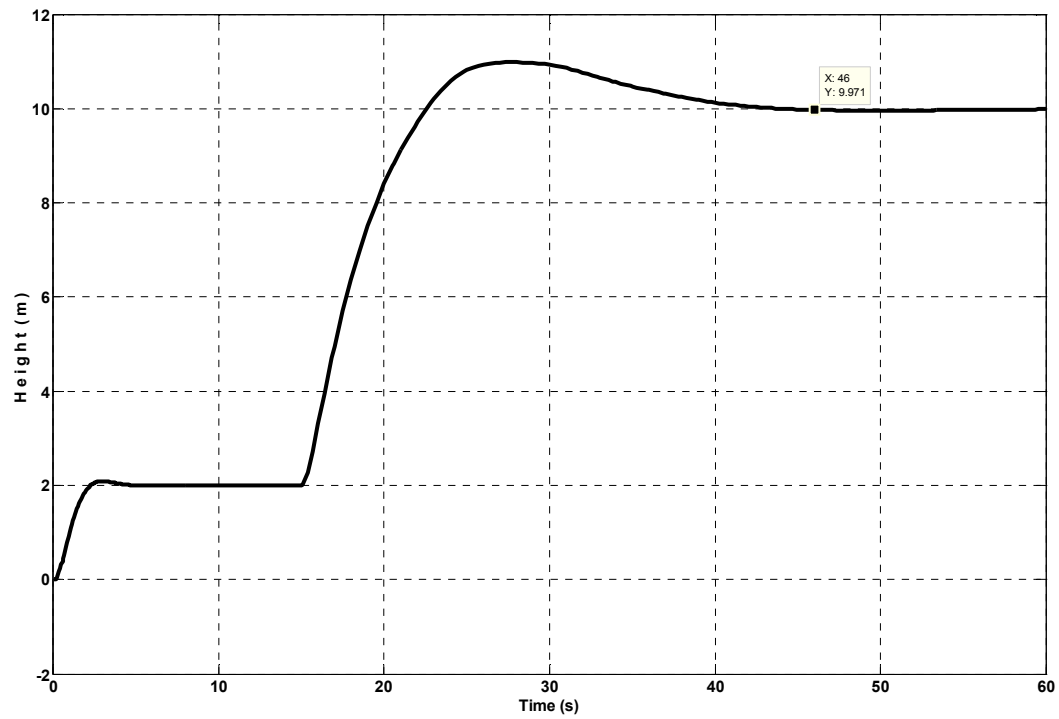

Fig. 3 Height trajectory of eight-rotor TUAV

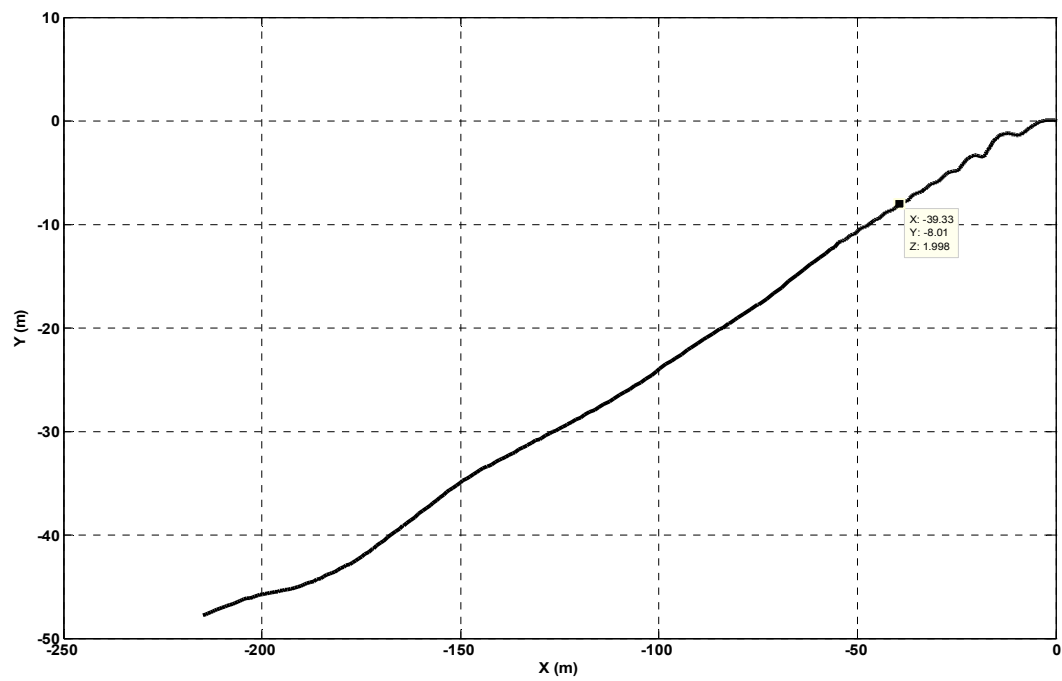

Fig. 4 X-Y view of eight-rotor TUAV's trajectory

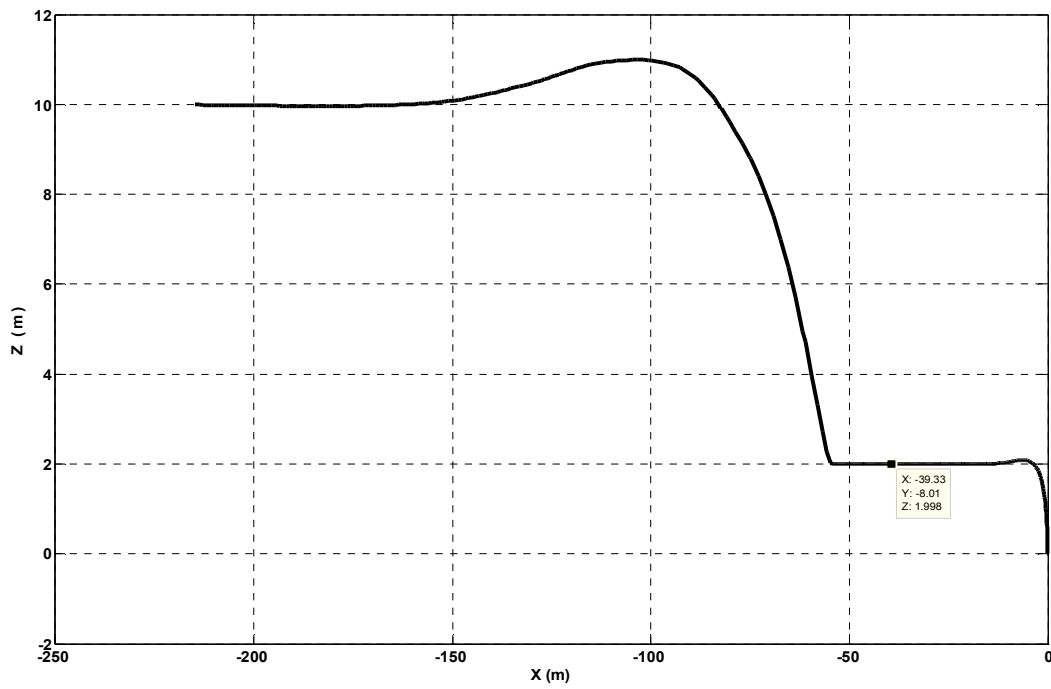

Fig. 5 X-Z view of eight-rotor UAV's trajectory

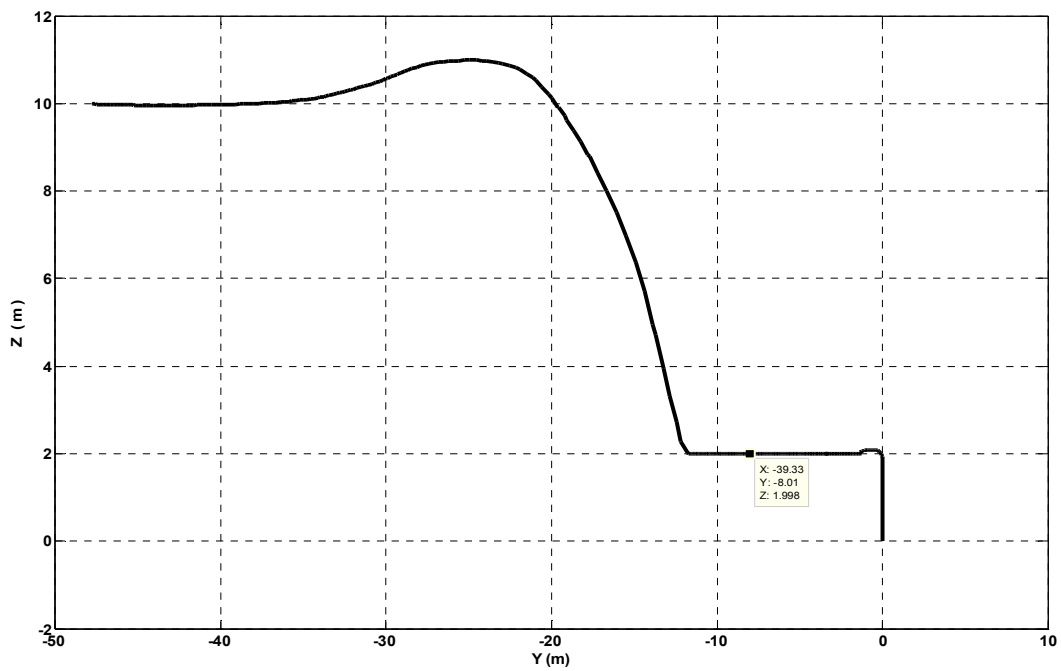

Fig. 6 Y-Z view of eight-rotor UAV's trajectory

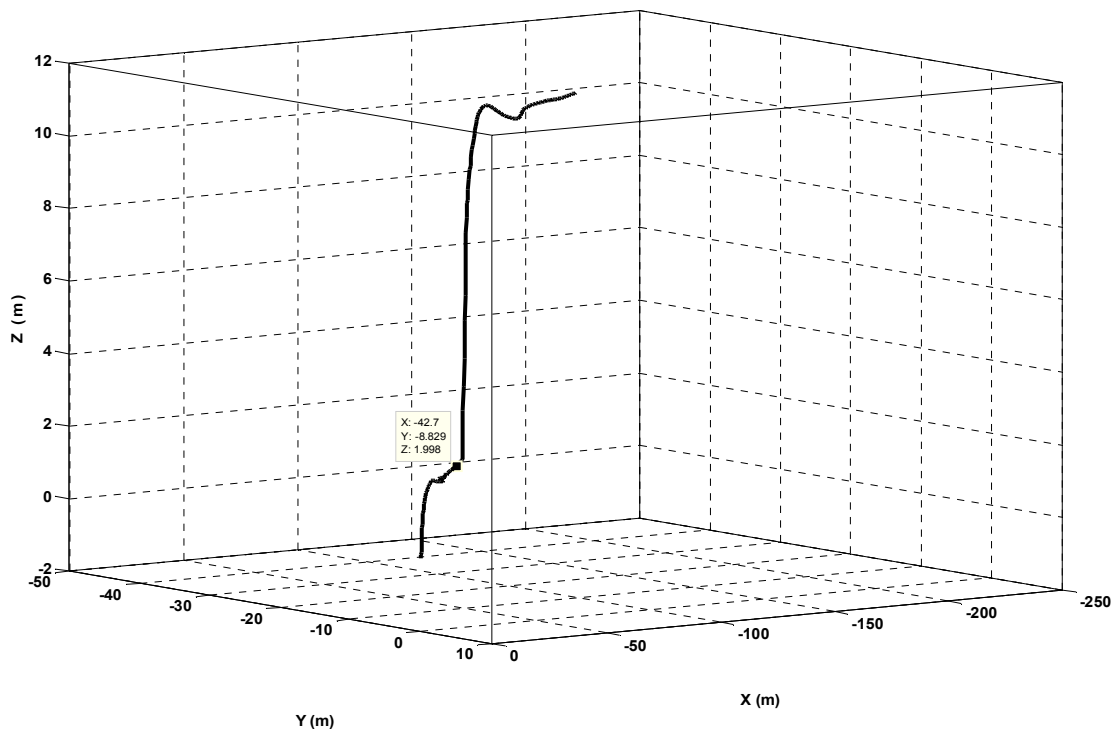

Fig. 7 3-D motion of eight-rotor TUAV

V. CONCLUSION

A new research technique is presented in this paper for enhanced SA in possible eight-rotor TUAV's missions.

The need for highly reliable and stable hovering for VTOL class TUAVs has increased morbidly for critical situations in real-time search-and-rescue operations for fast SA.

For fast, stable and smooth hovering maneuvers, we proposed a two stage flight strategy, which separates the flight process into initial and final phases. The effectiveness of the proposed flight strategy has been verified in field of flight simulation tests for chosen model of eight-rotor TUAV using software package Simulink.

From the applications viewpoint, we believe that this flight strategy furnish a powerful approach for enhancing SA in applications to unmanned multirotor helicopters and VTOL class autonomous vehicles.

Future work will involve further validation of the performance of the proposed research technique and exploring other relevant and interesting multirotor TUAV's missions.

REFERENCES

- [1] M. R. Endsley, "Toward a theory of situation awareness in dynamic systems," *Human Factors*, vol. 37, pp. 32-64, March 1995.
- [2] J. Gorman, N. Cooke, and J. Winner, "Measuring team situation awareness in decentralized command and control environments," *Ergonomics*, vol. 49, pp. 1312-1325, October 2006.
- [3] Interim Brigade Combat Team Newsletter. [Online]. Available: http://www.globalsecurity.org/military/library/report/call/call_01-18_toc.htm
- [4] S. D. Prior, S. T. Shen, A. S. White, S. Odedra, M. Karamanoglu, M. A. Erbil, and T. Foran, "Development of a novel platform for greater situational awareness in the urban military terrain," in *Proc. 8th International Conf. Engineering Psychology and Cognitive Ergonomics*, San Diego, USA, 2009, pp. 120-125.
- [5] I. Astrov and A. Pedai, "Control of hovering manoeuvres in unmanned helicopter for enhanced situational awareness," in *Proc. International Conf. Industrial Mechatronics and Automation*, Chengdu, China, 2009, pp. 143-146.
- [6] S. Salazar, H. Romero, J. Gomez, and R. Lozano, "Real-time stereo visual servoing control of an UAV having eight-rotors," in *Proc. 6th International Conf. Electrical Engineering, Computing Science and Automatic Control*, Toluca, Mexico, 2009, pp. 1-11.
- [7] K. Benzemrane, G. L. Santosuosso, and G. Damm, "Unmanned aerial vehicle speed estimation via nonlinear adaptive observers," in *Proc. 2007 American Control Conf.*, New York, USA, 2007, pp. 985-990.
- [8] H. Romero, S. Salazar, and R. Lozano, "Real-time stabilization of an eight-rotor UAV using optical flow," *IEEE Trans. Robotics*, vol. 25, pp. 809-817, August 2009.
- [9] D. Krutko, *Inverse Problems of Control System Dynamics: Nonlinear Models*. Moscow: Nauka, 1989.
- [10] L. S. Pontryagin, *Ordinary Differential Equations*. Moscow: Nauka, 1974.