

Software Engineering Interoperable Environment for University Process Workflow and Document Management

Bekim Fetaji, Majlinda Fetaji, Mirlinda Ebibi

Abstract—The objective of the research was focused on the design, development and evaluation of a sustainable web based network system to be used as an interoperable environment for University process workflow and document management. In this manner the most of the process workflows in Universities can be entirely realized electronically and promote integrated University. Definition of the most used University process workflows enabled creating electronic workflows and their execution on standard workflow execution engines. Definition or reengineering of workflows provided increased work efficiency and helped in having standardized process through different faculties. The concept and the process definition as well as the solution applied as Case study are evaluated and findings are reported.

Keywords—design process workflows, workflow and document management, Business Process, software engineering

I. INTRODUCTION

THE aim of this research was to help promoting integrated University. It enables smooth transition from current University organization from paper based into electronic and organized in integrated manner.

According to [1] workflow technology is becoming increasingly visible as a means for organizations to improve their productivity and competitive position, via automation and reengineering of business processes. Workflow systems offer organizations the ability to model, execute, report on, and dynamically control work processes that typically involve multiple people in collaboration. Individual users also have the opportunity to see how their tasks interact with other users' tasks and how these all fit together in a business process to achieve organizational goals [3].

The proposed implementation of a web based system for workflow and document management has twofold improvement in directions to improve usage of documents and improve organizational aspects.

Bekim Fetaji, is with the South East European University Contemporary Sciences and Technologies, Ilindenska bb, 1200 Tetovo, Macedonia, (phone: 00389-71-381-384; fax: 00389-44-356-001; e-mail: b.fetaji@seeu.edu.mk).

Majlinda Fetaji, is with the South East European University Contemporary Sciences and Technologies, Ilindenska bb, 1200 Tetovo, Macedonia, (phone: 00389-70-880-948; fax: 00389-44-356-001; e-mail: m.fetaji@seeu.edu.mk).

Mirlinda Ebibi, is with the South East European University Contemporary Sciences and Technologies, Ilindenska bb, 1200 Tetovo, Macedonia, (phone: 00389-71-349-703; fax: 00389-44-356-001; e-mail: m.ebibi@seeu.edu.mk).

The wider objective of the research is to design and establish a sustainable web based network system to be used as an interoperable environment for University workflow and document management. The sustainable web based network system enables equal opportunities and multilingual approach [2]. The appropriate ICT infrastructure enables transparent and easy access to all University workflow activities and documents.

Working Methodology and Processes involved the following software engineering steps: Analysis of needs and requirements; Conceptual design; detailed study and design of proposed solutions; Technical details analysis; Realization; Implementation; Dissemination and Sustainability.

In order to make the outputs of the research available to those who are not directly involved in the research and exploit massive usage of the system we specify plan for several dissemination actions. These will be achieved by printing information brochures, booklets, flyers, posters, web publishing and multimedia presentations. The target public of these dissemination actions is University decision making bodies, other University bodies or services that have an institutional impact, central University services and both teachers and students. The mission of building a bridge between science and industry, as well the possibility to get broader knowledge about this research topics and present the achieved results is also a part of dissemination activities.

Demonstrations are dissemination activity to be used for University decision making bodies after system implementation and integration. Afterwards, public presentations are given to administration of University and its constituent parts, Faculties and institutes. The system administrators were trained to use the system and to give support for initial use.

Dissemination activities are performed according to the adopted methodology and strategy. A system roll-out plan is defined and realized by ensuring relevant data for document and workflow are identified and populated within the system.

A plan of dissemination activities is also performed in order to promote integrated University and create conditions for implementation of this idea. These activities had impact on creation and adoption of appropriate legislation that will make changes to current University organization towards integrated University, by restructuring the ("business flow") workflow of activities and document sharing and exchange.

II. OBJECTIVES

This research focuses on the following objectives: restructuring of the management, organization and administration of universities; especially in the process of reorganization towards integrated University. The main goal is optimization of faculty-University relationship, meaning that with this research we will promote an integrated University of which faculties are constituent part and help realization of this idea. This will be achieved by using ICT tools and process reengineering of workflow activities in the University. The final benefit will be realization of the Bologna process recommendations.

This research aims at the reform of University administration with the support of University leadership and decision-making bodies. They require the active involvement of the administrative staff in charge of the implementation of reforms.

Target groups within university include all staff involved in the management and administration of a University, including staff of the University decision-making bodies and other University bodies or services that have an institutional impact; Central University services. Students will also participate in the research having access to all relevant documents and workflow mechanisms as representatives in the University decision-making.

The process of centralization from independent faculties towards integrated University is a long process and there will be a lot of problems arising in the implementation. This research is breakthrough and easy to make step towards rising awareness of reconstruction and integrated University. We are definitely sure that IT supported workflow and document management will give a smooth transition and realize ideas that usually are very hard to be implemented.

These reforms can not be undertaken directly by Ministry of Education, according to the integrity of the universities and the new adopted law for high education. Besides this, the active support of ministry and other regional or national authorities will be given towards realization and implementation of these ideas since beneficiary country has already signed agreement to realize Bologna declaration and represent the strong commitment towards bringing this country as member of EU.

III. ASSESSING ISSUES

Issues Identified are as follows:

- Undefined or poorly defined workflows
- Knowledge about administrative processes is implicit and knowledge transfer is very hard to automate
- Human Resources issues due to high staff engagement
- Cascading dependency creates more issues with each consequent year/session.

In order to improve the identified issues the research defines 9 most used workflow processes used at Faculties in South East European University [2] and transferred them to University within the Integrated University

Model. This enables easier transition of processes found at department and faculty levels and now being integrated in the Integrated University.

- Apply for position – this use case describes the process of election of the best candidate when there is an open position at the university.
- Realize a visit – this use case describes the steps conducted in the realization of a visit.
- Publish a teaching material – this use case describes the process conducted to get a teaching material approved.
- Project proposal – every project as a working idea is to be approved by the university bodies before it is submitted.
- Thesis submission – the process of getting a thesis approved for defense is described in this use case.
- Realization of teaching – this use case describes the reporting during the teaching process.
- Service request – all the requests at the university are handled in this use case.
- Resource reservation – this use case describes the process of reserving resources (technical and material) which are shared resources at the university.
- Annual reporting – the process of per annual reporting is described in this use case.

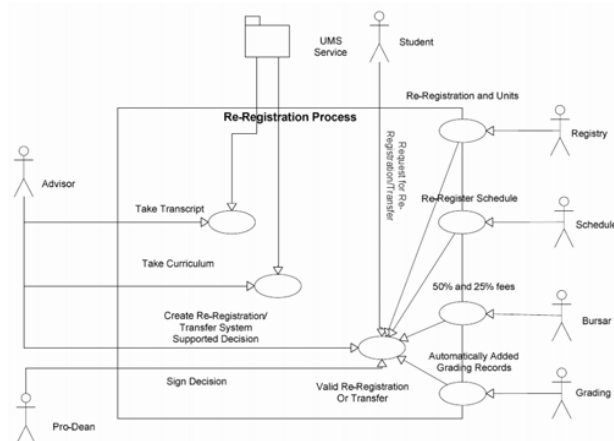

Fig. 1 Workflow Re-registration procedure

IV. SYSTEM ARCHITECTURE

Logically, the application is divided in number of levels. Each level provides certain degree of abstraction and modularity for the range of its work.

Database Provider – it abstracts the work with the data base and provides a simple programming interface. It should be designed modularly for the purpose of providing easy access to different types of data bases like SQL, Oracle, MySQL etc.

Base Object Model - defines all of the objects/model/structures that will be used in the application. Also, the inner structure of the portal is defined.

Business Objects/ Logic – this is where all of the business objects and logic in the application are defined.

Service – encapsulates some business process running in

the application. Example: user login process, check for user rights etc.

UI Process Components – it represents precisely defined process by which the user input is accepted and processing of it.

UI – user interface for the interaction with the application.

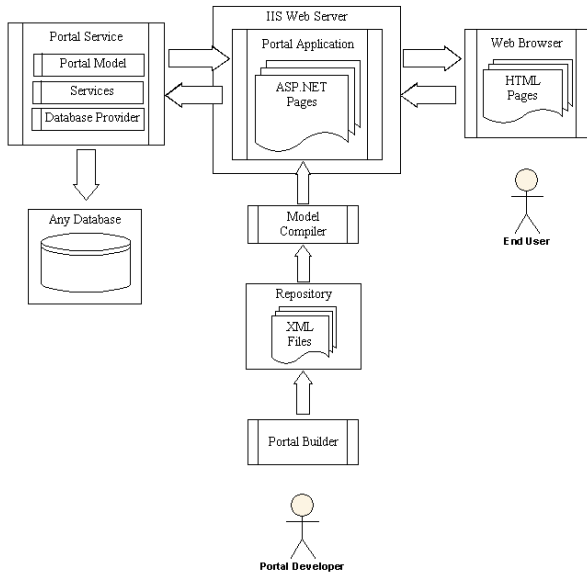

Fig. 2 System Overall

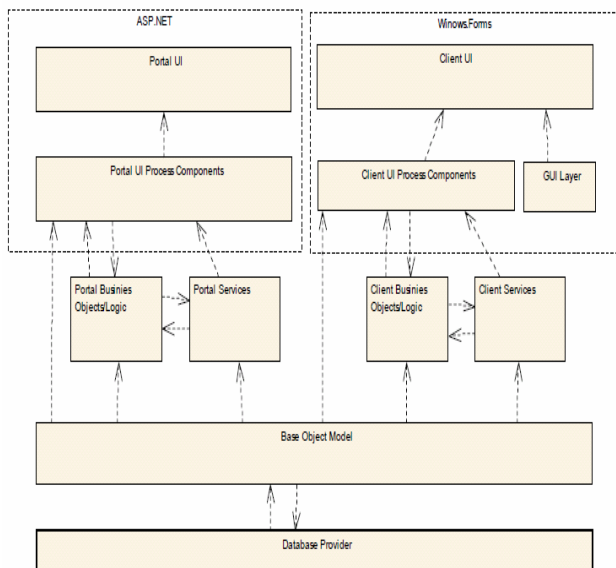

Fig. 3 Application Layers

Portal Service – background service for processing the requests of the services and enables access to the data base. Service has the following structure:

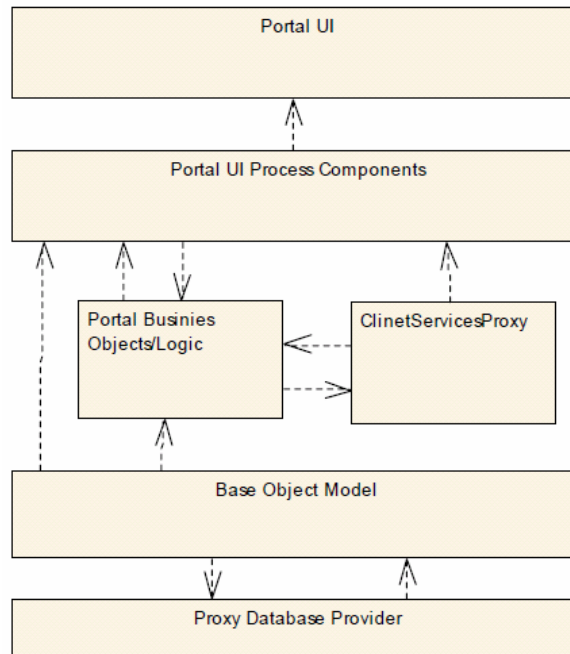

Fig. 4 Portal Service Layers

PortalServicesProxy – it should provide for portal services to be available through .Net Remote.

Portal Application – it represents the actual web application which is generated by the client application.

- ClientServicesProxy – enables logic for communication between clients and services in Portal Service.
- Proxy Database Provider – it provides mechanism for the client to access the Database Provider level of the Portal Service.
- Portal Builder – client application (IDE) for developing web applications.

V. SERVICE LAYER

System provides services for support for the other parts of the application. The service is a sum of help functions, properties, events which belong to one logical unit. Services are created once and are always available for all the parts of the application. All services should implement the following interface:

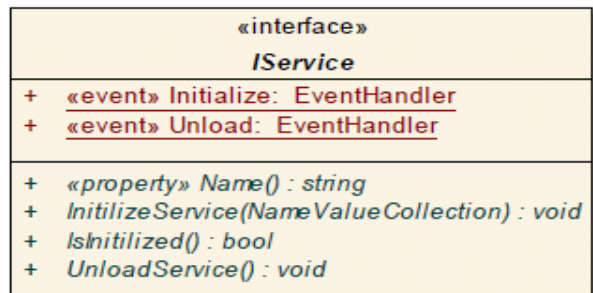

Fig. 5 Service

- Name – unique name of the service for accessing it.
- InitializeService – initialization of the service.
- IsInitialized – returns status if the service is initialized.
- UnloadService – releases all the resources that service uses.
- Initialize – event that happens on the initialization of the service.
- Unload – event that happens when the services is released.

The service Manager holds all the services available to the application and is the only place for accessing some service. Everybody requesting access to some service must do that through IServiceManager.

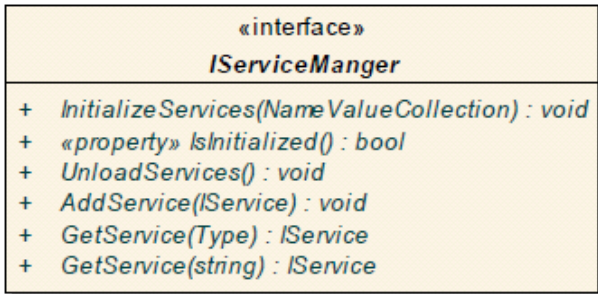

Fig. 6 Service Manager

- InitializeServices – initializes all of the added services.
- IsInitialize – returns status if the manager is initialized.
- AddService – adds new service that should be available.
- UnloadServices – releases all services.
- GetService – return a certain type of service. The request is through the name of the service or its type.

To be sure that only one instance of this object will be running, it is implemented as singleton object.

IRequestPermissions interface should be implemented by all of the models that needs certain rights for Access. Permissions – list of rights that the user should have in order to gain access to this model.

Figure below presents the objects and the messages they exchange in the process of transforming the models from XML presentation to real objects:

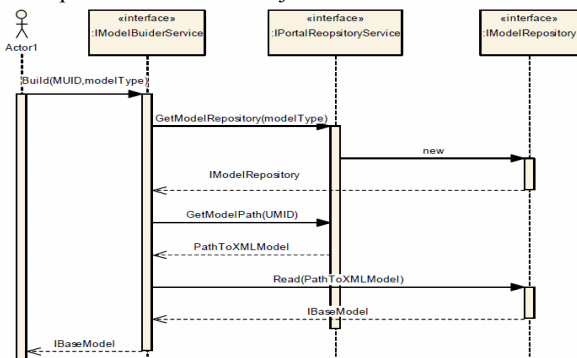

Fig. 7 Communication Diagram

VI. MULTILANGUAGE SUPPORT FOR WORKFLOWS

It should be possible during the development of the portal to define languages of the portal and to be possible to add words in the defined languages.

Multi language support is provided by two services:

ILanguageService: Can load a language and provide access to specific words.

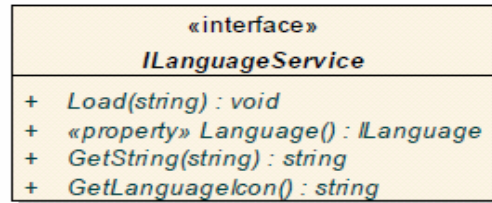

Fig. 8 Language Service

- **Load** – loads the language. Name of the language is given as parameter.
- **Language** – current loaded language.
- **GetString** – returns the string that pairs the StringID, which is given as parameter.
- **GetLanguageIcon** – returns path to the icon of the current language.

ILanguageManager: Through this manager it will be possible to add new languages into the system and adding new words in the language files.

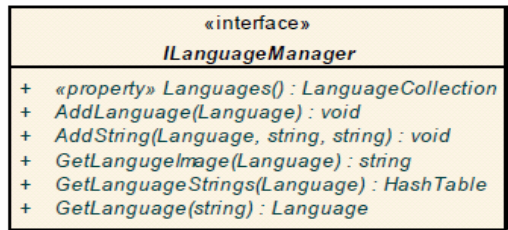

Fig. 9 Language Manager

- **Languages** – collection of defined languages.
- **AddLanguage** – adds new language in the collection and into the XML file.
- **AddString** – adds new string in the specified language, in the same time writing it in the language XML file.
- **GetLanguageImage**- returns path to the icon of the language.
- **GetLanguageStrings**- returns all string stored for the specified language.
- **GetLanguage** – returns ILanguage object for the language with the specified name.

VII. IMPLEMENTATION

The portal server is installed as an IIS 6.0 ASP.NET server application:

The installation is like ordinary ASP.NET applications which makes it easy to understand

The server application is built on custom ASP.NET modules and maintenance without the Portal Builder application is hard to realise:

The only way to fix minor or major issues with the server

application is to rebuild it completely with the Portal Builder

There is no way to make appropriate or custom changes in the Portal Builder resulting application (such as make design changes after it has been built)

General functionalities and business process is illustrated through the UML diagrams. As example the sequence diagram is presented below for the workflow process “Apply for Position”.

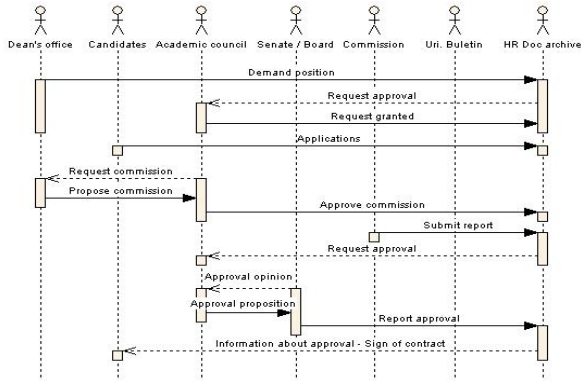

Fig. 10 “Apply for Position” workflow process

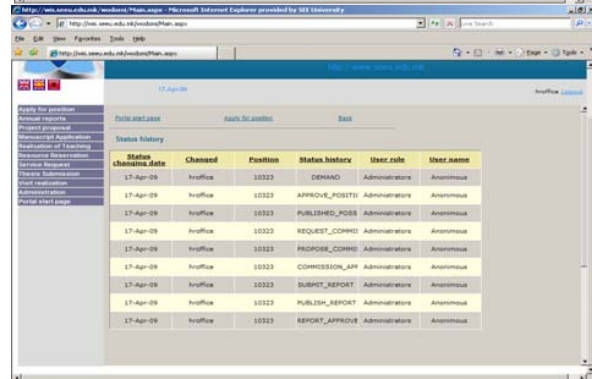
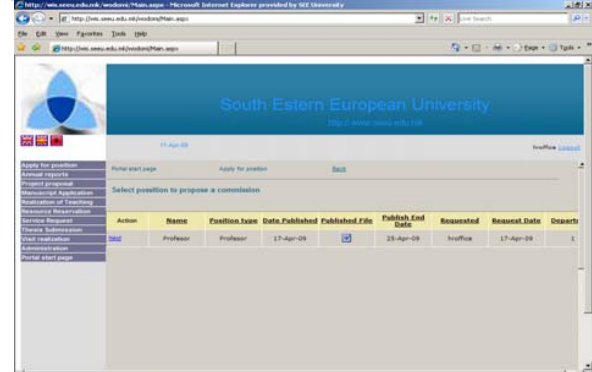
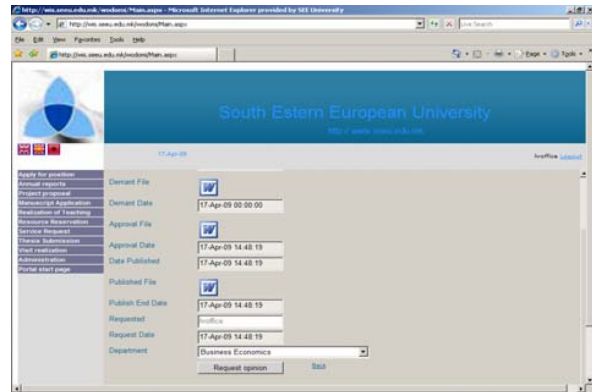

Fig. 13 Application Interface workflow steps

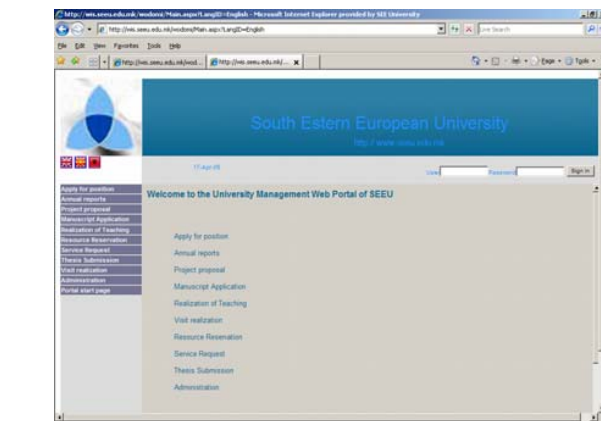

Fig. 11 Software solution for University workflow and document management

VIII. RESULTS

The research study reviewed the following findings: *Usability issues* according to the personal training sessions and demonstrations with selected SEEU users:

The users of the portal application have noted:

- They find it somewhat hard to use and navigate over the options
- Better indication when the document is uploaded.
- Columns of the forms are very tight. The text could not be read.
- When creating a new candidate, the password field is not masked with standard characters (asterix)

Evaluation Results

- The referent data (Job positions, etc.) are not displayed as lists.

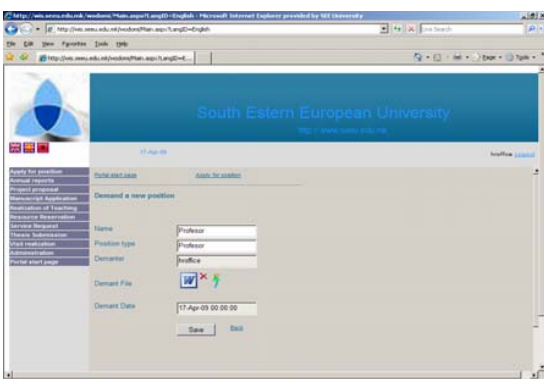

Fig. 12 interface for “Apply for Position” workflow process

- Constraint problem – two different candidates with same username
- Problem on Fully integration with Active Directory.
- Access Control List problems (the candidate sees all menu items) and, also the candidate has access to all uploaded documents.
- Vulnerable to exploits and scripts
- Delete problems - cannot delete candidate or when candidate name is shown in the candidate overview list.
- Problem organizing units – Faculties, departments.
- Time or other alerts (triggering)
- Data management system (archive)
- Forms are not user friendly and interactive – A large forms are shown in horizontal directions which needs a long horizontal scrolling to see all form.

Testing Results

High return time and low error averages

- Faster workflow execution
- Better and faster results
- Less manpower
- Faster delivery time

Title	#	Minutes	8h Fulltime Days
# records avg.	50,000	0.2	20.83333
# errors avg.	5,000	0.5	5.208333
# sheets avg.	1,000	0.5	1.041667
Total			27.08333

Title	#	Minutes	8h Fulltime Days
# errors avg.	3,000	0.5	3.1250001
# sheets avg.	1,000	0.5	1.0416667
Total			4.1666668

Fig. 14 Testing Results

IX. CONCLUSION

Analyzed the following indicators: methods and techniques used in methodology; implementation issues in the model for the web based system; verification, validation, testing procedures; implementation plan, training plan; activities specified in dissemination strategy and sustainability procedures.

Besides these quality indicators used were quantity indicators for system usage by measuring the number of installations, number of documents shared and exchanged for a given period, number of workflow activities used for a given period, etc.

The outcomes from this research are:

1. Methodology to design ICT architecture for administrative workflow and document exchange - (required for second output and will lead to "reorganization" of administrative issues of constituent organizations towards integrated University).
2. Model of web based workflow and document management - (will give technical details, tender procedure for equipment purchase and implementation procedures)
3. Implementation of a sustainable web based system - (including verification and validation, testing, system implementation, demonstration and training)
- 4.

The outcomes from this research at beneficiary universities will have durable character. There are several reasons for sustainability:

- University and its constituent parts will continue to use the system since it will enable a lot of improvements like: paperless work, easier monitoring of activities, document share and exchange;
- Both the students and teachers will like to use new web based system due to its easy public access;

Two main sustainability procedures were undertaken within this research. The first activity concerned maintenance procedures and system improvement upgrade policy. Possible obstacles, failures and possibilities to improve workflow and document management will be shown by life performance of the system. Technical sustainability of the web system will be realized by giving solutions to these problems. This will lead towards functional sustainability and overall organizational sustainability.

The second sustainability procedure addresses "business flow" organizational changes and realizes sustainability at policy level. Beneficiary university decision making bodies will make all efforts to enable adoption of new legislation that will lead towards realization of integrated University and therefore realize institutional sustainability. By adopting legislation to use shared documents and easy access to workflow mechanisms, University decision making bodies will ensure also financial sustainability of the system, appointing budget for system administrators and system maintenance.

REFERENCES

- [1] Diimitrios Georgakopoulos, Mark Hornick and Amit Sheth² (2005): An overview of workflow management: From process modeling to workflow automation infrastructure, Journal Distributed and Parallel Databases, Publisher Springer Netherlands ISSN0926-8782 (Print) 1573-7578 (Online) Issue: Volume 3, Number 2 / April, 1995 DOI10.1007/BF01277643 Pages119-153
- [2] Fetaji Bekim., Fetaji, Majlinda.,(2007) "E-learning Indicators Approach to Developing E-learning Software Solutions" – EUROCON 2007, IEEE conference, (pp 2687-2694), Warsava, Poland, 9-12 Sept. 2007.
- [3] Baeza-Yatez R., Ribeiro-Neto B., (2001) Modern Information Retrieval, Chapter 10, ACM Press: Addison-Wesley.