

Using the Shunt Active Power Filter for Compensation of the Distorted and Unbalanced Power System Voltage

I. Habi, M. Bouguerra, D. Ouahdi, and H. Meglouli

Abstract—In this paper, we apply the PQ theory with shunt active power filter in an unbalanced and distorted power system voltage to compensate the perturbations generated by non linear load. The power factor is also improved in the current source. The PLL system is used to extract the fundamental component of the even sequence under conditions mentioned of the power system voltage.

Keywords—Converter, power filter, harmonics, non-linear load, pq theory, PLL, unbalanced voltages, distorted voltages.

I. INTRODUCTION

IN three-phase ac power system, the voltage unbalance and distortion can occur due to several reasons, as unbalanced load, open delta transformer connection, disconnected three phase capacitor bank and the proliferation of nonlinear and large single-phase loads [1]. The voltage unbalance and distortion may cause undesirable effects on the power system operation, particularly when sensitive loads are present. Moreover, the source voltage unbalance can worsen the system power quality when supplied to power electronic converter, Ac machines and drive systems. For examples, nonlinear loads such as static converters supplied by unbalanced voltages produce uncharacteristic low frequency harmonics, which increase the ratings of filters and switches. A machines subjected to unbalanced voltage source may generate large negative-sequence current components due to low negative-sequence impedance, thus increasing machine losses and reducing the net torque [2]. Other forms of poor power quality are voltage sags, swells and partial or total collapse of one or more phases. These problems are normally caused by faults on adjacent feeders such as phase to ground or phase to phase faults. Therefore, it is necessary to improve power quality of the system to meet the standard given by IEEE II59"

II. SHUNT ACTIVE POWER FILTER

Active power filter (APF) is a power electronics device based on the use of power electronics switching by the inverter (Fig. 1). The APF inject power in to the PCC in a small amount by ratio of the power delivered from source to load. This small amount of power is adjusted by changing the

amplitude of the fundamental component of the compensating current that can dynamically suppress harmonics, compensate reactive power and unbalance in the load current [3]. The result of this is that the utility currents prior to the PCC become sinusoidal and in phase with the respective source voltage, i.e., unity PF, and with balanced magnitudes.

In active power filter applications, the VSI output voltage must be able to generate an output current that follows the respective reference current.

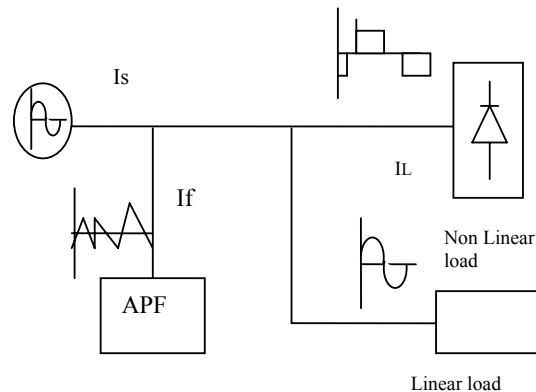

Fig. 1 Basic principle of active power filter (APF)

The block diagram of a shunt active power filter control scheme is shown in (Fig. 2) and consists of sensing the load currents and the PCC voltages, reference current generator, DC voltage control, injected current control and the inverter.

The compensation effectiveness of an active power filter depends on its ability to flow with a minimum error and time delay the reference signal calculated to compensate the distorted load, current finally, the DC voltage control unit must keep the total DC voltage constant and equals to a given reference value. The DC voltage control is achieved by adjusting the small amount of real power absorbed by the inverter from the PCC. This small amount of real power is adjusted by changing the amplitude of the fundamental component of the reference current.

Authors are with Research Laboratory on Industrial Factories Electrifications, University of Boumerdes, Algeria (e-mail: Habi_idir@yahoo.fr).

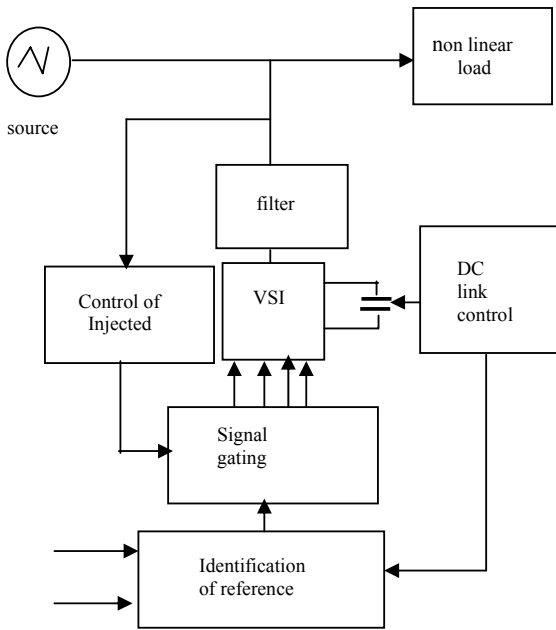

Fig. 2 Control schemes of shunt active power filter

The pq theory use the Clark transformation to transform the PCC voltages, e_{sa} , e_{sb} and e_{sc} and the load i_{La} , i_{Lb} and i_{Lc} into the orthogonal coordinates α and β as follow:

$$\begin{bmatrix} e_{\alpha} \\ e_{\beta} \end{bmatrix} = \frac{\sqrt{2}}{\sqrt{3}} \begin{bmatrix} 1 & 1/2 & 1/2 \\ 0 & \sqrt{3}/2 & \sqrt{3}/2 \end{bmatrix} \begin{bmatrix} e_{sa} \\ e_{sb} \\ e_{sc} \end{bmatrix} \quad (1)$$

$$\begin{bmatrix} i_{L\alpha} \\ i_{L\beta} \end{bmatrix} = \frac{\sqrt{2}}{\sqrt{3}} \begin{bmatrix} 1 & 1/2 & 1/2 \\ 0 & \sqrt{3}/2 & \sqrt{3}/2 \end{bmatrix} \begin{bmatrix} i_{La} \\ i_{Lb} \\ i_{Lc} \end{bmatrix} \quad (2)$$

The theory pq [4-5] gives the instantaneous real power p_L and the instantaneous imaginary power q_L delivered by the source to the non linear load, defined by:

$$\begin{bmatrix} p_L \\ q_L \end{bmatrix} = \begin{bmatrix} e_{\alpha} & e_{\beta} \\ -e_{\beta} & e_{\alpha} \end{bmatrix} \begin{bmatrix} i_{L\alpha} \\ i_{L\beta} \end{bmatrix} \quad (3)$$

q_L and p_L contain two terms as a function of the frequency:

$$p_L = \overline{p_L} + \underline{p_L} \quad (4)$$

$$q_L = \overline{q_L} + \underline{q_L} \quad (5)$$

Where [5-4-6] :

\overline{p} : value of the instantaneous real power..

\underline{p} : oscillate power of the instantaneous real power, it is the energy per time unity, being exchanged between the power supply and the load.

\overline{q} : mean value of the reactive imaginary power. It is a dc component, and it doesn't contribute in the amount of energy transferred from the source to the load.

\underline{q} : oscillate power of the instantaneous imaginary power, it corresponds to the power exchanged between the phases of the load [7].. The reference currents used for the control of the VSI must be followed by the injected current in the PCC, witch are given by:

$$\begin{bmatrix} i_{ref\alpha} \\ i_{ref\beta} \\ i_{refc} \end{bmatrix} = \frac{\sqrt{2}}{\sqrt{3}} \begin{bmatrix} 1 & 0 \\ 1/2 & \sqrt{3}/2 \\ 1/2 & \sqrt{3}/2 \end{bmatrix} \begin{bmatrix} e_{s\alpha} & e_{s\beta} \\ -e_{s\beta} & e_{s\alpha} \end{bmatrix} \begin{bmatrix} p^* \\ q^* \end{bmatrix} \quad (6)$$

P^* : Instantaneous real power reference;

q^* : Instantaneous imaginary power reference.

III. COMPENSATION OF UNBALANCED HARMONICS AND REACTIVE POWER UNDER SINUSOIDAL BALANCED POWER SYSTEM VOLTAGES

In this case we have to compensate the oscillating parts of the powers absorbed by the load, the dc component of the reactive power and the zero current component, the reference currents are given by:

$$\begin{bmatrix} i_{rf\alpha} \\ i_{rf\beta} \\ i_{rfc} \end{bmatrix} = \frac{\sqrt{2}}{\sqrt{3}} \begin{bmatrix} 1 & 0 & 1/2 \\ 1/2 & \sqrt{3}/2 & 1/2 \\ 1/2 & \sqrt{3}/2 & 1/2 \end{bmatrix} \begin{bmatrix} e_{s\alpha} & e_{s\beta} & 0 \\ -e_{s\beta} & e_{s\alpha} & 0 \\ 0 & 0 & 1 \end{bmatrix} \begin{bmatrix} p^* \\ q^* \\ i_{rf0} \end{bmatrix} \quad (7)$$

$$\text{Where: } p^* = \underline{p} \quad (8)$$

$$q^* = \overline{q} + \underline{q} \quad (9)$$

Since the zero-sequence current must be compensated, the reference current in the $\alpha, \beta, 0$ coordinate is i_{L0} itself.

$$i_{rf0} = i_{L0} = 1/\sqrt{3}(i_{La} + i_{Lb} + i_{Lc}) \quad (10)$$

For unbalanced and distorted power system voltage we can write:

$$\begin{cases} V_{sa}(t) = \sum_{i=1}^{\infty} \sqrt{2} V_{ami} * \sin(\theta + \phi_{kai}) \\ V_{sb}(t) = \sum_{i=1}^{\infty} \sqrt{2} V_{bmi} * \sin(\theta + \phi_{kbi} - 2\pi/3) \\ V_{sc}(t) = \sum_{i=1}^{\infty} \sqrt{2} V_{cmi} * \sin(\theta + \phi_{kci} + 2\pi/3) \end{cases} \quad (11)$$

$$V_{sd} = V_{sdf} + \underline{V}_{sd} \quad (18)$$

$$V_{sq} = V_{sqf} + \underline{V}_{sq} \quad (19)$$

$$V_{sdf} = V_{sdfp} + V_{sdfn} = \sqrt{3} \left\{ -V_p \sin(\bar{\theta} - \theta) + V_i \sin(\bar{\theta} + \theta) \right\} \quad (20)$$

$$V_{sqf} = V_{sqfp} + V_{sqfn} = \sqrt{3} \left\{ -V_p \sin(\bar{\theta} - \theta) + V_i \sin(\bar{\theta} + \theta) \right\} \quad (21)$$

V_{sdf} : Fundamental of d axis ;

\underline{V}_{sd} : harmonic component of d axis;

V_{sqf} : Fundamental component of the q axis ;

\underline{V}_{sq} : harmonic component of the q axis ;

V_{sdfp} : direct fundamental component due to positive sequence;

V_{sdfn} : direct fundamental component due to negative sequence;

V_{sqfp} : direct fundamental component due to positive sequence;

V_{sqfn} : direct fundamental component due to negative sequence;

Generally we can express the currents generated by an unbalanced non linear load with the positive, negative and zero sequences as follow:

$$V_{san}(t) = \sqrt{2} V_{0n} * \sin(\omega t + \phi_{0n}) + \sqrt{2} V_{pn} * \sin(\omega t + \phi_{pn}) + \sqrt{2} V_{in} * \sin(\omega t + \phi_{in} - 2\pi/3) \quad (12)$$

$$V_{sb}(t) = \sqrt{2} V_{0n} * \sin(\omega t + \phi_{0n}) + \sqrt{2} V_{pn} * \sin(\omega t + \phi_{pn} - 2\pi/3) + \sqrt{2} V_{in} * \sin(\omega t + \phi_{in} + 2\pi/3) \quad (13)$$

$$V_{sc}(t) = \sqrt{2} V_{0n} * \sin(\omega t + \phi_{0n}) + \sqrt{2} V_{pn} * \sin(\omega t + \phi_{pn} + 2\pi/3) + \sqrt{2} V_{in} * \sin(\omega t + \phi_{in} - 2\pi/3) \quad (14)$$

To extract the fundamental component of the positive sequence we use a PLL (phase Locked Loop). Firstly we apply the Park transformation to the power system voltages V_{sa} , V_{sb} and V_{sc} with estimated angle $\bar{\theta}$. The PLL gives the signal desired only if $\bar{\theta} \neq \theta$, where θ is the phase of the power system voltages (Fig.3). Park transformation matrix is:

$$\begin{bmatrix} V_{sd} \\ V_{sq} \\ V_{s0} \end{bmatrix} = \sqrt{\frac{2}{3}} \begin{bmatrix} \cos(\bar{\theta}) & \cos(\bar{\theta} - 2\pi/3) & \cos(\bar{\theta} + 2\pi/3) \\ -\sin(\bar{\theta}) & -\sin(\bar{\theta} - 2\pi/3) & -\sin(\bar{\theta} + 2\pi/3) \\ 1/\sqrt{2} & 1/\sqrt{2} & 1/\sqrt{2} \end{bmatrix} * \begin{bmatrix} V_{sa} \\ V_{sb} \\ V_{sc} \end{bmatrix} \quad (15)$$

Finally we find

$$V_{sd} = \sqrt{3} \left[\sum_{i=1}^{\infty} -V_{pn} \sin(\bar{\theta} - \theta_i) + \sum_{i=1}^{\infty} V_{in} \sin(\bar{\theta} + \theta_i) \right] \quad (16)$$

$$V_{sq} = \sqrt{3} \left[\sum_{i=1}^{\infty} V_{pn} \cos(\bar{\theta} - \theta_i) + \sum_{i=1}^{\infty} V_{in} \cos(\bar{\theta} + \theta_i) \right] \quad (17)$$

For balanced sinusoidal power system voltages we obtain:

$$V_{sd} = 0 \quad (22)$$

$$V_{sq} = -\sqrt{3} V_p \quad (23)$$

In the PLL circuit we use a PI controller to keep the direct component equal to zero (Fig. 3)

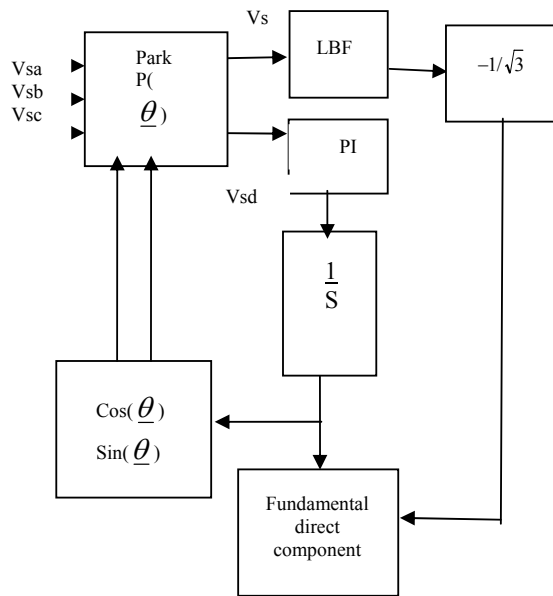

Fig. 3 Control scheme of shunt active power filter

IV. SIMULATION RESULTS

The use of the PLL has been verified by simulation. The results are divided into to cases according to the conditions

imposed by the power supply voltages.

A. Case 1: unbalanced power supply voltages.

In this case we have taken the following parameters:

$$\begin{cases} V_{sa} = k_1 * V \cos(\omega t + \gamma_1) \\ V_{sb} = k_2 * V \cos(\omega t - 2\pi/3 + \gamma_2) \\ V_{sc} = k_3 * V \cos(\omega t + 2\pi/3 + \gamma_3) \end{cases} \quad (24)$$

$$V = 220\sqrt{2}v \quad (25)$$

$$\begin{cases} \gamma_1 = \pi/3 & k_1 = 0.8 \\ \gamma_2 = \pi/4 & k_2 = 0.6 \\ \gamma_3 = \pi/6 & k_3 = 1.0 \end{cases}$$

The results are presented in Fig. 4, Fig. 5, Fig. 6 and Fig. 7, the PLL is being used at t=0. 25s .we can see clearly that the current supply becomes sinusoidal just at the instant of application' PLL. The charging of Dc-link voltage has less fluctuation.

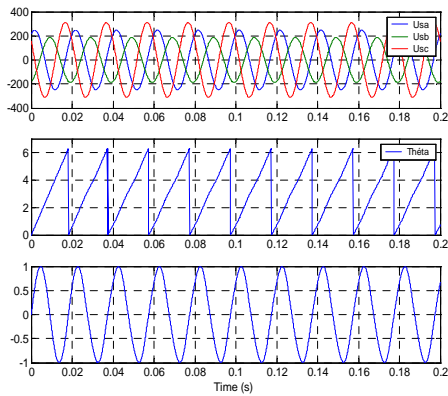

Fig. 4 Control sheme of shunt active power filter

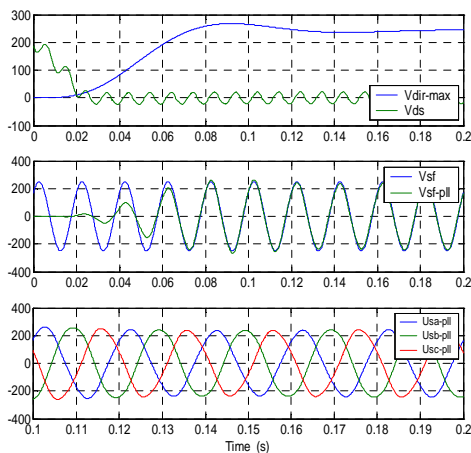

Fig. 5 Fundamental voltage detection in (V)

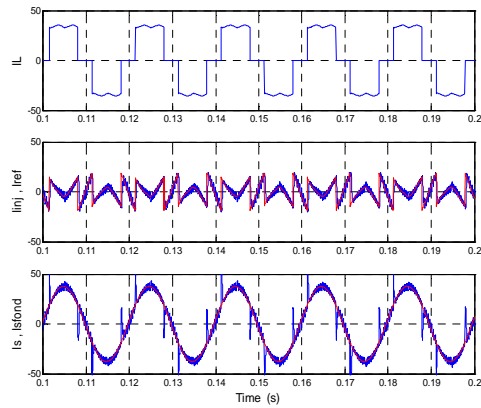

Fig. 6 Harmonic current compensation (A)

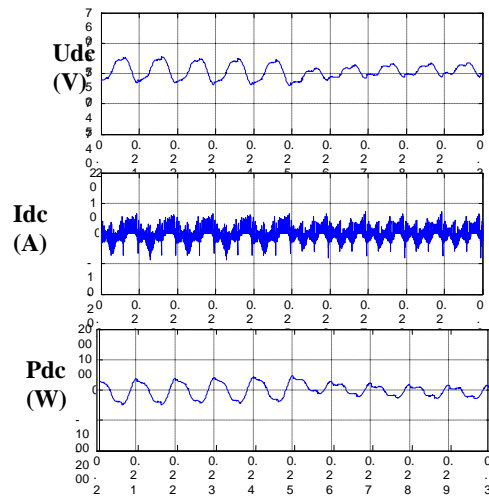

Fig. 7 Comportement du DC_Link

B. Case 2: unbalanced distorted power supply voltages.

In this case we have taken the following Voltages for the power supply:

$$\begin{aligned} V_{sa} &= 0.8V \{ \sin(\theta + \pi/3) + \sin 5(\theta + \pi/3) + \sin 7(\theta + \pi/3) \} \\ V_{sb} &= 0.6V \{ \sin(\theta - 2\pi/3 + \pi/4) + \sin 5(\theta - 2\pi/3 + \pi/4) + \sin 7(\theta - 2\pi/3 + \pi/4) \} \\ V_{sc} &= V \{ \sin(\theta + 2\pi/3 + \pi/6) + \sin 5(\theta + 2\pi/3 + \pi/6) + \sin 7(\theta + 2\pi/3 + \pi/6) \} \end{aligned} \quad (26)$$

The results are presented in Fig. 8, Fig. 9, Fig. 10 and Fig. 11, the PLL is being used at t=0. 25s, we can see clearly that the current supply becomes sinusoidal just at the instant of application of the PLL. The peaks are due to the fast variation of the current in the nonlinear load, this causes a large fluctuation in di/ dt .The charging of Dc-link voltage has less fluctuation. The value of V is becoming more oscillating but with average value equal to zero.

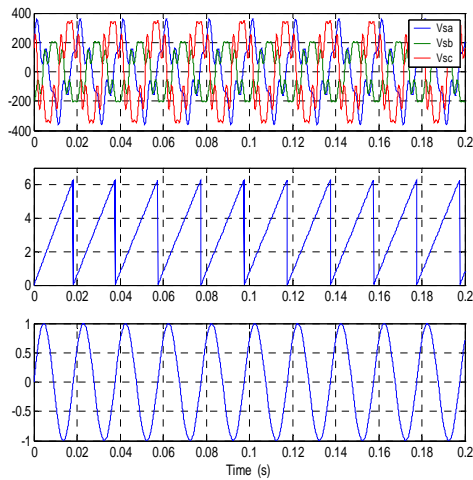

Fig. 8 Control scheme of shunt active power filter

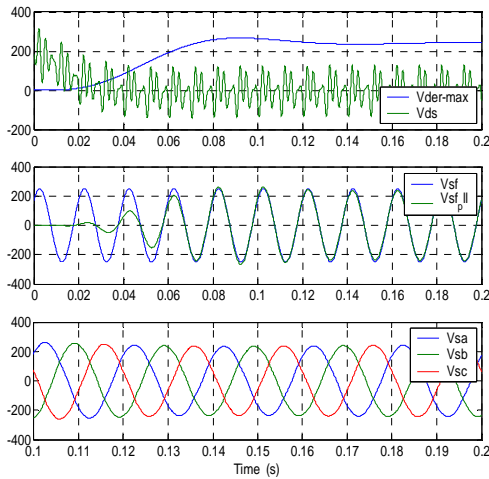

Fig. 9 Control scheme of shunt active power filter

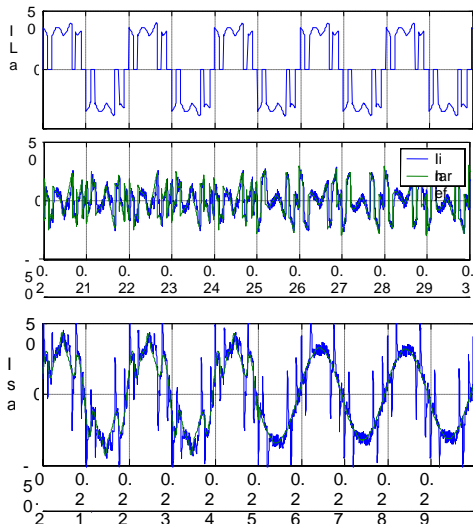

Fig. 10 Control scheme of shunt active power filter

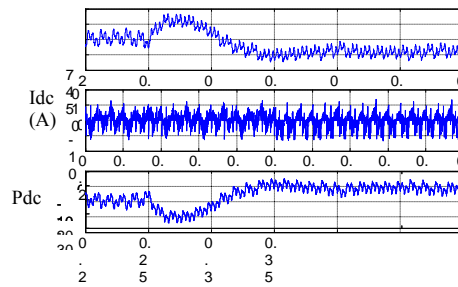

Fig. 11 Control scheme of shunt active power filter

V. CONCLUSION

In this paper, we have demonstrated that the use of a PLL improve the behaviours of the pq control algorithm. We have found that we can solve the drawback of the pq theory even if the supply voltages is unbalance or distorted by the use of a PLL "Phase Locked Loop" . The PLL used gives a great improvement of power quality without any shift phase between the input and the output signals. The fluctuation of the D-link voltage decreases in this case. The simulation results show a very good performance of the proposed configuration of the pq algorithm with a PLL.

REFERENCES

- [1] Lee C Y, Chen B K, Lee W J, Hsu YF." Effects of Various unbalanced voltages on the operation performance of an induction motor under the same voltage unbalance factor condition". Annual Meeting, IEEE 1997: 51-59.
- [2] Souto CN, De Oliveira JC, Ribeiro Pf, Neto LM." Power quality impact on performance and associated costs of three-phase induction motors", Proceeding Harmonics and Quality of power 1998, Vol. 2, 791797.
- [3] Zhou L, Jiang J, Zhou X, "Three phase four wire active power filter with unified constant frequency integration control," Power systems and communications Infrastructures for the future, Beijing, Sep 2002.
- [4] H. Akagi, Y. Kanazawa, A. Nabea, "Generalized theory of the instantaneous reactive power in three-phase circuits," IPEC'83-Int. Power Electronics Conf, Tokyo, Japan, 1983, pp. 1375-1386.
- [5] H. Akagi, Y. Kanazawa, A. Nabea., "Instantaneous reactive power compensators comprising switching devices without energy storage components," IEEE Trans Ind. Appl, Vol. 14-20, p.625, 1984.
- [6] E.H. Watanabe, M Aredes, II, Akagi, "The pq theory for active control: some problems and solutions," XIV, Congresso Brasileiro de Automatica., Natal-RN, 2 a 5 de setembro de 2002.
- [7] Mc Ared'es, H. Watanabe, "New control algorithms for series and shunt three-phase four wire active power filters," IEEE, Trans on Power Delivery, vol. 10, W. 3, July 1995.