

A New Method for Contour Approximation Using Basic Ramer Idea

Ali Abdrhman Ukasha

Abstract—This paper presented two new efficient algorithms for contour approximation. The proposed algorithm is compared with Ramer (good quality), Triangle (faster) and Trapezoid (fastest) in this work; which are briefly described. Cartesian co-ordinates of an input contour are processed in such a manner that finally contours is presented by a set of selected vertices of the edge of the contour. In the paper the main idea of the analyzed procedures for contour compression is performed. For comparison, the mean square error and signal-to-noise ratio criterions are used. Computational time of analyzed methods is estimated depending on a number of numerical operations. Experimental results are obtained both in terms of image quality, compression ratios, and speed. The main advantages of the analyzed algorithm is small numbers of the arithmetic operations compared to the existing algorithms.

Keywords—Polygonal approximation, Ramer, Triangle and Trapezoid methods.

I. INTRODUCTION

IN this paper we used method known as single step parallel contour extraction method “SSPCE” [1]. Many polygonal approximation techniques have been proposed in the literature and it can be classified into three categories. The first one is referred to as sequential method such as [2]. The second one is referred to as split-and-merge approaches such as in [3], [4], [5], [10], and [11]; and the last category is referred to as dominant point-detection approaches such as in [6]. The common contour representation is Cartesian [7], and is used in this work. Other representations such as Polar or Freeman’s (also generalized) chain coding are usually desirable in many applications [8]. The proposed algorithms is presented and compared with Ramer [3], Triangle [4] & [10], and Trapezoid [9] & [12] methods. The analyzed algorithms is introduced to obtain less number of arithmetic operations with good quality either. The two analyzed algorithms belong to a family of polygonal methods of approximation.

II. RAMER ALGORITHM

Contour is represented as a polygon when it fits the edge points with a sequence of line segments. There are several algorithms available for determining the number and location of the vertices and also to compute the polygonal approximation of a contour. The well known is Ramer method which is based on the polygonal approximation scheme [3]. The simplest approach for the polygonal approximation is a recursive process (Splitting methods).

The author is with the Department of Electronics, Sebha University, Faculty of Engineering, P. O. Box 68, Brack, Alshatti, Libya.
e-mail:elokshy@yahoo.com

Splitting methods work by first drawing a line from one point on the boundary to another. Then, we compute the perpendicular distance from each point along the segment to the line. If this exceeds some threshold, we break the line at the point of greatest error. The idea of this first curve approximation is illustrated in Fig. 1.

We then repeat the process recursively for each of the two new lines until we don’t need to break any more. For a closed contour, we can find the two points that lie farthest apart and fit two lines between them, one for one side and one for the other. Then, we can apply the recursive splitting procedure to each side. First, use a single straight line to connect the end points. Then find the edge point with the greatest distance from this straight line. Then split the straight line in two straight lines that meet at this point. Repeat this process with each of the two new lines. Recursively repeat this process until the maximum distance of any point to the poly-line falls below a certain threshold. Finally draw the lines between the vertices of an edge of the reconstructed contour to obtain the polygonal approximating contour.

III. TRIANGLE ALGORITHM

Triangle algorithm idea [4] & [10] consists in segmentation of the contour points to get triangle shape (*SP*, *B*, and *EP* points) as shown in Fig. 2. The ratio between height of the triangle (*h*) and length of the base of the triangle (*b*) is compared with the given threshold value by the equation (1).

If the ratio value is smaller than the threshold, the *EP* of the triangle is stored and *SP* is shifted to the *EP*, then a new segment is drawn. Otherwise the second point *B* is stored and the *SP* is shifted to the *B* point of the triangle. Then a new segment is drawn. The stored points determine the vertices of an edge of the approximating polygon.

$$h/b < th \quad (1)$$

where *th* is given threshold value.

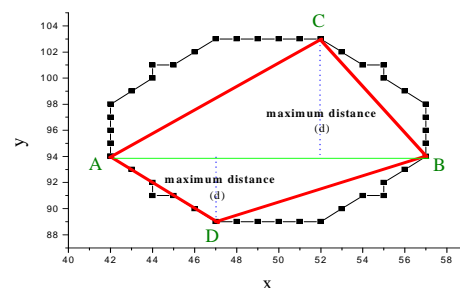

Fig. 1. Curve approximation by Ramer algorithm

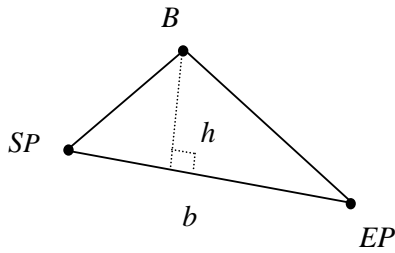

Fig. 2. Curve approximation by Triangle algorithm

IV. TRAPEZOID ALGORITHM

The idea of this algorithm consists in segmentation of the contour points to get trapezoid shapes (points of *SP*, *B*, *C*, and *EP*) [9] & [12]. The first and last points of each segment are called starting point (*SP*) and ending point (*EP*) respectively. The fit criterion is the ratio between distance between *B* and *C* points (*dBC*), and the distance between *C* and *EP* points (*dCEP*), as illustrated in Fig. 3, and is defined by equation (2). The flowchart showing the idea of Trapezoid method is shown in Fig. 4; where *VA*, *CC*, *L_{CC}*, and *f* are sequence of indices of the final vertices, sequence of the contour input, the input contour length, and the length between each two points of the trapezoid respectively.

$$(dBC / dCEP) < th \tag{2}$$

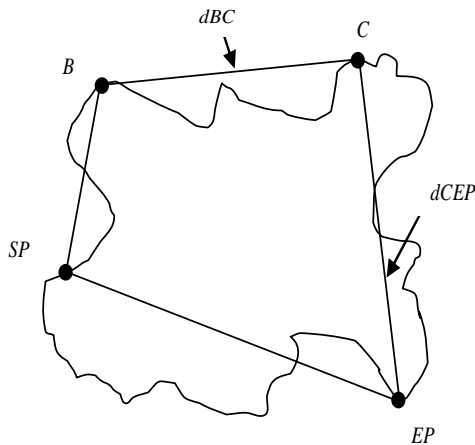

Fig. 3. Illustration of the basic trapezoid idea for the Trapezoid method.

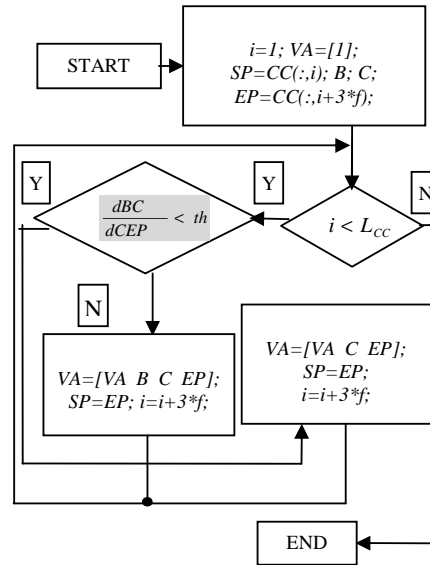

Fig. 4. Flowchart of the Trapezoid method

V. FIRST PROPOSED ALGORITHM

The idea of this method consists in segmentation of the contour points into segments. The first and last points of each segment are called starting point (*SP*) and ending point (*EP*) respectively.

The fit criterion of the analyzed method is to computing the perpendicular distance from each point along the segment to the line (*SP – EP*) as illustrated in Fig. 5. The maximum distance is compared with the given threshold value using equation (3).

$$d_{max} < th \tag{3}$$

where *th* is given threshold value.

Trigonometric formula is used to calculate these values. If *d_{max}* is smaller than the threshold, the *SP* and *EP* points of the curve segment are stored and the *SP* is shifted to the *EP*; then a new segment is drawn. Otherwise, we break the line at this point which is stored as a vertex of the polygon; and the *SP* is shifted to this point and a new segment is drawn. The idea of this curve approximation is illustrated in Fig. 5.

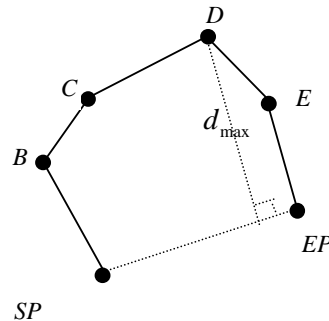

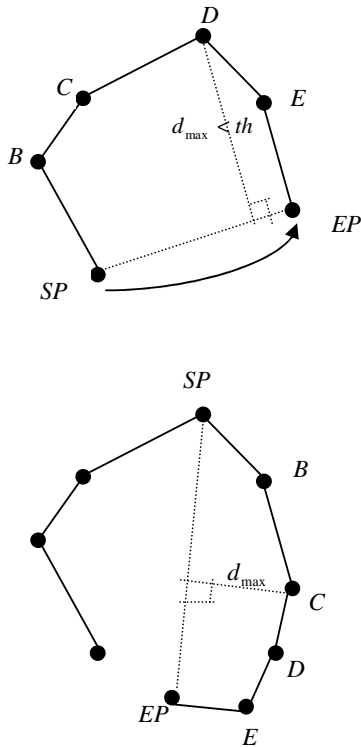

Fig. 5. Curve approximation by proposed method

from the straight line $SP-EP$, and the point which has the maximum distance in the segment. Only the co-ordinates of the first and last points of the contour segment are stored.

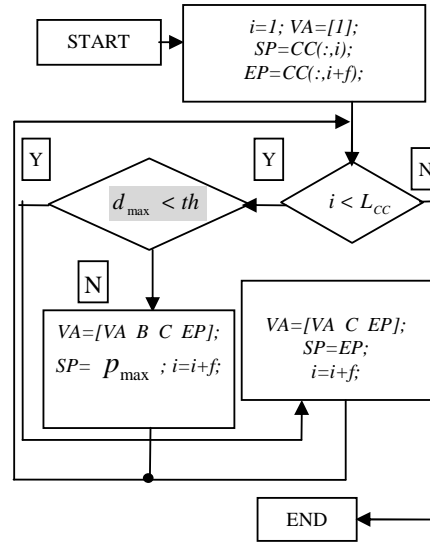

Fig. 7. Flowchart of the first Proposed method

VI. SECOND PROPOSED ALGORITHM

The main idea of this algorithm is depends on the basic criterion of Ramer algorithm which is based on the maximum distance of the curve from the approximating polygon, and this distance is used as the fit criterion. Then the Triangle method is applied. The algorithm used only the first curve approximation by Ramer algorithm as previously shown in Fig. 1, and we did not need to break any more. The points which have the maximum distances are stored as vertices of the polygonal contour. These vertices are used as input of contour points to the Triangle method. The block diagram is shown in Fig. 8.

The block diagram of the analyzed method is shown in Fig. 6.

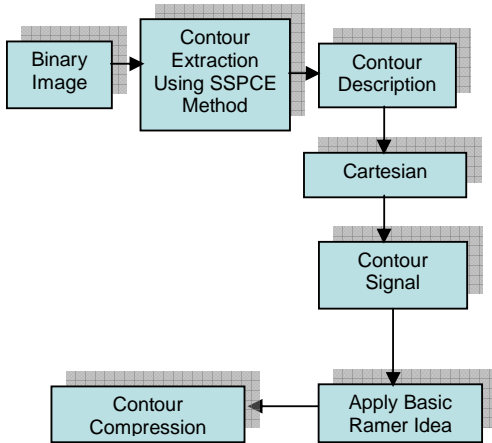

Fig. 6. Block diagram of the first proposed method

The flowchart showing the idea of this analyzed method is shown in Fig. 7; where $VA, CC, L_{CC}, f, d_{max}$ and p_{max} are sequence of indices of the final vertices, sequence of the contour input, the input contour length, the length between each SP and EP points, the furthest distance of curve point

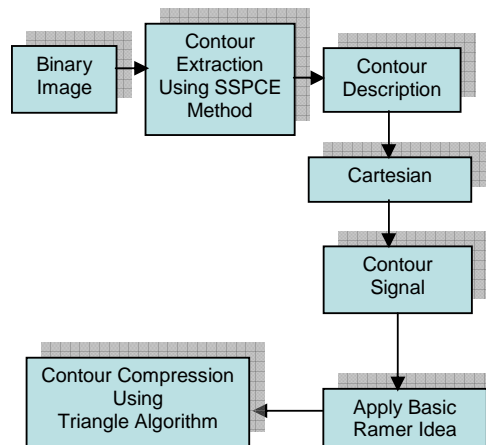

Fig. 8. Block diagram of the second proposed method

The proposed algorithms uses chain coding schemes of contour representations to determine all possible connections for both 8-connectivity and 4-connectivity schemes such as Cartesian representation, or polar representation, or generalized [8].

We used a new method of contour extraction (SSPCE) with 3x3 pixels window structure. By using the central pixel the object contours is extracted and the all possible edge direction is found which connects the central pixel with one of the remaining pixels surrounding it.

VI. APPLIED MEASURES

The compression ratio of the analyzed methods is measured using the equation (4).

$$CR = [(L_{CC} - L_{AC}) / L_{CC}] \cdot 100 \% \quad (4)$$

where L_{CC} is the input contour length, and L_{AC} is the approximating polygon length.

Quality measuring of an approximation during the approximating procedure uses mean square error (MSE) and signal-to-noise ratio (SNR) criterions by the relations (5) and (6) respectively [13] & [14].

$$MSE = (1/L_{CC}) \cdot \sum_{i=1}^{L_{CC}} d_i^2 \quad (5)$$

where d_i is the perpendicular distance between i point on the curve segment and straight line between each two successive vertices of that segment.

$$SNR = -10 \cdot \log_{10} (MSE / VAR) \quad (6)$$

where VAR is the variance of the input sequence.

Performed analysis and experiments show that SNR should be greater than 32 dB to obtain the expected compromise between compression ratio and quality of reconstruction. In the case of high threshold level, the contour details are eliminated and level of introduced distortion can not be accepted.

VII. RESULTS OF THE EXPERIMENTS

To visualize the experimental results a set of two test contours are selected. Selected contours are shown in Fig. 9. First contour is Roses and it consists of (4596) points; while the second contour is Thanks and it consists of (2046) points. Some selected results of Roses contour are shown in Fig. 10 and related results are in Table 1; where NO is the number of operations (i.e. number of arithmetic operations which are performed such as addition, multiplication, division, etc). Some selected results of the Thanks contour are shown in Fig. 11 (related results are in Table 2).

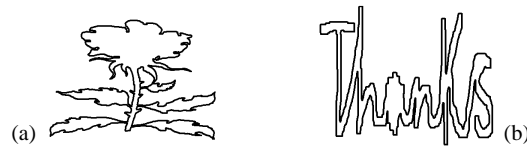

Fig. 9. Test contours: a) Roses, b) Thanks

Method	MSE	SNR	CR [%]	NO
a) Proposed I	6.93	34.52	96.06	82465
b) Ramer	3.25	37.81	96.02	353218
c) Triangle	9.00	33.41	96.06	5205
d) Proposed II	8.12	33.84	96.00	4249
e) Trapezoid	11.86	32.19	96.01	1658

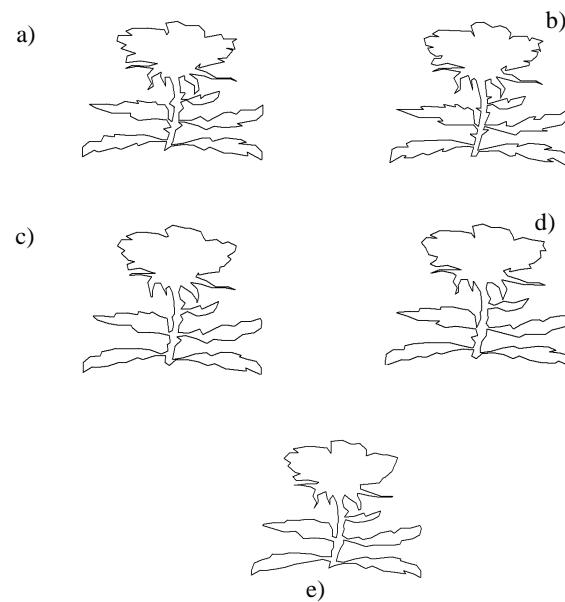

Fig. 10. Roses contour approximations results

Method	MSE	SNR	CR [%]	NO
a) Proposed I	1.47	38.91	94.38	35381
b) Ramer	0.60	43.02	94.38	158005
c) Triangle	2.80	36.09	94.38	3205
d) Proposed II	3.32	35.36	94.33	2724
e) Trapezoid	4.28	34.25	94.43	1007

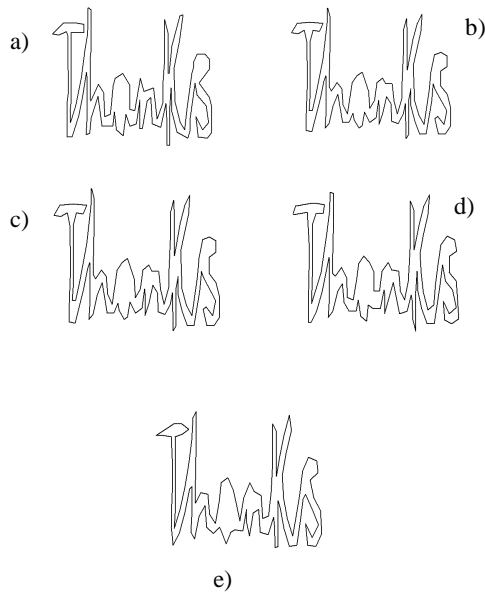

Fig. 11. Thanks contour approximations results

The results presented in Figs. 10 and 11 show that the proposed methods have good compression abilities. It is seen that the compression ratio for some type of contours can be even greater than or equal to 96%. Comparison of the compression abilities of the analyzed methods and the Ramer, Triangle and Trapezoid methods are presented for the tested contours.

Plots for Roses and Thanks contours of MSE, SNR, and NO versus CR are shown in Fig. 12, Fig. 13 and Fig. 14 respectively.

The plots show that SNR using both analyzed algorithms is less than Ramer and better than Triangle and Trapezoid methods by about 2 decibel for higher compression of contours. But the number of the operations using Ramer method is much higher than in the analyzed methods for many different shapes of contours.

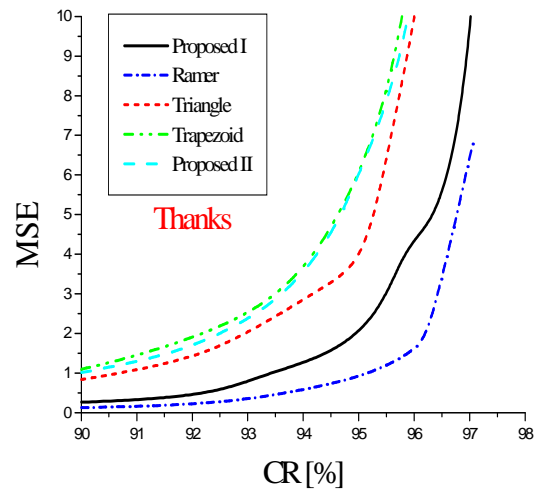
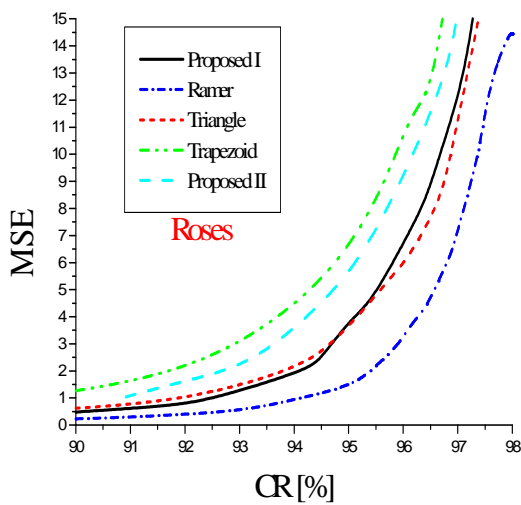

Fig. 12. Comparison of the analyzed method with Ramer, Triangle and Trapezoid methods for MSE versus CR for the tested contours

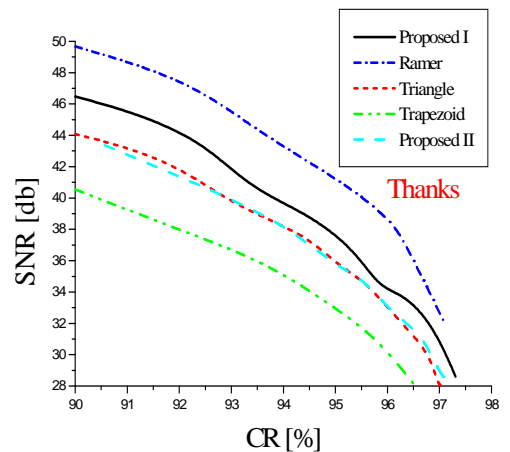
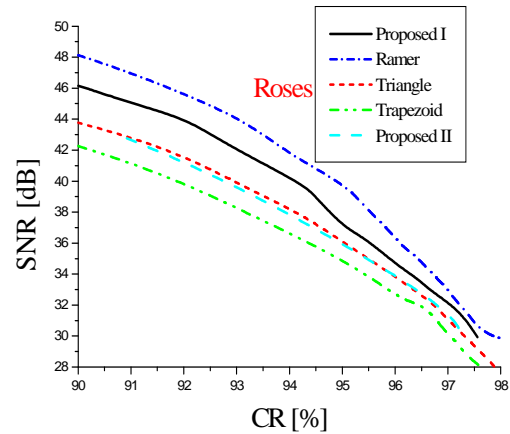

Fig. 13. Comparison of the analyzed method with Ramer, Triangle and Trapezoid methods for SNR versus CR for the tested contours

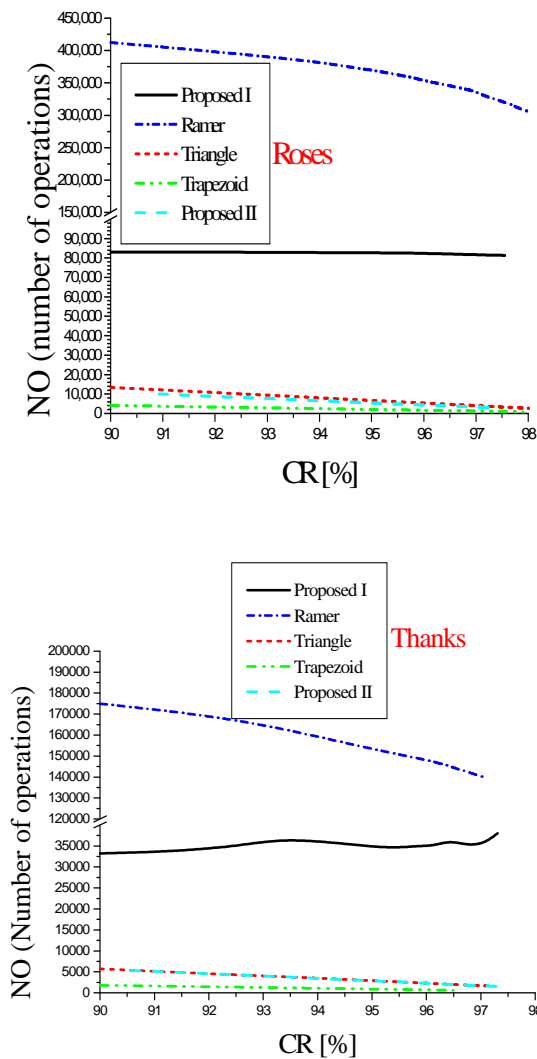

Fig. 14. Comparison of the analyzed method with Ramer, Triangle and Trapezoid methods for NO versus CR for the tested contours

VII. CONCLUSION

In this paper, we have presented a two new scheme of contour compression. In this work, some of the spatial methods of contour compression (Ramer, Triangle and Trapezoid) are discussed and compared with the analyzed methods. The drawbacks and advantages of the methods were discussed in detail. The compression ratio obtained by these new algorithms can be greater than or equal to 96% with accepted significant visible distortion. The presented results show that the proposed algorithms for contour approximation are many times faster than Ramer method. Triangle and Trapezoid methods is faster than Ramer and Proposed methods, but the quality is not. The proposed methods give better quality about two decibels than Triangle and Trapezoid methods. To obtain higher compression ratio with small significant visible distortion in the reconstruction quality; the accepted level of the reconstruction quality is

determined. The threshold is the maximum number of points between each two points in the segment shape with the conservation of the accepted level of the reconstruction quality. The proposed algorithm also has a low complexity compared to Ramer method. This study concludes that the methods proposed gives higher compression for contours with some small significant losses of contour approximation quality.

REFERENCES

- [1] Dziech A., Besbas W. S., Nabout A. and Nour Eldin H. A., "Fast algorithm for closed contour extraction", *Proc. of the 4th International Workshop on Systems, Signals and Image Processing*, Poznań, Poland, pp. 203-206, 1997.
- [2] Sklansky J. and Gonzalez V., "Fast polygonal approximation of digitized curves", *Pattern Recognition*, Volume 12, Issue 5, pp. 327-331, 1980.
- [3] Ramer U., "An iterative procedure for the Polygonal approximation of plane curves", *Computer Graphics and Image Processing*, Academic Press, Volume 1, Issue 3, pp. 244-256, 1972.
- [4] Dziech A., Ukasha A. and Baran R., "Fast method for contour approximation and compression", *WSEAS Transaction on communications*, Volume 5, Issue 1, pp. 49-56, 2006.
- [5] Baran R., and Dziech A., "Tangent method and the other efficient methods of contour compression", *WSEAS Transactions on Computers*, Volume 4, Issue 7, pp. 805-813, 2005.
- [6] Zhu P. and Chirlian P. M., "On critical point detection of digital shapes", *IEEE Transaction on Pattern Analysis and Machine Intelligence*, Volume 17, Issue 8, pp. 737-748, 1995.
- [7] Batchelor B. G. and Laing S. G., "Polar-vector representations of edges in Pictures", *Electronics Letters*, Volume 13, Issue 24, pp. 727-729, 1977.
- [8] Jain A. K., "*Fundamentals of Digital Image Processing*", Englewood Cliffs, NJ: Prentice-Hall, 1989.
- [9] Ukasha A., Dziech A., Elsharif E. and Baran R., "An efficient method of contour compression", *International Conference on Visualization, Imaging and Image Processing (IASTED/VIIP)*, Cambridge, United Kingdom, pp. 213-218, 2009.
- [10] Ukasha A., Dziech A. & Baran R., "A New Method For Contour Compression", *WSEAS Int. Conf. on Signal, Speech and Signal Processin (SSIP 2005)*, Corfu Island, Greece, pp. 282-286, 2005.
- [11] Dziech A., Baran R. & Ukasha A., "Contour compression using centroid method", *WSEAS Int. Conf. on Electronics, Signal Processing and Control (ESPOCO 2005)*, Copacabana, Rio de Janeiro, Brazil, pp. 225-229, 2005.
- [12] Ukasha A., "Arabic Letters Compression using New Algorithm of Trapezoid method", *International Conference on Signal Processing, Robotics and Automation (ISPRA'10)*, Cambridge, United Kingdom, 336-341, 2010.
- [13] Gonzalez R. C., "*Digital Image Processing*", Second Edition, Addison Wesley, 1987.
- [14] Besbas W., "Contour Extraction, Processing and Recognition", Poznan University of Technology, Ph. D. Thesis, 1998.