

Power Flow Control with UPFC in Power Transmission System

Samina Elyas Mubeen, R. K. Nema, and Gayatri Agnihotri

Abstract—In this paper the performance of unified power flow controller is investigated in controlling the flow of power over the transmission line. Voltage source model is utilized to study the behaviour of the UPFC in regulating the active, reactive power and voltage profile. This model is incorporated in Newton Raphson algorithm for load flow studies. Simultaneous method is employed in which equations of UPFC and the power balance equations of network are combined in to one set of non-linear algebraic equations. It is solved according to the Newton raphson algorithm. Case studies are carried on standard 5 bus network. Simulation is done in Matlab. The result of network with and without using UPFC are compared in terms of active and reactive power flows in the line and active and reactive power flows at the bus to analyze the performance of UPFC .

Keywords—Newton-Raphson algorithm, Load flow, Unified power flow controller, Voltage source model.

I. INTRODUCTION

FLEXIBLE AC transmission system is an evolving technology based solution to help electric utilities fully utilize their transmission assets. Its first concept was introduced by N.G Hingorani, in 1988[15]. Since then different kinds of FACTS devices have been proposed. Among them the UPFC is the most versatile and effective device which was introduced in 1991[6, 7]. The UPFC consist of voltage source converters, one connected in series and other in shunt and both are connected back to back through a D.C capacitor [7]. In order to investigate the impact of UPFC on power systems effectively, it is essential to formulate their correct and appropriate model. In the area of power flow analysis models of the UPFC have been published[3,10,12,14,17] which treat the UPFC either as one series voltage source and one shunt current source model or both the series and the shunt are represented by voltage sources.[12] presented a decoupled model which is simple to implement but it presents some restrictions[2]. In [4] the UPFC is represented by two voltage sources called the voltage source model (VSM) [3] discusses the distinguishing features of the voltage source model at length.[7, 11, 16] introduced another model called the power injection models (PIM). Taking these two models as the base models, few other models [1, 9, 10, 14, 17] have been developed with slight modifications in order to circumvent the limitations of the base models.

Samina Elyas Mubeen is with Maulana Azad NIT, Bhopal, India (e-mail:saminaem@yahoo.com).

In this paper voltage source model of UPFC is incorporated in Newton Raphson algorithm in order to investigate the control of power flow. Normally there are two ways of solving the load flow equations with UPFC. The sequential method and the simultaneous method: In sequential method the equations of UPFC are separated from the system power balance equations.

Both the set of equations are solved separately and sequentially. In simultaneous method all the equations are combined in to one set of non-linear algebraic equations. A jacobian matrix is then formed which is non symmetric in nature. The simultaneous method is used in this paper.

II. OPERATING PRINCIPAL OF UPFC

The two voltage source converters of the UPFC, connected through a D.C link can be modeled as two ideal voltage sources, one connected in series and the other in shunt between the two buses [2, 4]. The output of the series voltage source V_{se} and θ_{se} are controllable magnitude and angle between the limits $V_{semax} \leq V_{se} \leq V_{semin}$ and $0 \leq \theta_{se} \leq 2\pi$ respectively and of the shunt voltage source is V_{sh} and θ_{sh} controllable between the limits $V_{shmax} \leq V_{sh} \leq V_{shmin}$ and $0 \leq \theta_{sh} \leq 2\pi$. Fig. 1 shows the voltage source model of UPFC. Z_{se} and Z_{sh} are the impedances of the two coupling transformer one connected in series and other in shunt between the line and the UPFC.

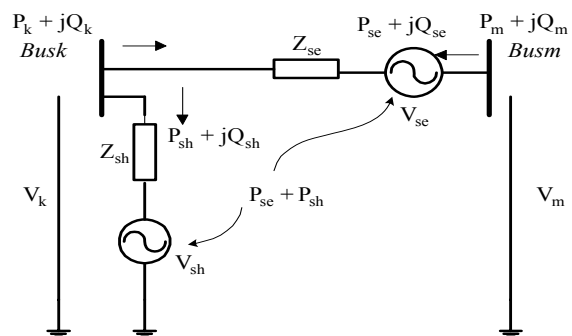

Fig. 1 Voltage source model of UPFC

The converter output voltage (magnitude and angle) is used to control the mode of power flow and voltage at the nodes as follows:

- i) The bus voltage magnitude can be controlled by injecting a voltage V_{se} in phase or antiphase as shown in the Fig 2. (θ_{se} is in phase/antiphase with the nodal voltage angle θ_k)
- ii) Power flow can be controlled (Series reactive compensation) by injecting a voltage V_{se}' in quadrature (lead or lag) to the line current ($\theta_{se} = \gamma_m \pm 90$, γ_m is the angle between V_m and I_m) Fig. 2.
- iii) Power flow can be controlled (as phase shifter) by injecting a voltage of magnitude $1(V_{se}''$) in quadrature (lead or lag) to node voltage θ_m - Fig. 2.

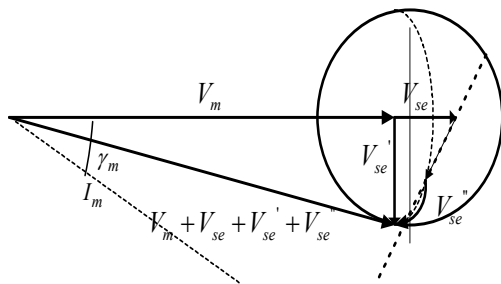

Fig. 2 Simultaneous control of voltage, impedance & angle

III. MATHEMATICAL REPRESENTATION OF UPFC

The two ideal voltage sources of the UPFC can be mathematically represented as:

$$V_{se} = V_{se} (\cos \theta_{se} + j \sin \theta_{se}) \quad (1)$$

$$V_{sh} = V_{sh} (\cos \theta_{sh} + j \sin \theta_{sh}) \quad (2)$$

UPFC is connected between two buses k and m in the power system. Applying the kirchoff's current and voltage laws for the network in Fig. 1 gives:

$$\begin{bmatrix} I_k \\ I_m \end{bmatrix} = \begin{bmatrix} y_{se} + y_{sh} & -y_{se} & -y_{se} & -y_{sh} \\ -y_{se} & y_{se} & y_{se} & 0 \end{bmatrix} \begin{bmatrix} V_k \\ V_m \\ V_{se} \\ V_{sh} \end{bmatrix} \quad (3)$$

where $y_{se} = \frac{I}{z_{se}}$ and $y_{sh} = \frac{I}{z_{sh}}$

The element of transfer admittance matrix can be put as

$$\begin{bmatrix} Y_{kk} = G_{kk} + jB_{kk} = y_{se} + y_{sh} \\ Y_{mm} = G_{mm} + jB_{mm} = y_{se} \\ Y_{km} = Y_{mk} = G_{km} + jB_{km} = -y_{se} \\ Y_{sh} = G_{sh} + jB_{sh} = -y_{sh} \end{bmatrix} \quad (4)$$

The UPFC converters are assumed lossless in this voltage sources model. This implies that there is no absorption or generation of active power by the two converters for its losses and the active power demanded by the series converter at its output is supplied from the AC Power system by the shunt converters via the common D.C link. The DC link capacitor voltage V_{dc} remains constant. Hence the active power supplied to the shunt converter P_{sh} must be equal to the active power demanded by the series converter P_{se} at the DC link. Then the following equality constraint has to be guaranteed.

$$P_{se} + P_{sh} = 0 \quad (5)$$

From Fig. 1 and by (1), (2), (3) for the series and shunt sources the power equations of UPFC can be written

$$P_{se} = V_{se}^2 G_{mm} + V_{se} V_k (G_{km} \cos(\theta_{se} - \theta_k) + B_{km} \sin(\theta_{se} - \theta_k)) + V_{se} V_m (G_{mm} \cos(\theta_{se} - \theta_m) + B_{mm} \sin(\theta_{se} - \theta_m)) \quad (6)$$

$$P_{sh} = -V_{sh}^2 G_{sh} + V_{sh} V_k (G_{sh} \cos(\theta_{sh} - \theta_k) + B_{sh} \sin(\theta_{sh} - \theta_k)) \quad (7)$$

IV. IMPLEMENTATION OF UPFC IN NEWTON RAPHSON POWER FLOW ALGORITHM

The algorithm for solving a power flow problem embedded with UPFC is implemented by using the MATLAB programming.

The Newton Raphson load flow algorithm incorporating the UPFC is shown by flow chart in Fig. 3. The input system data includes the basic system data needed for conventional power flow calculation consisting of the number and types of buses, transmission line data, generation and load data, location of UPFC and the control variables of UPFC i.e the magnitude and angles of voltage output V_{se} and V_{sh} of two converters. The inclusion of the UPFC increases one bus in the system. The UPFC power equations are combined with the network equations to give equation (8):

$$P_i + jQ_i = \sum_{j=1}^n V_i V_j Y_{ij} \angle(\theta_{ij} - \delta_i + \delta_j) + P_i' + jQ_i' \quad (8)$$

Where $P_i' + jQ_i'$ = active and reactive power flow due to UPFC between the bus k and m .

$P_i + jQ_i$ = Active and reactive power at the i^{th} bus.

$V_i \angle \delta_i$ = Voltage and angle of i^{th} bus, $V_j \angle \delta_j$ = Voltage

and angle of j^{th} bus. Y_{ij} = admittance of the transmission line between the bus i and j . Eq. (8) is linearised with respect to the variables of the network and the UPFC. The power flow constraint of the UPFC is included in the jacobian. The inclusion of these variables increases the dimension of the jacobian. The power equations are mismatched until convergence is achieved. A scalar multiplier is used to control the updating of variables to ensure that they converge in an optimal way to the solution point.

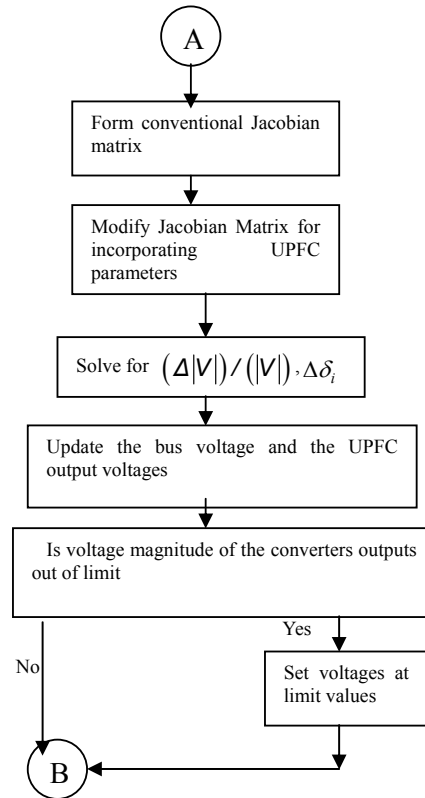
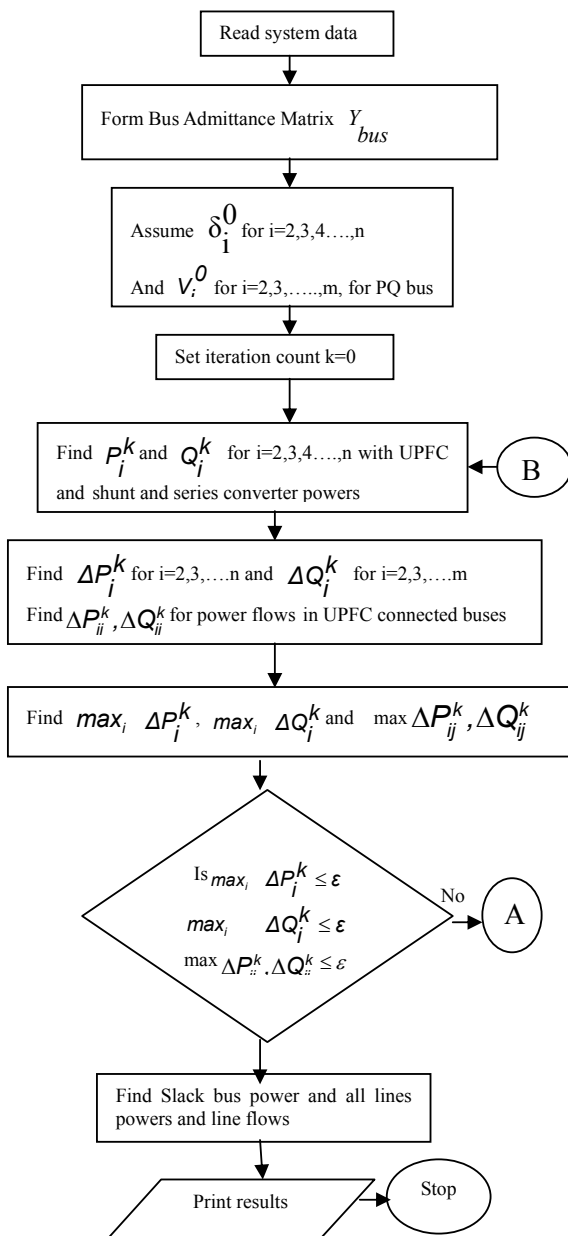

Fig. 3 Flow Chart for load flow by N-R with UPFC

V. OPTIMAL MULTIPLIER TECHNIQUE FOR CONVERGENCE

The Newton Raphson method fails to converge when working with automatic controls and heavily loaded system. Step size adjustment (optimal multiplier) technique is employed in order to improve the convergence property []. In Newton raphson method the power balance constraints at any bus *k* of an *n* bus system ,incorporating the voltage source model of the UPFC , take the form as in equation(8).

These equations can be represented as $S = f(x) = 0$ where *x* is vector of unknown, voltage and angle at each bus. The power flow attempts to solve:

$$f(x) = 0 \tag{9}$$

The taylor series expansion of (9) about the solution x^s at iteration *t* is

$$f(x^s) = f(x^t + \Delta x^t) = f(x^t) + J(x^t) \Delta x^t + \text{higher terms} \tag{10}$$

Higher order terms are neglected here. Since $f(x^s) = 0$ by definition. Hence

$$\Delta x^t = -[J(x^t)]^{-1} f(x^t) \tag{11}$$

This result updates the current solution estimates. Thus

$$x^{t+1} = x^t + \Delta x^t \tag{12}$$

or

$$x^{t+1} = x^t + \mu \Delta x^t \tag{13}$$

Instead of Eq(12), (13) is used where μ is scalar multiplier used to ensure the convergence in an optimal manner. The mismatch at iteration $t+1$ can be written as

$$f(x^{t+1}) = f(x^t + \mu \Delta x^t) = f(x^t) + \mu J(x^t) \Delta x^t \tag{14}$$

Alternatively, the expression

$$C = \frac{1}{2} f^T(x) f(x) \tag{15}$$

defines a cost function that approaches zero as the system nears a solution. Differentiating (15) with respect to μ yields the adjustment factor to use in evaluating $x^{t+1} = x^t + \mu \Delta x^k$. This technique is utilized in achieving convergence below.

VI. TEST CASE AND SIMULATION

Standard 5 bus test network is tested with and without UPFC to investigate its behaviour. In the analysis bus 1 is taken as slack bus, 2 and 3 are voltage control buses and 4, 5 are load buses. To include the UPFC in the network an additional bus (bus no 6) is introduced as shown. The UPFC shunt converter is set to regulate node 3 voltage magnitude at 1 pu while series converter regulates the power flow between the two nodes. Flat voltage start is assumed for the two UPFC voltage sources.

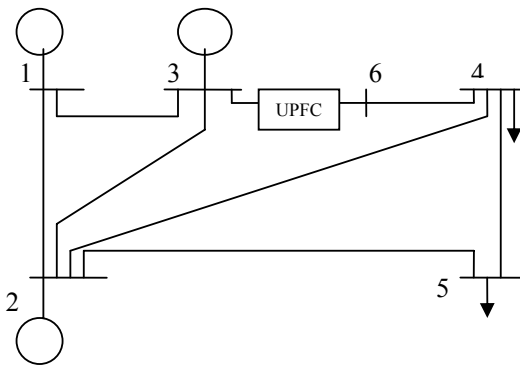

Fig. 4 Single line Diagram of 5-Bus System

Test Data is given in Table below.

TABLE I
BUS DATA

Bus no.	Voltage (v ,θ)	Load (MW, Mvar)	Generator		Injected MVAR
			(MW, Mvar)	Qmin, Qmax	
1	1.06, 0	0, 0	0, 0	10, 50	0
2	1.045, 0	20, 10	40, 30	10, 50	0
3	1.03, 0	20, 15	30, 10	10, 40	0
4	1.00, 0	50, 30	0, 0	0, 0	0
5	1.00, 0	60, 40	0, 0	0, 0	0
6	--	30, 2	--	--	--

TABLE II
LINE DATA

Sending Bus	Receiving Bus	Line resistance pu	Line reactance pu	Line susceptance pu
1	2	0.02	0.06	0.06
1	3	0.08	0.24	0.05
2	3	0.06	0.18	0.040
2	4	0.06	0.18	0.040
2	5	0.04	0.12	0.030
3(6)	4	0.010	0.03	0.020
4	5	0.08	0.24	0.050

VII. RESULT OF SIMULATION

The test network was tested without UPFC and with UPFC. For the network without UPFC the convergence was achieved in 5 iterations to a power mismatch tolerance of 10^{-8} . With UPFC convergence was achieved in 7 iteration for the same tolerance. Also, the UPFC parameters were within limits. The simulation yields the power flow for lines and bus active and reactive powers which are tabulated below. The voltages of the buses with and without UPFC are also reported.

TABLE III
LINE FLOWS WITH AND WITHOUT UPFC

Line No.	Line Flows without UPFC		Line Flows with UPFC	
	P (MW)	Q (MVAR)	P (MW)	Q (MVAR)
1-2	-0.86846	-0.72908	0.62159	-0.033818
1-3	-0.40273	-0.17513	-0.2182	-0.16687
2-3	-0.24473	-0.003523	-0.09018	-0.209
2-4	-0.27252	-0.008305	-0.20618	-0.22702
2-5	-0.53445	-0.048292	-0.51226	-0.3839
3-4	-0.19346	-0.06555	-0.40836	-0.02
4-5	-0.04687	-0.051708	-0.09804	-0.0138

TABLE IV
BUS POWERS WITH AND WITHOUT UPFC

Bus No.	Bus Power Without UPFC		Bus Power with UPFC	
	P (MW)	Q (MVAR)	P (MW)	Q (MVAR)
1	1.3112	0.90816	0.8401	0.20087
2	0.4	-0.61593	0.4	0.84472
3	-0.45	-0.15	-0.1	-0.298
4	-0.4	0.05	-0.5	-0.3
5	-0.6	-0.1	-0.6	-0.4
6	-	-	0.3	0.02

It is clearly seen from the Table IV that the power of the 4th bus is increased due to the insertion of UPFC powers. The line flow in the line between bus 3-4 has increased from -0.19346 to -0.40836. The negative sign shows the direction of power flow from the shunt converter end to the series converter end. The voltage of the buses with and without UPFC is tabulated below. The UPFC is worked to set the third bus voltage to 1 per unit.

TABLE V
BUS VOLTAGE WITH AND WITHOUT UPFC

Bus no	Voltage without UPFC		Voltage with UPFC	
	V	θ rad	V	θ rad
1	1.06	0	1.06	0
2	1.045	-2.4511	1.045	-1.8596
3	1.03	-4.2611	1.00	-1.9955
4	1.0186	-4.6548	0.99051	-3.0883
5	0.98999	-5.3176	0.98021	-4.4388

VIII. CONCLUSION

Voltage source model is used in this paper to investigate the functioning of UPFC. The model is incorporated in Newton Raphson Algorithm for load flow studies. The Numerical result for the standard 5 bus network has been presented with and without UPFC and compared. It was found that the UPFC regulates the voltage of the bus as well as regulates the active and reactive power of the buses and the lines within specified limits. The algorithm is capable of regulating the power flow and voltage singly as well as simultaneously.

REFERENCES

- [1] Abbate.L, M. Trovato, C. Becker and E.Handschin, "Advanced Steady-State Models of UPFC for Power System Studies IEEE 2002 pp.449-454.
- [2] Fuente-Esquivel C.R, E. Acha "Unified power flow controller: a critical comparison of Newton-Raphson UPFC algorithms in power flow studies" IEE Proc.-Gener. Transm. Distrib., Vol. 144, No. 5, September 1997
- [3] Fuente-Esquivel, C.R, and Acha, E.: 'Incorporation of UPFC model in an optimal power flow using Newtons method', IEE Proc. -Gen-Transm.Distrib.,Vol145,No.3 May1998, 1998, pp336-344,
- [4] Fuente-Esquivel C.R., E. Acha, H. Ambriz-Pérez, comprehensive Newton-Raphson UPFC model for the quadratic power flow solution of practical power networks', IEEE Trans. on Power Systems, Vol. 15, No. 1, Feb. 2000, pp. 102-109.
- [5] Fuente-Esquivel C.R. and E.Acha "Newton-Raphson algorithm for the reliable solution of large power networks with embedded FACTS" IEE Proc.-Ganev. Tvansnr. Distrib., Vol. 143, No. 5, September 1996 pp 447-454.
- [6] Gyugyi, L."Unified power flow controller concept for flexible AC Transmission system", IEE Proceedings-C vol-139,no.4,pp 323-331 July 1992.
- [7] Gyugyi, L,et al."The unified power flow controller: A new Approach to power transmission control", IEEE Trans on Power DELivery vol,10,No.2,pp1085-1097 April 1995.
- [8] Hingorani N. G, 'High Power Electronics and Flexible AC Transmission System', IEEE Power Engineering Review, July 1988, pp. 3-4.
- [9] Mehmet Tumay , A. Mete Vural" Analysis and Modeling of Unified Power Flow Controller: Modification Of Newton-Raphson Algorithm And User-Defined Modeling Approach For Power Flow Studies" The Arabian Journal for Science and Engg, Volume 29, Number October 2004 pp 135-151.
- [10] Noroozian, M., Angquist, L., Ghandhari, M., And Anderson, G: 'Use of UPFC for optimal power flow control'. IEEE iKTH Stockholm Power tech conference, Stockholm, Sweden, 1995, pp 506-511.
- [11] Nabavi-Niaki, A., And Iravani, M.R.: 'Steady-state and dynamic models of unified power flow controller (UPFC) for power system studies'. Presented at 1996 IEEE iPES Winter Meeting, Baltimore, 1996 pp. 447-454.
- [12] A. Nabavi-Niaki, M.R. Iravani, 'Steady-state and dynamic models of Unified Power Flo IEEE Trans. on Power Systems, Vol. 11, No. 4, Nov. 1996, pp. 1937-1943.
- [13] A.M Vural and M.Tumay, "Steady State Analysis of Unified Power flow controller: Mathematical Modeling and Simulation studies" in Proceedings of the IEEE Power tech Conference June 23-, Bologna, Italy, 2003.
- [14] Y. H. Song, J.Y. Liu, P.A. Mehta, 'Power injection modeling and optimal multiplier power flow algorithm for steady-state studies of unified power flow controllers', Electric Power System Research, Vol.52,1999, pp.51-59.
- [15] Ying Xiao Y.H.Song, Y.Z. Sun, "Power Injection Method and Linear Programming for FACTS Control" in proceeding of IEEE -7803-5935-6/00/\$10.00 (c) 2000.
- [16] Seyed Ali Nabavi-Niaki, M. R. Iravani, "Visualization and Investigation of Unified Power Flow Controller (UPFC) Non-linearity in Power Flow" in the proceedings of IEEE 2003 pp 812-817.
- [17] Nemat-Talebi et al, "An efficient Power injection modeling and sequential power flow Algorithm for FACTS Devices", IEEE 0-7803 2004 IEEE.
- [18] Stagg, N.G., and El-Abiad, H.A.: 'Computer methods in power system analysis' (McGraw-Hill Inc., 1968).
- [19] Tate J.E and Thomas J.Overbye, "A Comparison of the Optimal Multiplier in Polar and Rectangular Coordinates" IEEE Transactions on Power systems, Vol.20,No 4, November 2005.