

Fuzzy C-Means Clustering Algorithm for Voltage Stability in Large Power Systems

Mohamad R. Khaldi, Christine S. Khoury, Guy M. Naim

Abstract—The steady-state operation of maintaining voltage stability is done by switching various controllers scattered all over the power network. When a contingency occurs, whether forced or unforced, the dispatcher is to alleviate the problem in a minimum time, cost, and effort. Persistent problem may lead to blackout. The dispatcher is to have the appropriate switching of controllers in terms of type, location, and size to remove the contingency and maintain voltage stability. Wrong switching may worsen the problem and that may lead to blackout. This work proposed and used a Fuzzy C-Means Clustering (FCMC) to assist the dispatcher in the decision making. The FCMC is used in the static voltage stability to map instantaneously a contingency to a set of controllers where the types, locations, and amount of switching are induced.

Keywords—Fuzzy logic, Power system control, Reactive power control, Voltage control

I. INTRODUCTION

SCHEDULED maintenance, natural forces, severe load variations, and/or outages are classified as disturbances that often cause electromechanical oscillations [1] and can drive a power system to an abnormal steady state operation. Following a disturbance, a power system's stable steady state operating condition is disrupted. Stability here is in reference to the bus voltage profile being within the prescribed $1 \pm 5\%$ pu operational limits.

Reactive power compensation devices are placed in key locations so that they can be used to control the bus voltage profile. An operation engineer (or a dispatcher) coordinates the compensation devices when a disturbance causes the system's operating state to shift to an unstable but controllable state. Therefore, one of the most important problems facing power utilities is to coordinate the reactive power compensation devices to maintain an acceptable bus voltage profile while keeping operational cost minimum and assuring system's stability to disturbances. In practice, the dispatcher makes a decision on the location and the number of compensators to be rescheduled and also the amount of compensation needed. The sequence, the timing, and the amount of switching are critical to avoiding damaging devices that ultimately leads to voltage collapse. Therefore, an Artificial Intelligent (AI) is in justifiable need to aid in the decision-making process.

Mohamad R. Khaldi is with the Electrical Engineering Department, University of Balamand, Tripoli, Lebanon (phone: 961-6-930250 ext. 3455; fax: 961-6-930278; e-mail: mohamad.khaldi@balamand.edu.lb).

Christine S. Khoury, the Electrical Engineering Department, University of Balamand, Tripoli, Lebanon (e-mail: christine.khoury@std.balamand.edu.lb).

Guy M. Naim is with the Electrical Engineering Department, University of Balamand, Tripoli, Lebanon (e-mail: guy.naim@std.balamand.edu.lb).

Numerical optimization techniques have been used in power systems planning, contingency analysis, and control [2]-[4]. However, classical techniques are limited only to problems that they are quantitative in nature. On the other hand, AIs are systems who are capable of handling quantitative and qualitative problems [5]. The transformation of knowledge coupled with data processing is the quintessence of what is so called a Knowledge-Based System (KBS). Accordingly, a KBS is chosen as a Computer-Aided Software Tool (CAST) to aid the operator in reaching a remedial action to the voltage problem. KBS, as one form of AI, are used in power systems for load management and voltage stability [6],[7]. Another form of AI is Artificial Neural Network (ANN) who has gained popularity and is used in various domains. Security assessment [8], voltage prediction problem [9], and load forecasting [10] are few examples of ANN applications to power systems. Recently ANN is used online for the static voltage stability problem [11].

There have been many applications of fuzzy systems to reactive power control and voltage stability problems. A Fuzzy system is used to ensure voltage security of power system by predicting the nearness of voltage failure for a giving load condition. It aids in determining the maximum loadability without causing voltage instability and is used to detect the critical lines for a specific load to monitor prior to experiencing line outage [12]. Narendranath Udupa et al [13] presented an approach where voltage stability index and controlling variables are translated into fuzzy set notations to formulate the relation between voltage stability level and controlling ability of controlling devices.

Another approach is used by [14] to find a solution which takes both voltage security improvement and loss reduction into account for an electric power system. This approach uses linearized model to translate violation level of buses voltage and controlling ability of controlling devices into fuzzy set notations. nA knowledge-based system for supervision and control of regional voltage profile and security using fuzzy logic is presented by [15]. In this approach, control strategies are defined by the system operators based on their experience and on off-line studies, which are translated into rules of a hierarchical fuzzy inference system.

II. PROBLEM FORMULATION

A. Power System Network Model

The admittance matrix of the interconnected power system, \mathbf{Y}_{bus} , can be constructed by

$$\mathbf{Y}_{bus} = \Delta \left(\Sigma \left(\mathbf{Y}_{prn} \quad \mathbf{Y}_{chg} \right) \right) \quad \mathbf{Y}_{prn} \quad (1)$$

where, for an $n \times n$ square matrix \mathbf{A} , then $\mathbf{B} = \Sigma(\mathbf{A})$ is an $n \times 1$ vector whose elements are the sum of the corresponding rows of \mathbf{A} . Furthermore, $\mathbf{C} = \Delta(\mathbf{B})$ is an $n \times n$ diagonal matrix whose diagonal elements are the elements of $n \times 1$ vector \mathbf{B} . Furthermore, \mathbf{Y}_{pm} and \mathbf{Y}_{chg} are the primary and the half charging matrices, respectively.

Using the vectorized approach, the mismatch power equation

$$\mathbf{S}_{\text{bus}} = \Delta(\mathbf{V}_{\text{bus}}) \mathbf{Y}_{\text{bus}}^* \mathbf{V}_{\text{bus}}^* \quad (2)$$

where $\mathbf{S}_{\text{bus}} = \mathbf{P}_{\text{bus}} + j\mathbf{Q}_{\text{bus}} \in \mathbb{C}^{n \times 1}$ is the total injected complex power and $\mathbf{V}_{\text{bus}} = |\mathbf{V}_{\text{bus}}| e^{j\boldsymbol{\delta}_{\text{bus}}} \in \mathbb{C}^{n \times 1}$ is the voltage profile. Equation (2) represents a vectorized set of highly coupled nonlinear equations. Thus, the power flow problem is to solve (2) for the PQ-bus voltage profile, the required reactive power for the PV buses, and the complex power for the slack bus. Thus far, analytical solution to (2) has not found yet! Normally, numerical methods are used to find a solution - if it exists. Newton-Raphson method, a fast and an efficient numerical approach that is commonly used to solve (2), is based upon the Taylor series expansion with respect to the voltage magnitudes and the voltage phase angles about a nominal steady-state operating point,

$$d\mathbf{S} = \frac{\partial \mathbf{S}}{\partial |\mathbf{V}|} d|\mathbf{V}| + \frac{\partial \mathbf{S}}{\partial \boldsymbol{\delta}} d\boldsymbol{\delta} + h.o.t. \quad (3)$$

Note that the subscripts $(\bullet)_{\text{bus}}$ are neglected for simplicity. Separating real and imaginary parts and collecting terms, (3) expressed in a matrix-vector form results in,

$$\begin{bmatrix} d\mathbf{P} \\ d\mathbf{Q} \end{bmatrix} = \underbrace{\begin{bmatrix} \mathbf{J}_{P\delta} & \mathbf{J}_{P|V|} \\ \mathbf{J}_{Q\delta} & \mathbf{J}_{Q|V|} \end{bmatrix}}_{\mathbf{J}} \begin{bmatrix} d\boldsymbol{\delta} \\ d|\mathbf{V}| \end{bmatrix} + h.o.t. \quad (4)$$

Where, $\mathbf{J}_{xy} \triangleq \frac{\partial \mathbf{x}}{\partial \mathbf{y}} \in \mathbb{C}^{n \times n}$. Clearly, $\mathbf{J} \in \mathbb{C}^{2n \times 2n}$ is the Jacobian

matrix whose entries are the partial derivative of the active and reactive powers with respect to the phasor voltage magnitudes and the phasor voltage angles. The sensitivity matrices of the total injected complex power with respect to magnitude and phase angle of the voltage profile are shown in (5) and (6), respectively.

$$\frac{\partial \mathbf{S}}{\partial |\mathbf{V}|} = \Delta(e^{j\boldsymbol{\delta}}) \Delta(\mathbf{Y}^* \mathbf{V}^*) + \Delta(\mathbf{V}) \mathbf{Y}^* \Delta(e^{-j\boldsymbol{\delta}}) \quad (5)$$

and

$$\frac{\partial \mathbf{S}}{\partial \boldsymbol{\delta}} = j \Delta(\mathbf{V}) \left\{ \Delta(\mathbf{V}^* \mathbf{Y}^*) - \mathbf{Y}^* \Delta(\mathbf{V}^*) \right\}. \quad (6)$$

After neglecting the higher order terms, (4) can be written as,

$$d\mathbf{X} = \mathbf{J}^{-1} d\mathbf{W} \quad (7)$$

The solution of (7) is obtained iteratively

$$\mathbf{X}(k+1) = \mathbf{X}(k) + \mathbf{J}^{-1} \Big|_k (\mathbf{W}_{\text{sch}} - \mathbf{W}|_k) \quad (8)$$

where k is the iteration index and $\mathbf{W}_{\text{sch}} \in \mathbb{R}^{2n \times 1}$ is a known vector whose entries are the scheduled complex powers and $\mathbf{W}|_k \in \mathbb{R}^{2n \times 1}$ is a vector whose entries are the calculated real and reactive powers, using (2), at the k^{th} iteration.

B. The Load-Bus Voltage Profile

The PQ or Load-Bus voltage magnitude profile computed in (8) is clearly affected by the PV or Generation-Bus voltage magnitude profile, the reactive bank compensation, and the settings of the under-load tap changing transformers. Consequently,

$$|\mathbf{V}_l| = \mathbf{f}(|\mathbf{V}_g|, \mathbf{Y}_b, \mathbf{t}) \quad (9)$$

where, $|\mathbf{V}_l| \in \mathbb{R}^{l \times 1}$ and $|\mathbf{V}_g| \in \mathbb{R}^{g \times 1}$ represent the Load-Bus and the Generation-Bus voltage magnitude profiles, respectively. $\mathbf{Y}_b \in \mathbb{R}^{b \times 1}$ and $\mathbf{t} \in \mathbb{R}^{t \times 1}$ represent the susceptance of the static reactive power (VAR) compensators and the tap settings of the under-load tap changing transformers, respectively. $|\mathbf{V}_g|$, \mathbf{Y}_b , and \mathbf{t} are viewed as the compensators or the controllers. The function in (9) is highly nonlinear and coupled set of equations and it is very difficult – if not impossible – to find analytically.

When a contingency occurs (i.e., stable but abnormal state), some of the Load-Bus voltage magnitudes fall outside an allowable operational limit of $1 \pm 5\%$ pu. The static control problem of voltage stability can be stated as follows: Select and switch a compensator or a group of compensators so that the contingency is lifted.

Fuzzy logic is trained to map a profile of controllers' settings to alleviate a contingency and to put back instantaneously the power system into operation, Fig. 1.

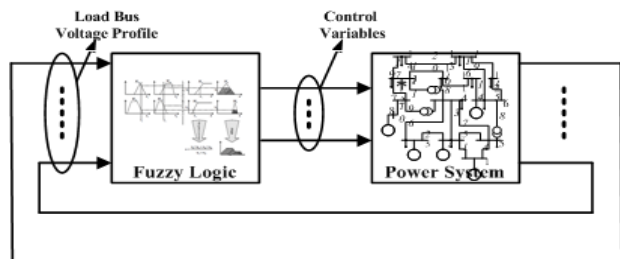

Fig. 1 Simultaneous voltage control of a power system

III. FUZZY LOGIC

Fuzzy sets are the basic concept of fuzzy logic. A fuzzy set is an extension of a crisp set which allows only full membership or non-membership whereas fuzzy sets allow partial membership. In a crisp set, the boundaries are precise. For example consider a classical set A :

$$A = \{x / x \geq 0, x \in \mathbb{N}\}$$

$$\begin{aligned} \text{if } x \geq 0 \quad x \in A &\leftrightarrow \mu_A(x) = 1 \\ \text{if } x < 0 \quad x \notin A &\leftrightarrow \mu_A(x) = 0 \end{aligned} \quad (10)$$

Fuzzy sets represent commonsense linguistic labels like *slow, fast, small, large, heavy, low, medium*, etc. Thus, in fuzzy set, the boundaries are not precise $0 \leq \mu_A(x) \leq 1$.

Where $\mu_A(x)$ is defined as membership function. In general, a membership function is a curve that defines how each point in the input space is related to a membership value or degree of membership between 0 and 1.

Three popular membership functions Triangular, Trapezoidal, and Gaussian are shown in (11), (12), and (13), respectively.

$$\mu_A(x) = \begin{cases} 0, & x \leq a \text{ and } x \geq c \\ \frac{x-a}{b-a}, & a \leq x \leq b \end{cases} \quad (11)$$

$$\mu_A(x) = \begin{cases} 0, & x \leq a \\ \frac{x-a}{b-a}, & a \leq x \leq b \\ 1, & b \leq x \leq c \\ \frac{d-x}{d-c}, & c \leq x \leq d \\ 1, & x \geq d \end{cases} \quad (12)$$

$$\mu_A(x) = \exp\left(-\frac{1}{2}\left(\frac{x-\bar{x}}{\sigma}\right)^2\right). \quad (13)$$

Fuzzy Inference Systems (FISs) consist of if-then rules that specify a relationship between the input and output fuzzy sets. Fuzzy relations present a degree of presence or absence of association or interaction between the elements of two or more sets.

If x is A , then y is B ; This rule has a membership function $0 \leq \mu_R(x) \leq 1$. For most applications, the fuzzy membership function $\mu_R(x)$ for a given relation is obtained with minimum or product implication represented as,

$$\begin{aligned} \mu_{A \cap B}(x) &= \min[\mu_A(x), \mu_B(x)] \\ &= \mu_A(x) \mu_B(x). \end{aligned} \quad (14)$$

An FIS consists on mapping the input data vector into a scalar output using fuzzy rules, Fig. 2.

The mapping process involves input/output membership functions, fuzzy logic operators, if-then rules, aggregation of output sets, and defuzzification.

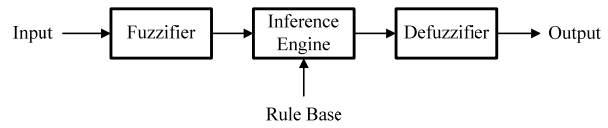

Fig. 2 Block diagram of fuzzy inference system

The Fuzzifier: maps input numbers into corresponding fuzzy memberships. This is required in order to activate rules that are in terms of linguistic variables. The Fuzzifier takes input values and determines the degree to which they belong to each of fuzzy sets via membership functions.

Inference Engine: defines mapping from input fuzzy sets into output fuzzy sets.

Aggregation: It is possible that one or more rules may fire at the same time. Outputs for all rules are then aggregated. During aggregation, the output set of each rule are combined into a single a single fuzzy set.

The Defuzzifier: maps output fuzzy sets into numbers. Given a fuzzy set that encompasses a range of output values, the defuzzifier returns one number, thereby moving from a fuzzy set to a crisp number. There are several methods for defuzzification; center of gravity, weighted average and center of areas.

Fuzzy rules play a key role in representing expert control/Modeling knowledge and experience linking the input variables of fuzzy controllers to output variable(s). There are two major types of fuzzy rules; Mamdani and Takagi-Sugeno.

A. Fuzzy c-Mean Clustering (FCMC)

Fuzzy c -means is a method of clustering which allows one piece of data to belong to two or more clusters [16]. A cluster is a set where its members are similar (in some sense). Every cluster has a center, v , and the membership function value of each data, x , depends on its distance from the center. For example,

$$\begin{aligned} \text{If } d(x, v_1) < d(x, v_2) \\ \text{than } \mu_{A_1}(x) > \mu_{A_2}(x). \end{aligned} \quad (15)$$

In general, if there are n data $\mathbf{x} = [x_1 \ x_2 \ \dots \ x_n]$ and c clusters with centers $\mathbf{v} = [v_1 \ v_2 \ \dots \ v_c]$. FCMC is to minimize the objective function,

$$J_m(\mathbf{U}, \mathbf{v}) = \sum_{k=1}^n \sum_{i=1}^c \mu_{ik}^m(x_k) \|x_k - v_i\|^2 \quad (16)$$

where $1 \leq m < \infty$ is a weighting exponent, $\mathbf{U} = [\mu_{ik}] \in \mathbb{R}^{c \times n}$ is the fuzzy matrix representation of the partition $\{x_k\}$. μ_{ik} is the membership of the data x_k in the cluster i and is computed as follows,

$$\mu_{ik}(x_k) = \left[\sum_{j=1}^c \left(\frac{\|x_k - v_i\|}{\|x_k - v_j\|} \right)^{\frac{2}{m-1}} \right]^{-1}; 1 \leq k \leq n; 1 \leq i \leq c. \tag{17}$$

The k^{th} center is found as,

$$v_i = \frac{\sum_{k=1}^n \mu_{ik}^m(x_k) x_k}{\sum_{k=1}^n \mu_{ik}^m}, 1 \leq i \leq c. \tag{18}$$

The FCMC algorithm can be summarized in Fig. 3.

IV. SIMULATION

A. Test Power System

To illustrate the effectiveness of the proposed FCMC technique for voltage control, the IEEE 14-bus power system, shown in Fig. 4., is considered. The control devices are five generators at buses 1, 2, 3, 6, and 8; one capacitive bank at bus 9; three Under Load Tap Changing (ULTC) transformers between buses 5 and 6 (line 8), 4 and 7 (line 9), and 4 and 11 (line 11). Thus, the total number of compensators which constitutes the number of the FCMC output is 9. The total number of inputs to the FCMC is 9 which constitute the load buses.

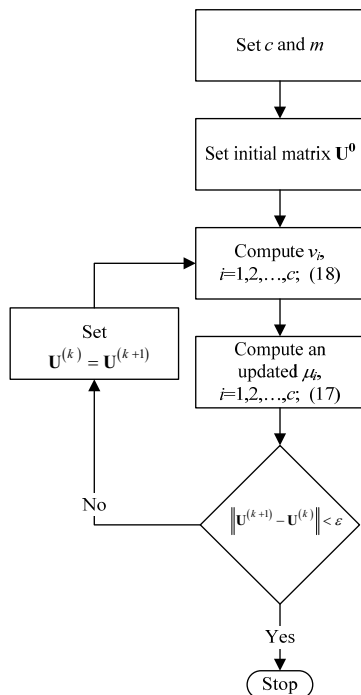

Fig. 3 FCMC algorithm

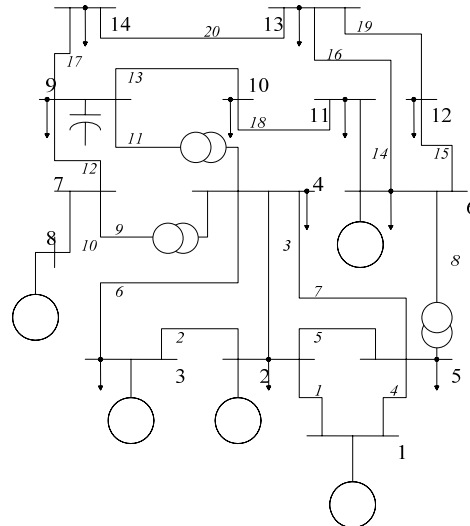

Fig. 4 The IEEE 14-Bus Power System

B. Data Set Selection

Should a contingency occurs, either an experienced dispatcher or an AI expert system would recommend the type and location of the controllers; and the amount of switching of the selected controllers. For a given set of combination of controllers and their settings, the voltage profile is found by running the power flow algorithm. Thus, to generate inputs and outputs data (simply a data set), it is required to go through several contingencies (cases) and tries to find their remedial solutions (targets). However, this way is time consuming, especially for large power systems, and it is not comprehensive.

Instead, we propose to work “backward;” the controllers will be switched randomly from their minimum to their maximum values with changeable incremental values. And, for each set of controllers, the voltage profile is calculated. The data set, which includes 100,028 runs or cases and targets, will be used to train and validate the FCMC.

Now to validate the FCMC, 100 new contingencies were designed and applied to the trained FCMC. Out of the 100 contingencies, the FCMC gave 87 correct solutions, i.e., the voltage profile being within the allowable limits of $1 \pm 5\%$.

To test the effectiveness of the FCMC technique, a new contingency was fabricated; a 100 MW, 50 MVAR load was added to bus 7. Initially, the IEEE 14-bus power system was operating normally at steady-state where the voltage profile is within the allowable limits of $1 \pm 5\%$, the dashed-dotted line shown in Fig. 5. This contingency causes the voltages at buses 4, 7, 9, 10, and 14 to be outside the allowable limits, the dotted line shown in Fig. 5. When the new contingency is presented to the trained FCMC, an instant solution is deduced, the solid line shown in Fig. 5.

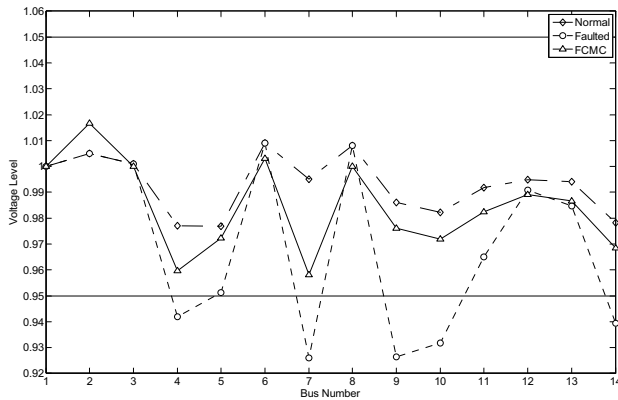

Fig. 5 The Normal (dashed-dotted line), the faulted (dotted line), and the FCMC corrected (solid line) voltage profiles

The recommended settings of the controllers (i.e., locations and amounts of switching of controllers) for this remedial action are shown in Table I.

Normally, the generating units are spared until the last resort. Thus, the FCMC is retained with four controllers namely the capacitor bank and the three ULTC transformers. To validate the newly trained FCMC, the 100 contingencies were applied to the trained FCMC. Out of the 100 contingencies, the FCMC gave 44 correct solutions.

TABLE I
THE TRAINED FCMC RECOMMENDED SETTINGS OF THE CONTROLLERS – THE CASE OF FIG. 5

| Type | Location | Action | Amount |
|-----------|----------|-----------|---------|
| Generator | Bus 1 | No Change | – |
| Generator | Bus 2 | Increase | 1.18 % |
| Generator | Bus 3 | Decrease | 0.10 % |
| Generator | Bus 6 | Decrease | 0.59 % |
| Generator | Bus 8 | Decrease | 0.80 % |
| Capacitor | Bus 9 | Increase | 44.00 % |
| ULTC | Line 8 | Increase | 7.83 % |
| ULTC | Line 9 | Decrease | 2.61 % |
| ULTC | Line 11 | Increase | 3.10 % |

To test the effectiveness of the newly trained FCMC without the generators, a new contingency was fabricated. This contingency causes the voltages at buses 4 and 5 to be below the limit and 7, and 9 to be above the limit, the dotted line shown in Fig. 6. When the new contingency is presented to the newly trained FCMC, an instant solution is deduced, the solid line of Fig. 6.

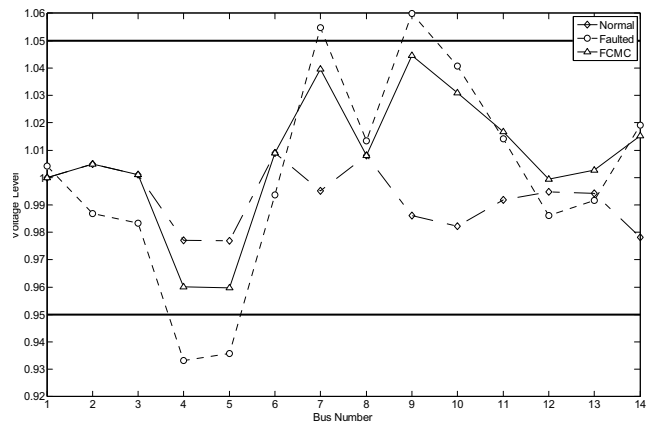

Fig. 6 The Normal (dashed-dotted line), the faulted (dotted line), and the FCMC corrected (solid line) voltage profiles

The recommended settings of the controllers for this remedial action are shown in Table II.

TABLE II
THE TRAINED FCMC RECOMMENDED SETTINGS OF THE CONTROLLERS – THE CASE OF FIG. 6.

| Type | Location | Action | Amount |
|-----------|----------|----------|--------|
| Capacitor | Bus 9 | Increase | 0.37 % |
| ULTC | Line 8 | Increase | 0.89 % |
| ULTC | Line 9 | Increase | 0.89 % |
| ULTC | Line 11 | Increase | 0.88 % |

V. CONCLUSION

The paper presented a Fuzzy C-Mean Clustering (FCMC) algorithm to be used in the steady-state voltage stability of a power system. The FCMC is trained so that it instantly maps a solution (i.e., locations and amounts of switching of controllers) to a contingent IEEE 14-bus power system. The results were acceptable when all the controllers are used. Approximately 87 % correct solutions, i.e., the voltage profile being within the allowable limits of 1 ± 5 %, are achieved. However, when the generators are spared, the results deteriorated to 44 %. Trained Neural Networks were shown to be more effective in finding solutions to the static voltage control problem [11].

REFERENCES

- [1] M. R. Khaldi, A. K. Sarkar, K. Y. Lee, and Y. M. Park, "The Modal Performance Measure for Parameter optimization of Power System Stabilizer." IEEE Transactions on Energy Conversion, vol. 8, no. 4, pp. 660-666, December 1993.
- [2] K. R. C. Mamandur, "Emergency Adjustments to VAR Control Variables to Alleviate Over-Voltages, Under-Voltages and Generated VAR limit violations," IEEE Transactions on Power Apparatus and Systems, vol. PAS-101, no. 5, May 1982, pp 1040-1047.
- [3] J. Zaborszky, G. Huang, and K. W. Lu, "A Textured Model for Computationally Efficient Reactive Power Control and Management," IEEE Transactions on Power Apparatus and Systems, vol. PAS-104, July 1985, pp. 1718-1727.
- [4] K. Iba, H. Suzuki, K. I. Suzuki, and K. Suzuki, "Practical Reactive Power Allocation/Operational Planning Using Successive Linear Programming," IEEE/PES Winter Meeting 1987, paper no. 055-7.

- [5] K. Tomsovic, and D. M. Faleo, "Advanced power system controls using intelligent systems," IEEE Power Engineering Society Summer Meeting 2000, vol. 1, pp. 336 – 33.
- [6] M. R. Khaldi, "An Intelligent Cognitive Expert System for Voltage Control in Power Systems," Proceedings of 2003 IEEE Conference on Control Applications (CCA 2003), vol. 1, pp. 319-24, June 2003.
- [7] C. C. Liu and K. Tomsovic, "An Expert System Assisting Decision-Making of Reactive Power/Voltage Control," IEEE Transactions on Power Systems, vol. 1, no. 3, August 1986, pp. 195-201.
- [8] M. Aggoune, M. A. El-Sharkawi, D. C. Park, M. J. Damborg, and R. J. Marks II, "Preliminary Results on Using Artificial Neural Networks for Security Assessment," Proceedings of the IEEE Conference on Decision and Control, 1989, pp. 252-258.
- [9] K. C. Hui, and M. J. Short, "Voltage Security Monitoring, Prediction and Control by Neural Networks," IEE International Conference on Advances in Power System Control, Operation and Management, November 1991, pp. 889-894.
- [10] K. Y. Lee, Y. T. Cha, and J. H. Park, "Short-Term Load Forecasting Using Artificial Neural Network," IEEE Transactions on Power Systems, vol. 7, pp. 1-8, February 1992.
- [11] M. R. Khaldi, "Neural Networks and Static Voltage Stability in Power Systems," IEEE International Conference on Industrial Technology (IEEE ICIT2008), April 21-24, 2008, Sichuan University, Chengdu, China, Paper ID: ZD-007498.
- [12] S. Senthil Kumar and P. Ajay-D-Vimal Raj, "Fuzzy Logic Based Stability Index Power System Voltage Stability Enhancement," International Journal of Computer and Electrical Engineering, Vol. 2, No. 1, February, 2010 1793-8163.
- [13] A. Narendranath Udupa, D. Thukaram and K. Parthasarathy, "An Expert Fuzzy Control Approach To Voltage Stability Enhancement," International Journal Of Electrical Power And Energy Systems, vol.21, 1999, pp 279-287.
- [14] Su C-T, Lin C-T, "Fuzzy Based Voltage/Reactive Power Scheduling For Voltage Security Improvement And Loss Reduction," IEEE Transaction on Power Delivery, vol. 16, no. 2, April. 2001, pp 319-323.
- [15] B. Marques and N. Toranto, "A Knowledge- Based System for Supervision and Control of Regional Voltage Profile and Security," IEEE Transaction on Power Systems, vol. 20, no. 4, February 2005, pp. 400-407.
- [16] J. C. Bezdek, R. Ehrlich, and W. Full, "FCM: The Fuzzy c-Means Clustering Algorithm," Computers and Geosciences, vol. 10, no. 2-3, 1984, pp. 191-203.
- [17] S. N. Sivanandam, S. Sumathi, and S. N. Deepa, "Introduction to Fuzzy Logic using MATLAB," Springer-Verlag Berlin Heidelberg, New York, 2007.