

# Volume Fraction Law for Stainless Steel on Inner Surface and Nickel on Outer Surface For FGM Cylindrical Shell

M.Hosseinjani Zamenjani<sup>1,\*</sup>, A.R.Tahmasebi Birgani<sup>2</sup>, M.R.Isvandzibaei<sup>3</sup>

**Abstract**—Vibration of thin cylindrical shells made of a functionally graded material composed of stainless steel and nickel is presented. The effects of the FGM configuration are studied by studying the frequencies of FG cylindrical shells. In this case FG cylindrical shell has Nickel on its outer surface and stainless steel on its inner surface. The study is carried out based on third order shear deformation shell theory. The objective is to study the natural frequencies, the influence of constituent volume fractions and the effects of configurations of the constituent materials on the frequencies. The properties are graded in the thickness direction according to the volume fraction power-law distribution. Results are presented on the frequency characteristics, the influence of the constituent various volume fractions on the frequencies.

**Keywords**—Nickel, Stainless Steel, Cylindrical shell.

## I. INTRODUCTION

STAINLESS STEEL are often used as load bearing structures for aircrafts, ships and buildings. Understanding of vibration behavior of cylindrical shells is an important aspect for the successful applications of cylindrical shells. Researches on free vibrations of cylindrical shells have been carried out extensively [1-5]. Recently, the present authors presented studies on the influence of boundary conditions on the frequencies of a multi-layered cylindrical shell [6]. In all the above works, different thin shell theories based on Love-hypothesis were used. Vibration of cylindrical shells with ring support is considered by Loy and Lam [7]. The concept of functionally graded materials (FGMs) was first introduced in 1984 by a group of materials scientists in Japan [8-9] as a means of preparing thermal barrier materials. Since then, FGMs have attracted much interest as heat-shielding

materials. FGMs are made by combining different materials using power metallurgy methods [10]. Vibration study of FG cylindrical shell structures is important. This cylindrical shell considered are composed of stainless steel and nickel where the volume fractions follow a power-law distribution.

## II. FUNCTIONALLY GRADED MATERIALS

For the cylindrical shell made of FGM the material properties such as the modulus of elasticity  $E$ , Poisson ratio  $\nu$  and the mass density  $\rho$  are assumed to be functions of the volume fraction of the constituent materials when the coordinate axis across the shell thickness is denoted by  $z$  and measured from the shell's middle plane. The functional relationships between  $E$ ,  $\nu$  and  $\rho$  with  $z$  for a stainless steel and nickel FGM shell are assumed as:

$$E = (E_1 - E_2) \left( \frac{2Z + h}{2h} \right)^N + E_2 \quad (1)$$

$$\nu = (\nu_1 - \nu_2) \left( \frac{2Z + h}{2h} \right)^N + \nu_2 \quad (2)$$

$$\rho = (\rho_1 - \rho_2) \left( \frac{2Z + h}{2h} \right)^N + \rho_2 \quad (3)$$

The third- order theory of Reddy used in the present study is based on the following displacement field:

$$\begin{cases} U_1 = u_1(\alpha_1, \alpha_2) + \alpha_3 \phi_1(\alpha_1, \alpha_2) + \alpha_3^2 \psi_1(\alpha_1, \alpha_2) + \alpha_3^3 \beta_1(\alpha_1, \alpha_2) \\ U_2 = u_2(\alpha_1, \alpha_2) + \alpha_3 \phi_2(\alpha_1, \alpha_2) + \alpha_3^2 \psi_2(\alpha_1, \alpha_2) + \alpha_3^3 \beta_2(\alpha_1, \alpha_2) \\ U_3 = u_3(\alpha_1, \alpha_2) \end{cases} \quad (4)$$

These equations can be reduced by satisfying the stress-free conditions on the top and bottom faces of the laminates, which are equivalent to  $\epsilon_{13} = \epsilon_{23} = 0$  at  $Z = \pm \frac{h}{2}$ . Thus

$$\begin{cases} U_1 = u_1(\alpha_1, \alpha_2) + \alpha_3 \phi_1(\alpha_1, \alpha_2) - C_1 \alpha_3^3 \left( -\frac{u_1}{R_1} + \phi_1 + \frac{\partial u_3}{A_1 \partial \alpha_1} \right) \\ U_2 = u_2(\alpha_1, \alpha_2) + \alpha_3 \phi_2(\alpha_1, \alpha_2) - C_1 \alpha_3^3 \left( -\frac{u_2}{R_2} + \phi_2 + \frac{\partial u_3}{A_2 \partial \alpha_2} \right) \\ U_3 = u_3(\alpha_1, \alpha_2) \end{cases}$$

<sup>1,\*</sup> M.Hosseinjani Zamenjani, Islamic Azad University, Shoushtar Branch, Department of Engineering, Shoushtar, Iran. Corresponding author, E-mail address: hosseinjani822@yahoo.com.

<sup>2</sup> A.R.Tahmasebi Birgani, Islamic Azad University, Shoushtar Branch, Department of Engineering, Shoushtar, Iran.

<sup>3</sup> M.R.Isvandzibaei, Islamic Azad University, Andimeshk Branch, Andimeshk, Iran.

III. FORMULATION

Consider a cylindrical shell is shown in Fig.1.  $R$  is the radius,  $L$  is the length and  $h$  is the thickness. The reference surface is chosen to be the middle surface of the cylindrical shell where an orthogonal coordinate system  $x, \theta, z$  is fixed. The deformations of the shell with reference to this coordinate system are denoted by  $U_1, U_2$  and  $U_3$  in the  $x, \theta$  and  $z$  directions, respectively.

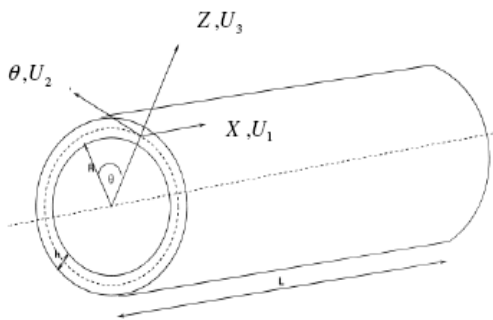

Fig. 1 Geometry of a cylindrical shell

For a thin cylindrical shell, plane stress condition can be assumed. The constitutive relation for a thin cylindrical shell is consequently given by the two-dimensional Hook's law as

$$\{\sigma\} = [Q] \{\varepsilon\} \tag{6}$$

where,  $\{\sigma\}$  is the stress vector,  $\{\varepsilon\}$  is the strain vector and  $[Q]$  is the reduced stiffness matrix. The stress vector for plane stress condition is

$$\{\sigma\}^T = \{\sigma_{11} \ \sigma_{22} \ \sigma_{12} \ \sigma_{13} \ \sigma_{23}\} \tag{7}$$

where  $\sigma_{11}$  is the stress in  $x$  direction,  $\sigma_{22}$  the stress in the  $\theta$  direction and  $\sigma_{12}$  is the shear stress on the  $x\theta$  plane and  $\sigma_{13}$  is the shear stress on the  $xz$  plane and  $\sigma_{23}$  is the shear stress on the  $\theta z$  plane. The strain vector is defined as

$$\{\varepsilon\}^T = \{\varepsilon_{11} \ \varepsilon_{22} \ \varepsilon_{12} \ \varepsilon_{13} \ \varepsilon_{23}\} \tag{8}$$

where  $\varepsilon_{11}$  is the strain in  $x$  direction,  $\varepsilon_{22}$  the strain in the  $\theta$  direction and  $\varepsilon_{12}$  is the shear strain on the  $x\theta$  plane and  $\varepsilon_{13}$  is the shear strain on the  $xz$  plane and  $\varepsilon_{23}$  is the shear strain on the  $\theta z$  plane. The reduced stiffness  $[Q]$  matrix is given as

$$[Q] = \begin{bmatrix} Q_{11} & Q_{12} & 0 & 0 & 0 \\ Q_{12} & Q_{22} & 0 & 0 & 0 \\ 0 & 0 & Q_{44} & 0 & 0 \\ 0 & 0 & 0 & Q_{55} & 0 \\ 0 & 0 & 0 & 0 & Q_{66} \end{bmatrix} \tag{9}$$

For an isotropic cylindrical shell the reduced stiffness  $Q_{ij}$  ( $i, j=1, 2$  and  $6$ ) are defined as

$$Q_{11} = Q_{22} = \frac{E}{1-\nu^2} \tag{10}$$

$$Q_{12} = \frac{\nu E}{1-\nu^2} \tag{11}$$

$$Q_{44} = Q_{55} = Q_{66} = \frac{E}{2(1+\nu)} \tag{12}$$

where  $E$  is the Young's modulus and  $\nu$  is Poisson's ratio. For a thin cylindrical shell the force and moment results are defined as

$$\begin{Bmatrix} N_{11} \\ N_{22} \\ N_{12} \end{Bmatrix} = \int_{-\frac{h}{2}}^{\frac{h}{2}} \begin{Bmatrix} \sigma_{11} \\ \sigma_{22} \\ \sigma_{12} \end{Bmatrix} d\alpha_3, \quad \begin{Bmatrix} M_{11} \\ M_{22} \\ M_{12} \end{Bmatrix} = \int_{-\frac{h}{2}}^{\frac{h}{2}} \begin{Bmatrix} \sigma_{11} \\ \sigma_{22} \\ \sigma_{12} \end{Bmatrix} \alpha_3^2 d\alpha_3 \tag{13}$$

$$\begin{Bmatrix} P_{11} \\ P_{22} \\ P_{12} \end{Bmatrix} = \int_{-\frac{h}{2}}^{\frac{h}{2}} \begin{Bmatrix} \sigma_{11} \\ \sigma_{22} \\ \sigma_{12} \end{Bmatrix} \alpha_3^3 d\alpha_3, \quad \begin{Bmatrix} P_{13} \\ P_{23} \end{Bmatrix} = \int_{-\frac{h}{2}}^{\frac{h}{2}} \begin{Bmatrix} \sigma_{13} \\ \sigma_{23} \end{Bmatrix} \alpha_3^3 d\alpha_3 \tag{14}$$

$$\begin{Bmatrix} Q_3 \\ Q_{23} \end{Bmatrix} = \int_{-\frac{h}{2}}^{\frac{h}{2}} \begin{Bmatrix} \sigma_{13} \\ \sigma_{23} \end{Bmatrix} d\alpha_3, \quad \begin{Bmatrix} R_{13} \\ R_{23} \end{Bmatrix} = \int_{-\frac{h}{2}}^{\frac{h}{2}} \begin{Bmatrix} \sigma_{13} \\ \sigma_{23} \end{Bmatrix} \alpha_3^2 d\alpha_3 \tag{15}$$

The constitutive equation is obtained as

$$\{N\} = [S] \{\varepsilon\} \tag{16}$$

where  $\{N\}$  and  $\{\varepsilon\}$  are, respectively, defined as

$$\{N\}^T = \{N_1 \ N_2 \ N_{12} \ M_1 \ M_2 \ M_{12} \ P_1 \ P_2 \ P_{12} \ P_3 \ P_{23} \ Q_3 \ Q_{23} \ R_{13} \ R_{23}\} \tag{17}$$

$$\{\varepsilon\}^T = \{\varepsilon_1^0 \ \varepsilon_2^0 \ \varepsilon_3^0 \ k_{11} \ k_{22} \ k_{12} \ k'_{11} \ k'_{22} \ k'_{12} \ \gamma_{23}^0 \ \gamma_{13}^0 \ \gamma_{23}^2 \ \gamma_{13}^2 \ \gamma_{23}^3 \ \gamma_{13}^3\} \tag{18}$$

and  $[S]$  is defined as

$$[S] = \begin{pmatrix} [A] & [B] & [E] \\ [B] & [D] & [F] \\ [E] & [F] & [H] \\ [E'] & [G] & [H'] \\ [A'] & [D'] & [E'] \\ [D'] & [F'] & [G'] \end{pmatrix} \quad (19)$$

where A, B, E, D, F, H and G are the extensional, coupling and bending stiffness matrices and  $Q_{ij}$  are functions of  $z$  for functionally gradient materials. Here  $A_{ij}$  denote the extensional stiffness,  $D_{ij}$  the bending stiffness,  $B_{ij}$  the bending-extensional coupling stiffness and  $E_{ij}, F_{ij}, G_{ij}, H_{ij}$  are the extensional, bending, coupling, and higher-order stiffness. Defining

$$\{A_{ij}, B_{ij}, D_{ij}, E_{ij}, F_{ij}, G_{ij}, H_{ij}\} = \int_{-h/2}^{h/2} Q_{ij} \{1, \alpha_3, \alpha_3^2, \alpha_3^3, \alpha_3^4, \alpha_3^5, \alpha_3^6\} dz \quad (20)$$

The strain energy and kinetic energy of a cylindrical shell can be defined as

$$U = \frac{1}{2} \iiint \{\varepsilon\}^T \{\sigma\} dV \quad (21)$$

$$T = \frac{1}{2} \iiint \rho \left[ \left( \frac{\partial u_1}{\partial t} \right)^2 + \left( \frac{\partial u_2}{\partial t} \right)^2 + \left( \frac{\partial u_3}{\partial t} \right)^2 + \left( \frac{\partial \phi_1}{\partial t} \right)^2 + \left( \frac{\partial \phi_2}{\partial t} \right)^2 \right] dV \quad (22)$$

where,  $\rho$  is the mass density,  $\{\varepsilon\}$  is the strain vector and  $\{\sigma\}$  is the stress vector. By substituting from Eq. (6), the strain and kinetic energies can be written as

$$U = \frac{1}{2} \int_0^L \int_0^{2\pi} \{\varepsilon\}^T [S] \{\varepsilon\} R d\theta dx \quad (23)$$

$$T = \frac{1}{2} \int_0^L \int_0^{2\pi} \rho R \left[ \left( \frac{\partial u_1}{\partial t} \right)^2 + \left( \frac{\partial u_2}{\partial t} \right)^2 + \left( \frac{\partial u_3}{\partial t} \right)^2 + \left( \frac{\partial \phi_1}{\partial t} \right)^2 + \left( \frac{\partial \phi_2}{\partial t} \right)^2 \right] R d\theta dx \quad (24)$$

The displacement fields for a cylindrical shell can be written as:

$$\begin{aligned} u_1 &= \bar{A} \frac{\partial \phi(x)}{\partial x} \cos(n\theta) \cos(\omega t) \\ u_2 &= \bar{B} \phi(x) \sin(n\theta) \cos(\omega t) \\ u_3 &= \bar{C} \phi(x) \cos(n\theta) \cos(\omega t) \\ \phi_1 &= \bar{D} \frac{\partial \phi(x)}{\partial x} \cos(n\theta) \cos(\omega t) \\ \phi_2 &= \bar{E} \phi(x) \sin(n\theta) \cos(\omega t) \end{aligned} \quad (25)$$

where,  $\bar{A}, \bar{B}, \bar{C}, \bar{D}$  and  $\bar{E}$  are the constants denoting the amplitudes of the vibrations in the  $x, \theta$  and  $z$  directions,  $\phi(x)$  is the axial function that satisfies the geometric boundary conditions,  $n$  denotes the number of circumferential waves in the mode shape and  $\omega$  is the natural angular frequency of the vibration. The axial function  $\phi(x)$  is chosen as the beam function as:

$$\phi(x) = \alpha_1 \cosh\left(\frac{\lambda_m x}{L}\right) + \alpha_2 \cos\left(\frac{\lambda_m x}{L}\right) - \zeta_m (\alpha_3 \sinh\left(\frac{\lambda_m x}{L}\right) + \alpha_4 \sin\left(\frac{\lambda_m x}{L}\right)) \quad (26)$$

where  $\alpha_i$  ( $i = 1, \dots, 4$ ) are some constants with value 0 or 1 chosen according to the boundary conditions.  $\lambda_m$ , are the roots of some transcendental equations and  $\zeta_m$  are some parameters dependent on  $\lambda_m$ . The energy functional  $\Pi$  defined by the Lagrangian function as

$$\Pi = T_{\max} - U_{\max} \quad (27)$$

With minimizing the energy functional  $\Pi$  with respect to the unknown coefficients as follows,

$$\frac{\partial \Pi}{\partial A} = \frac{\partial \Pi}{\partial B} = \frac{\partial \Pi}{\partial C} = \frac{\partial \Pi}{\partial D} = \frac{\partial \Pi}{\partial E} = 0 \quad (28)$$

$T_{\max}$  and  $U_{\max}$  are the maximum kinetic energy and strain energy, respectively. In Eq. (28), the five governing eigenvalue equations can be obtained. These five governing eigenvalue equation can be expressed in matrix from as

$$\begin{bmatrix} C_{11} & C_{12} & C_{13} & C_{14} & C_{15} \\ C_{21} & C_{22} & C_{23} & C_{24} & C_{25} \\ C_{31} & C_{32} & C_{33} & C_{34} & C_{35} \\ C_{41} & C_{42} & C_{43} & C_{44} & C_{45} \\ C_{51} & C_{52} & C_{53} & C_{54} & C_{55} \end{bmatrix} \begin{Bmatrix} \bar{A} \\ \bar{B} \\ \bar{C} \\ \bar{D} \\ \bar{E} \end{Bmatrix} = \begin{Bmatrix} 0 \\ 0 \\ 0 \\ 0 \\ 0 \end{Bmatrix} \quad (29)$$

The eigenvalue equations are solved by imposing the non-trivial solutions condition and equating the determinant of the characteristic matrix  $[C_{ij}]$  to zero. Expanding this determinant, a polynomial in even powers of  $\omega$  is obtained

$$\beta_5 \omega^{10} + \beta_4 \omega^8 + \beta_3 \omega^6 + \beta_2 \omega^4 + \beta_1 \omega^2 + \beta_0 = 0 \quad (30)$$

where  $\beta_i$  ( $i = 0, 1, 2, 3, 4, 5$ ) are some constants. Eq. (30) is solved five positive and five negative roots are obtained. The five positive roots obtained are the natural angular frequencies of the cylindrical shell in the  $x, \theta$  and  $z$  directions. The smallest of the five roots is the natural angular frequency studied in the present study.

## VI. RESULTS AND DISCUSSION

The functionally gradient material (FGM) considered is composed of stainless steel and nickel and its properties are graded in the thickness direction according to the volume fraction power-law distribution. The influence of constituent volume fractions is studied by varying the volume fractions of the stainless steel and nickel. This is carried out by varying the value of the power law exponent  $N$ . The effects of the FGM configuration are studied by studying the frequencies of FG cylindrical shells. Type FG cylindrical shell has Nickel on its inner surface and stainless steel on its outer surface. The material properties for stainless steel and nickel, calculated at  $T = 300K$ , are presented. In this section variations of natural frequencies with the circumferential wave number  $n$  for functional graded cylindrical shells with different volume fractions are presented. Tables 1 and 2 show variations of natural frequencies for FG cylindrical shell. The influence of the constituent volume fraction on the frequencies for FG cylindrical shells has been found to be different. For the FG cylindrical shells, the natural frequencies decreased when  $N$  increased. the natural frequencies for all values of  $N$  lie between those for a stainless steel and Nickel cylindrical shells. For  $N < 1$ , the natural frequencies for FG cylindrical shells are higher.

TABLE I  
VARIATIONS OF NATURAL FREQUENCIES WITH THE CIRCUMFERENTIAL  
WAVE NUMBER N FOR FG CYLINDRICAL SHELL  
M=1, H/R=0.002, L/R=20

n	f(Hz)					
	N=0.5	N=0.7	N=1	N=2	N=5	N=15
1	13.319	13.267	13.209	13.101	12.996	12.930
2	4.514	4.496	4.476	4.440	4.4046	4.382
3	4.190	4.173	4.156	4.123	4.0914	4.070
4	7.101	7.074	7.044	6.989	6.9357	6.899
5	11.345	11.301	11.254	11.166	11.080	11.022
6	16.609	16.545	16.475	16.348	16.222	16.1374
7	22.848	22.760	22.664	22.489	22.315	22.199
8	29.052	29.937	29.811	29.580	29.351	29.198
9	38.219	38.072	37.912	37.618	37.328	37.133
10	47.347	47.166	46.967	46.604	46.244	46.002

TABLE II  
VARIATIONS OF NATURAL FREQUENCIES WITH THE CIRCUMFERENTIAL  
WAVE NUMBER N FOR FG CYLINDRICAL SHELL  
M=1, H/R=0.002, L/R=20

n	f(Hz)					
	N=0.5	N=0.7	N=1	N=2	N=5	N=15
1	13.321	13.269	13.211	13.103	12.997	12.932
2	32.679	32.553	32.416	32.165	31.917	31.751
3	91.388	91.037	90.652	89.951	89.258	88.795
4	174.998	174.326	173.590	172.246	170.920	170.035
5	282.855	281.769	280.578	278.407	276.263	274.832
6	414.818	413.225	411.480	408.295	405.151	403.053
7	570.840	568.648	566.246	561.863	557.537	554.650
8	750.900	748.016	750.853	739.091	733.400	729.603
9	954.987	951.319	947.300	939.968	932.731	927.902
10	1183.096	1178.552	1173.573	1164.489	1155.52	1149.542

## REFERENCES

- [1] Arnold, R.N., Warburton, G.B., 1948. Flexural vibrations of the walls of thin cylindrical shells. Proceedings of the Royal Society of London A; 197:238-256.
- [2] Ludwig, A., Krieg, R., 1981. An analysis quasi-exact method for calculating eigen vibrations of thin circular shells. J. Sound vibration; 74,155-174.
- [3] Chung, H., 1981. Free vibration analysis of circular cylindrical shells. J. Sound vibration; 74, 331-359.
- [4] Soedel, W., 1980. A new frequency formula for closed circular cylindrical shells for a large variety of boundary conditions. J. Sound vibration; 70,309-317.
- [5] Forsberg, K., 1964. Influence of boundary conditions on modal characteristics of cylindrical shells. AIAA J; 2, 182- 189.
- [6] Lam, K.L., Loy, C.T., 1995. Effects of boundary conditions on frequencies characteristics for a multi-layered cylindrical shell. J. Sound vibration; 188, 363-384.
- [7] Loy, C.T., Lam, K.Y., 1996. Vibration of cylindrical shells with ring support. I. Journal of Impact Engineering; 1996; 35:455.
- [8] Koizumi, M., 1993. The concept of FGM Ceramic Transactions, Functionally Gradient Materials.
- [9] Makino A, Araki N, Kitajima H, Ohashi K. Transient temperature response of functionally gradient material subjected to partial, stepwise heating. Transactions of the Japan Society of Mechanical Engineers, Part B 1994; 60:4200-6(1994).
- [10] Anon, 1996. FGM components: PM meets the challenge. Metal powder Report. 51:28-32.