

Power System Contingency Analysis Using Multiagent Systems

Anant Oonsivilai and Kenedy A. Greyson

Abstract—The demand of the energy management systems (EMS) set forth by modern power systems requires fast energy management systems. Contingency analysis is among the functions in EMS which is time consuming. In order to handle this limitation, this paper introduces agent based technology in the contingency analysis. The main function of agents is to speed up the performance. Negotiations process in decision making is explained and the issue set forth is the minimization of the operating costs. The IEEE 14 bus system and its line outage have been used in the research and simulation results are presented.

Keywords—Agents, model, negotiation, optimal dispatch, power systems.

I. INTRODUCTION

MODERN techniques in computer, communication and electric power systems provides a way forward to give new possibilities for energy management systems. The ongoing deregulation and restructuring in power system worldwide require more complex control and decision making [1]. Power system decision problems fall under operations, maintenance, or planning category. Some of these decision problems include: transmission upgrades, fuel scheduling, preventive and corrective actions, incident restoration, transmission service scheduling, unit commitment, transmission equipment maintenance, generation dispatching, etc.

For consistent service, power system must remain intact and be able to endure a wide variety of disturbances. It should operate in normal and secured condition. Therefore, it is important that the system to be designed and operated so that the more possible contingencies can be sustained with no loss of load. Operating conditions of power system can be determined if the network model and complex phasor voltages at every system bus is known [2]. If all the loads in the system can be supplied power without violation of any operational constrains, then the system is in normal state. Examples of these operational constrains include the limits on the

transmission line flow, as well as upper and lower (i.e. limits) on bus voltage magnitudes [2].

Distribution generations, scattered throughout a power system, provide the electric power needed by electrical customers. Economy, reliability, and security functions of a power system are very essential functions in EMS. In this research individual interest of economy based on power dispatching of generating units is considered. The fast decision demand for balancing the generating units and/or modification of network topology considered.

It is based on detection of any violation in the system and to ensure optimum power dispatch of the system in deregulated environment. Power systems are extremely complex and highly interactive. In order to monitor, assess and control large-scale electric power system, operators depend on an array of measured quantities obtained from the state estimators.

Negotiations model proposed is based on intelligent agents with degree of knowledge of the facts about the system. Artificial Intelligence (AI) is composed with the center of attention on creating module that can employ on behaviors that humans consider intelligent. It has provided techniques for encoding and reasoning with declarative knowledge. It has been identified as a future of computation in many publications. Incidentally, most uncertain and unexpected problems require a certain degree of intelligence to be solved. In fact, for a computer to solve a certain problem, it must know *enough* facts about the problem. In this context, enough refers to the minimum information required by the problem.

Emergence of artificial intelligence (AI) and cognitive sciences concerned with understanding and modeling intelligent systems, both natural and synthetic [6] and [12]. Several applications of AI in power systems have been published. In [7] a technique of self-organizing using fuzzy is applied in power system stabilizer. A dynamic model of power system using adaptive-network-based fuzzy inference system is presented in [8]. Another technique of wavelet neural network is used in power system operations as shown in [9]. In this research, the generator units balancing during contingencies are analyzed.

II. MULTIAGENT BASED SYSTEM

Agents are active object that are used to model parts of the real world system. They may be employed to represent separate processes which operate independently and interact with each other by exchanging the pertinent information [3].

A. Oonsivilai is with Alternative and Sustainable Energy Research Unit (ASER-U), Power and Control Research Group, School of Electrical Engineering, Institute of Engineering, Suranaree University of Technology, 111 University Street, Muang District, Nakhon Ratchasima, 30000, THAILAND (e-mail: anant@sut.ac.th).

K. A. Greyson with the School of Electrical Engineering, Institute of Engineering, Suranaree University of Technology, 111 University Street, Muang District, Nakhon Ratchasima, 30000, Thailand (e-mail: kenedyaliila@yahoo.com).

The systems that contain a group of agents that may interact with one another are called multiagent systems [4]. For the distributed approach, it is proposed that, when using the multiagent approach the power system network may be decomposed by dividing the system into subsystems with respect to voltage levels [5].

In principle, agents act autonomously on the base of collected information. Group of agents known as multiagent, with individual subtasks are coordinated so as to achieve a specific common goal. There are basically two configurations of agents: agents with different subtasks, and agents of the same kind and on the same hierarchical level [6]. In the first configuration, the autonomous component as agents request and provide information to other agents, while the second configuration needs particular methods such as negotiations to reach the global goals while keeping local constraints.

For a distributed generators to provide satisfactory service to its owner, depends on the objective evaluation of its capability and limitations, careful selection of when, where, and how it is used [10]. The act of agents is based on the objective assigned to it.

III. DETECTION OF POWER SYSTEM PROBLEMS

It should be noted that, line or generation outage may cause flow or voltages to fall outside limits. The contingency analyses (CA) are used to predict the effect of these outages. The state estimators' solutions are used to perform contingency analysis in power systems. Elements that contribute in power control system include: the accuracy in state estimation, and speed of CA algorithm. Therefore, the SE solution should be accurate and robust as possible for the better performance and the speed of computation is the expected results of agents based model where each agent is assigned a specific objective. In conventional methods of stability analysis by a time domain iterative process are too far slow for online operations. This poses a demand of the fast direct methods to analyze power system stability of electric power systems. Most contingency selection algorithm employs the second order performance indices which, suffers from masking (one huge violation) and misranking (i.e., the inaccuracies in the model used for computing the performance indices) effects.

IV. DESIGN OF AGENT

In order to achieve the main objective, each agent must develop an effective communication within the platform and globally and build working relationship as they negotiate towards the main objective which is the laid criterion. Therefore the design starts by setting plans and goals for each agent in the system where an agent is armed with coded negotiation model for the conflict resolution via inter exchange of messages.

In power system contingency assessment technique proposed here, each agent is assigned individual goal. However, in the point of decision, each goal (analogous to an issue) is prioritized. In the systems, agents may share the main

goal (objective). Negotiations between the agents are provoked based on observed changes in the system. The effective way of resolving the conflict (if any) caused by the change depends on how they understand the underlying dynamics of the conflicts. The next subsections give the method used for conflict management and negotiation contention used by agents. All sub objectives maintained by agents should be an integral part of optimal power flow function. Therefore, the agents will negotiate and compromise based on the security of the power system while optimizing cost of power production represented as $O = \{O_1, O_2, \dots, O_k\}$, where O is the main objective, and O_1, O_2, \dots, O_k are sub objectives.

Agent1: O_1 based on the power-flow

$$f_1(x, u) = 0$$

where f_1 is the power-flow function, x is the state variable (bus magnitude voltage and angle), and u is the control variable.

Agent2: O_2 based on the power flow

$$f_2(x, u) = 0$$

where f_2 is the operating constraints and limits on control variable.

Agent3: O_3 based on the cost of power production

$$f_3(x, u) = 0$$

where f_3 is the power capacity of the i^{th} bus/transmission line.

A. Conflict management

As mentioned earlier, for consistent service, power system must remain intact and be able to endure a wide variety of disturbances and it should operate in normal and secured condition. Fig. 1 shows the algorithm of the conflict analysis and management. Violation to this will create conflict. Note that, conflict is not interest of any agent; however in solving the conflict, each agent is biased by its interest.

Due to the fact that, the situation of difficult conflict based on the agents' objective models, the structure of agents should ranked to deal with the unions. These agents, which act as a group manager, intervene only when the conflict is difficult to be resolved because they are costly.

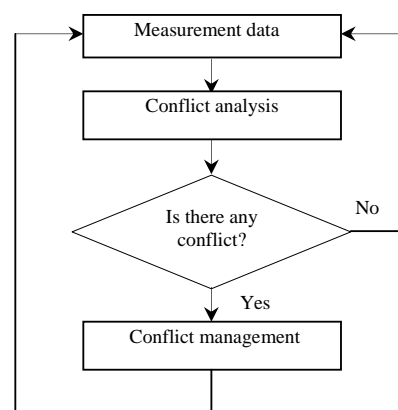

Fig. 1. Conflict analysis and management algorithm

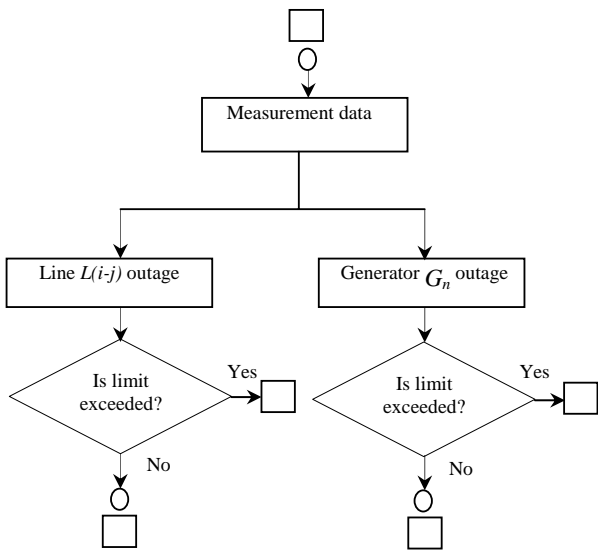

Fig. 2. Limits analysis framework

The conflict analysis is the process in which the system performance is analyzed and the output determines if there is any conflict or not. This process is shown in Fig. 2. Limits analysis framework presents the results of the contingency analysis for both line outage and generators outage based on the limits.

Bus voltage limit is among the results of the power system contingencies. If the limit is reached, the further analysis is considered. The level of the limit can be rectified by adjusting the generator units' outputs, power system topology adjustments, limiting load at certain buses, etc so as to accept the level of conflict as shown in Fig. 3. However, for the higher level of the conflict, that cannot rectify the problem. In this case, agents are involved to solve the problem by negotiation towards the optimum solution as shown by the negotiation framework presented in Fig. 4.

B. Contention of Agents

All agents are given equal right to contend towards the conflict resolution. The winner in the contention will depend on the level of ranking set by the particular agent. The rank of agents defined based on the cost involved and criteria set forth. Based on the interest set by all contenders, the rules and criteria are used to decide the winner which focuses on maximizing substantive outcomes in negotiations.

In order to exchange information between agents, there must be a communication channel between the agents. In this research, both communications via message and procedure call are considered. Negotiations and tactics involved are based on individual objectives and decision is taken back to the conflict level analysis. In the negotiation process as shown in Petri net Fig. 5, each agent is presenting its solution and choice is based on the best solution among the rest. The manager will issue a winning agent decision. The best choice is biased in the issues set as criteria for the decision.

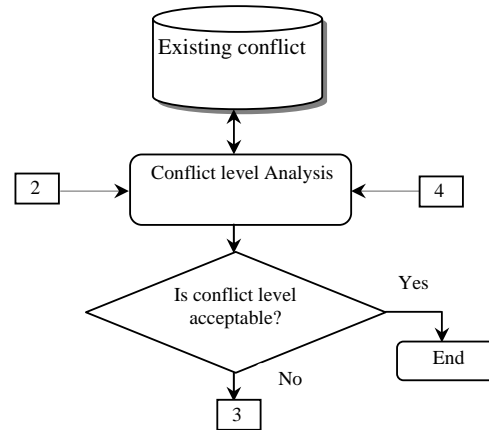

Fig. 3. Conflict level analysis.

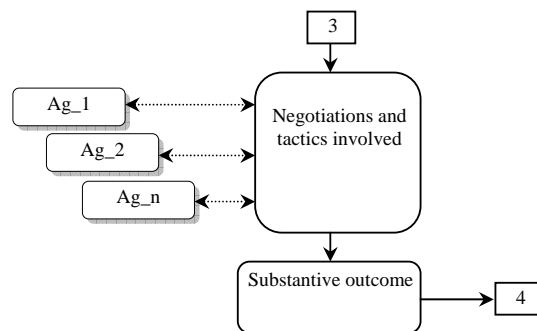

Fig. 4. Negotiation framework.

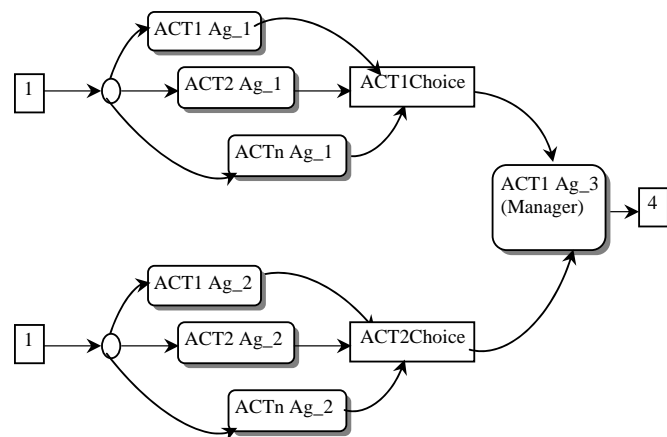

Fig. 5. Petri nets and scope boundaries.

V. AGENT NEGOTIATION THEORY

In the human environmental field of negotiation, the skilled negotiators should learn the negotiation base, i.e. individual interests, objectives, and options available on table. The key point is to achieve the best of the possibilities. Similarly,

agents in a system operate in the same manner, whereby agents (negotiators) are trained to know the system so that each will optimize its objective towards the success of the main objective. Unlike the human environment, in machine based negotiations both negotiators have individual objectives both all are aiming towards the same objective. In that case, there is no walk-away at the final court.

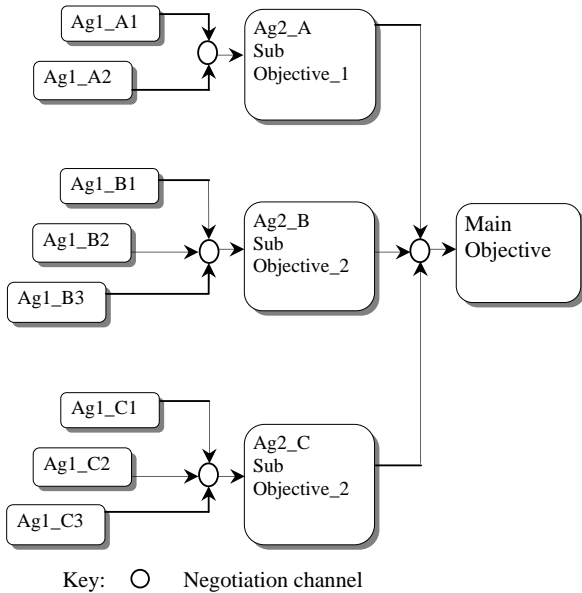

Fig. 6. Agents in a team structure

Depending on the scenario of the particular system, an agent can stand to achieve the objective or a team of agents can work together towards the same objective. In Fig 6, several agents work as a team to obtain a sub objective. The predefined sub objectives are designed in such a way that the main objective is achieved when sub objectives are achieved. This is referred to hierarchical designed agents.

VI. RESULTS AND DISCUSSION

The results and discussion are presented in this section. The assumption is based on the limited amount of power that can be sent over a transmission line (line capacity) and the failure can result in other lines overloading. Linear Factors is considered faster compared to the power flow.

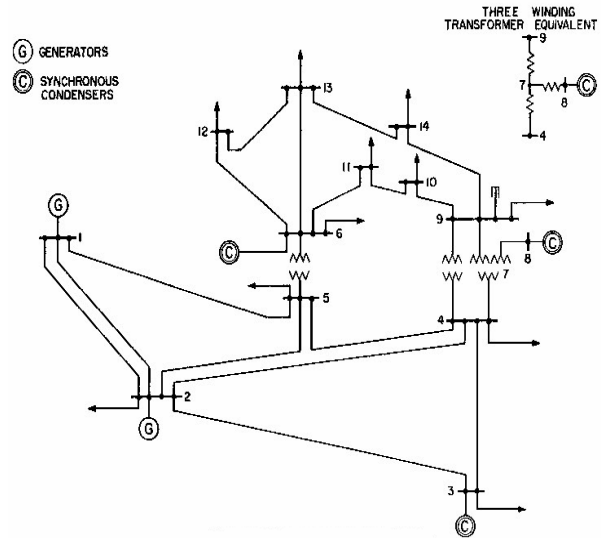

Fig. 7. IEEE 14-bus testing system.

In this simulation, the Line Outage Distribution Factors (LODF) that gives the current change in line is shown in Table II. LODF is used to show how the current flow on a line that is lost ends up on another lines. Therefore, the relationship is:

$$\text{Flow after outage} = \text{flow before outage} + (\text{LODF} * \text{flow on affected line before outage})$$

Fig. 7 is the IEEE 14-bus system used in the simulation and results are presented. Table I is the generation data used for the simulation. Table II presents the bus voltages from power-flow solution for selected line-outage cases. Table III presents the effect of the line outage and the computed optimal power dispatch. In the results it is observed that, in some cases, line outage has no significant change in either system power loss or generation cost.

TABLE I
IEEE 14 BUS SYSTEM GENERATION DATA

No.	Max. generated	Est. power generation unit parameters		
		α_i	β_i	γ_i
1	204	420	2.55	0.015
2	180	380	1.88	0.012
3	80	290	1.45	0.009
4	100	240	1.36	0.005

TABLE II
BUS VOLTAGE FROM POWER-FLOW SOLUTIONS OF THE IEEE 14 SYSTEM.

Bus #	Base case		Change cases											
	V	Θ°	'a'		'b'		'c'		'd'		'e'		'f'	
V			Θ°	V	Θ°	V	Θ°	V	Θ°	V	Θ°	V	Θ°	
1	1.060	0	1.060	0.000	1.060	0.000	1.060	0.000	1.060	0.000	1.060	0.000	1.060	0.000
2	1.045	-4.98	1.035	-12.576	1.035	-5.721	1.045	-3.098	1.045	-4.012	1.045	-4.259	1.045	-4.622
3	1.010	-12.74	1.010	-12.740	1.010	-12.740	1.010	-12.740	1.010	-12.740	1.010	-12.740	1.010	-12.740
4	1.014	-10.28	1.011	-13.603	1.000	-12.238	1.013	-9.341	1.002	-11.855	1.007	-10.909	1.014	-9.032
5	1.017	-8.76	1.013	-12.185	0.997	-11.670	1.016	-7.815	1.008	-9.624	1.006	-9.968	1.017	-7.855
6	1.064	-14.22	1.056	-16.521	1.046	-16.032	1.065	-13.588	1.056	-14.888	1.055	-14.948	1.066	-13.573
7	1.047	-13.34	1.041	-15.684	1.033	-14.709	1.046	-12.480	1.036	-14.304	1.040	-13.693	1.048	-12.273
8	1.076	-13.34	1.071	-15.684	1.063	-14.709	1.076	-12.480	1.066	-14.304	1.070	-13.693	1.077	-12.273
9	1.034	-14.92	1.026	-16.786	1.021	-16.010	1.035	-14.133	1.024	-15.592	1.028	-15.160	1.036	-13.980
10	1.032	-15.08	1.024	-17.030	1.018	-16.311	1.032	-14.322	1.022	-15.759	1.025	-15.414	1.034	-14.194
11	1.044	-14.78	1.036	-16.900	1.028	-16.299	1.045	-14.078	1.035	-15.448	1.036	-15.307	1.046	-14.006
12	1.050	-15.07	1.042	-17.121	1.033	-16.687	1.051	-14.512	1.042	-15.669	1.041	-15.723	1.051	-14.498
13	1.046	-15.15	1.040	-16.951	1.032	-16.586	1.046	-14.672	1.040	-15.691	1.039	-15.739	1.047	-14.659
14	1.036	-16.02	1.036	-16.020	1.036	-16.020	1.036	-16.020	1.036	-16.020	1.036	-16.020	1.036	-16.020

TABLE III
OPTIMAL POWER DISPATCH IEEE 14 BUS TESTING SYSTEM

	Optimal Dispatch of Generation							
	Total syst. lost (MW)	Gen. costs (\$/h)	Gen.1	Gen.2	Gen.3	Gen.4	Total syst. lost (MW)	Gen. costs (\$/h)
Base	9.337	2114.42	98.9274	145.8090	0	36.7379	6.2743	1915.02
1-2	9.34107	2312.29	26.0660	59.3641	80.0000	100.0000	6.4301	1920.15
1-5	12.6659	2470.87	26.8384	59.8297	80.0000	100.0000	7.66818	1924.28
2-3	9.71649	2399.79	64.4019	106.4036	80.0000	22.1906	13.9961	2098.58
2-4	12.6514	2656.41	34.2384	67.8714	71.4119	100.0000	14.5217	1953.21
2-5	13.0257	2734.10	65.4038	104.7371	4.7305	100.0000	15.8714	2082.55
3-4	11.5618	2685.69	63.0421	99.2438	80.0000	39.9413	23.2272	2091.04
4-5	12.3594	2628.18	49.3121	87.0980	80.0000	58.0932	15.5033	2016.48
4-7	12.9599	2757.02	40.9473	72.7593	64.0466	100.0000	18.7532	1975.67
4-9	13.0459	2785.81	57.6825	91.8748	40.7024	100.0000	31.2597	2060.94
5-6	13.2414	2655.61	31.3359	64.4313	79.0129	100.0000	15.7802	1952.34
6-11	13.4112	2809.56	95.3048	142.0202	0	46.2961	24.621	2291.99
6-12	13.4527	2809.48	89.5617	136.0297	0	60.5402	27.1316	2257.15
6-13	13.4859	2786.75	68.9125	113.2231	17.6995	91.9853	32.8204	2139.54
7-9	12.8181	2752.35	37.0805	69.3306	76.1151	100.0000	23.5262	1981.71
9-10	13.4851	2818.26	101.8231	148.1213	0	30.4088	21.3532	2332.89
9-14	12.9519	2781.84	64.4334	105.1067	28.9804	94.6953	34.2158	2109.95
10-11	13.3275	2811.88	97.3853	144.3516	0	40.5256	23.2625	2305.35
12-13	13.3253	2813.38	97.4340	144.3467	0	40.4616	23.2424	2305.47
13-14	13.0528	2793.23	78.8329	122.7553	12.1535	76.8839	31.6255	2188.92

VII. CONCLUSION

This research promotes the use of multiagent systems based on the performance on less time consuming. Well organization of agents is the requirement for this argument. The decision when MAS processing is used is faster and accurate based on the to the negotiation model developed in each agent process. The technique is a promising towards the online contingency analysis.

REFERENCES

- [1]. F. Wu, C. Yeung, A. Poon, and J. Yen, "A Multi-agent Approach to the Deregulation and Restructuring of Power Industry," *31st Annual Hawaii International Conference on System Sciences, (HICSS)*, Vol. 3, pp. 122, 1998.
- [2]. A. Abur, and A. G. Exposito, *Power System State Estimation Theory and Implementation*, Marcel Dekker, Inc., 2004.
- [3]. M. Shahidehpour, and Y. Wang, *Communication and Control in Electric Power Systems: Applications of Parallel and Distributed Processing*, John Wiley & Sons, Inc., 2003.
- [4]. M. Wooldridge, *Introduction to Multi-Agent Systems*. John Wiley & Sons Inc., 2002.
- [5]. Z. Yong-jun and R. Zhen, "Real-time Optimal Reactive Power Dispatch Using Multiagent Technique," *Electric Power Systems Research*, Vol. 69, Issues 2-3, pp. 259-265, May 2004.
- [6]. C. Rehtanz, *Autonomous Systems and Intelligent Agents in Power System Control and Operation*, Springer-Verlag Berlin Heidelberg New York, 2003.
- [7]. A. Oonsivilai, and M.E. El-Hawary, "A Self-Organizing Fuzzy Power System Stabilizer", *IEEE CCECE'98*, 1998.
- [8]. A. Oonsivilai, and M.E. El-Hawary, "Power System Dynamic Load Modelling using Adaptive-Network-Based Fuzzy Inference System," *IEEE CCECE'99*, 1999.

- [9]. A. Oonsivilai, and M.E. El-Hawary, "Wavelet Neural Network Based Short Term Load Forecasting of Electric Power System Commercial Load", *IEEE. CCECE'99*, 1999.
- [10]. H. L. Willis, and W. G. Scott, *Distributed Power Generation: Planning and Evaluation*, Marcel Dekker, 2000.
- [11]. A. Oonsivilai, and K. A. Greyson, "Effect of Electric Power Shedding on Economic Dispatch: Case Study Tanzania, " *ICIEA*, 2009, Nanjing, China.
- [12]. Patel, M., *Advances in the Evolutionary Synthesis of Intelligent Agents*, ed. P.J. Mukesh, V. Honavar, and K. Balakrishnan. 2001, Cambridge: