

Traffic Signal Coordinated Control Optimization: A Case Study

Pengdi Diao, Zhuo Wang, Zundong Zhang, Hua Cheng

Abstract—In the urban traffic network, the intersections are the “bottleneck point” of road network capacity. And the arterials are the main body in road network and the key factor which guarantees the normal operation of the city’s social and economic activities. The rapid increase in vehicles leads to seriously traffic jam and cause the increment of vehicles’ delay. Most cities of our country are traditional single control system, which cannot meet the need for the city traffic any longer. In this paper, Synchro6.0 as a platform to minimize the intersection delay, optimizes single signal cycle and split for Zhonghua Street in Handan City. Meanwhile, linear control system uses to optimize the phase for the t arterial road in this system. Comparing before and after use the control, capacities and service levels of this road and the adjacent road have improved significantly.

Keywords—linear control system; delay mode; signal optimization; synchro6.0 simulation

I. INTRODUCTION

AS an important part of an urban transportation network, intersection is the bottleneck of traffic capacity and it is also a place where many traffic jams and traffic accidents n take place. The scientific management and control of the intersection is a significant research subject for traffic control engineering [1]. And it is also an important measure to guarantee the traffic safety of the intersection and play a role in the traffic capacity of the intersection, and also an effective way of solving the traffic problem in city.

It is very close for the intersections in the roads of the city. Because the single point of control signals, vehicles often meet a red light, they have to stop and restart regularly, resulting in poor driving and a worse environment [2]. To reduce the stop time of vehicles in each intersection, especially on the arterial road, people connect a batch of adjacent signal intersection on a t arterial road, and try to control them, thus, the link intersection traffic signal coordination and control system appears which also named linear control or the Green Wave System.

In this paper, we make some single point of intersection signal control in urban road system which composed of Green Wave as the object of study, based on Synchro, and implement coordinated control to five intersections in Zhonghua Avenue of Handan City, China, elaborating on the idea and design methods of signal coordination and control system detailed.

Ms. Pengdi Diao is with Beijing Jiaotong University, China e-mail: 11121084@bjtu.edu.cn

II. THE INSTRUCTION OF THE METHOD OF THE CURRENT ROAD TRAFFIC SIGNAL COORDINATION

Presently, a more comprehensive foreign traffic signal control system mainly include the United Kingdom TRANSYT system, SCOOT system and the SCATS system in Australia and the Jing san system in Japan and some systems developed by other countries like USA, among them The SCOOT system in the United Kingdom and Australia SCATS system is more famous. The majority cities of our country traffic signal control system is slightly behind, which basically import foreign traffic control system. For example, from the signal number and geographic distribution of point of view in Beijing, both SCOOT and SCATS system occupy an important position in the system's signal control system in Beijing.

Although these types of systems have better control results in foreign countries, from the use of our country, these types of systems in our country's transport environment manifest some problems, which mainly reflect in the following parts:

First of all, TRANSYT system, SCOOT and SCATS system model systems are established in accordance with foreign traffic flow characteristics, and they are less adaptive for the mixed traffic flow, causing the control effectiveness of the system dramatically reduced.

Secondly, for China's huge traffic and clear temporal and spatial characteristics and the situation of extremely prone to congestion on morning and evening peak periods, although the SCOOT system provides additional means of control such as limiting, it has poor effect on saturated traffic flow actually. For the domestic traffic flow characteristics and control special needs.

Furthermore, different signal of different systems can't communicate and coordinate the optimal control each other, although the different systems of signal distribute in different regions, the junction of the regions often become the blind of coordination and control [3].

On the other hand, on the research of the traffic signal control theory, to improve the control effect, many scholars make a lot of research on control strategy and control algorithm, and achieved fruitful results. However, there has a great obstacle to the theory of control algorithm into practice. To solve the existing traffic signal controller curing process and poor scalability problems, it proposed the smallest model of single intersection delay in this paper.

III. THE MODEL OF MINIMUM INTERSECTION DELAY

When vehicles driving on the t arterial road, the drivers always hope that the stopping rate least and the delay shortest, if possible, showing that the delay is significant in traffic

control [4]. Thus, the design in this paper with the minimum average delay for objective function, quote the model of the minimum intersection delay to optimize isolated intersection.

A. Calculating the average delay time per car in intersection

Generally, there are many model to compute per vehicle's average delay of k-th imported channel in j-th phase in the intersection, this design apply Webster model, the formula as follow:

$$\delta_{jk} = \frac{C(1 - g_{ej})^2}{2(1 - \rho_{jk})} + \frac{x_{jk}^2}{2S_{jk}(g_{ej} - \rho_{jk})} - 0.65 \left(\frac{C}{q_{jk}^2} \right)^{\frac{1}{2}} \cdot x_{jk}^{(2+5g_{ej})} \quad (1)$$

Where, C is the cycle time of the timing control signal in this designed intersection on the arterial road. g_{ej} is the effective split of the j-th phase. G_{ej} is the effective green time of the j-th phase. y_{jk} is the flow ratio of the k-th approach road in the j-th phase in the designed intersection. The calculation formula such as formula (2)

$$y_{jk} = \frac{q_{jk}}{S_{jk}} \quad (2)$$

Where, S_{jk} is the saturated flow rate of the k-th approach road in the j-th phase (pcu/h). q_{jk} is the equivalent traffic of the k-th approach road in the j-th phase (pcu/h). x_{jk} is the saturation degree of the k-th approach road, The calculation formula as follow:

$$x_{jk} = \frac{y_{jk}}{g_{ej}} \quad (3)$$

B. Signal timing model of isolated intersection

The goal of this project is to make the total delay of the car which enter the intersection be minimum: $\min \sum_j \sum_k \delta_{jk} q_{jk}$. The formula of the best signal cycle can be deduced as follow [7]:

$$C_0 = \frac{1.5L + 5}{1 - Y} \quad (4)$$

$$Y = \sum \max[y_j, y'_j, \dots] \quad (5)$$

$$G_e = C_0 - L \quad (6)$$

$$G_{ej} = G_e \frac{\max[y_j, y'_j, \dots]}{Y} \quad (7)$$

$$\lambda_j = \frac{G_{ej}}{C_0} \quad (8)$$

$$G_j = G_{ej} + L_{gj} + L_y - Y \quad (9)$$

$$G_{p \min j} = \frac{D_j}{v_p} + 6 \quad (10)$$

Where, G_j is the green time of the j-th phase (s) on the arterial road in this designed intersection, L_{gj} is the initial green loss of the j-th phase (s) on the arterial road, L_y is the final yellow loss in this designed intersection, Y is the yellow time in this designed intersection, L is the total signal loss time,

which generally take the yellow time and the all-red time as the loss time, take 3s as the yellow time and all-red time is 1s. Thus, for two phase intersection, the total signal loss time is 8s. $G_{p \min j}$ is the minimum green for the people pass the pedestrian crossing corresponding to j-th phase. Calculation formula as follow:

$$G_{p \min j} = \frac{D_j}{v_p} + 6 \quad (11)$$

Where, D_j corresponding to the maximum of pedestrian crossing of the j-th phase(m), v_p is the speed of the elderly or school children across the street, the minimum value (1.2m/s) is adopted [5-6].

IV. THE SIMULATION AND EVALUATION

A. The information of the traffic status

In Handan City, Zhonghua Street is a hub of communications, it owns numerous public entertainment sites. The geographic location of this arterial road is very important, how do we make it safe, unimpeded, rapid and convenience through improving the traffic management measures, especially the control mode of the intersection signal in the condition of maintaining existing traffic facilities has important economic value and social significance. Therefore, this paper aims at studying arterial road between Zhonghua Street – Peace Road intersection and Zhonghua Street–Zhuhe Road intersection for working on this subject. This arterial road is shown in Fig. 1. The arterial roads are mentioned in the following sections in this paper all means this arterial road. The arterial road is in north-south direction and in a bidirectional six-lane. There are five signalized intersection, one non-signalized intersection, the traffic control form of the arterial road all belong to separation between motor vehicle and non-motor vehicle. The traffic flow diagram of the intersection is shown in Fig.2 and the Current situation of the intersection is shown in Fig.3.



Fig. 1 The intersections between Zhuhe Road and Heping road of the Zhonghua Street in Handan City

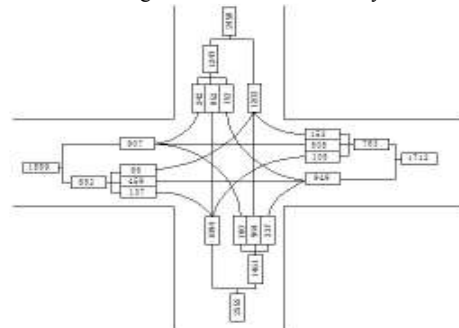

Fig. 2 Traffic flow diagram of the intersection

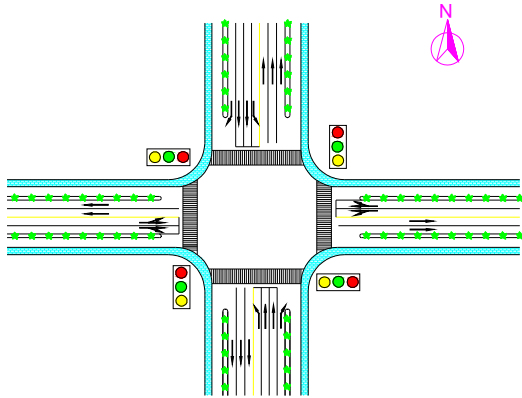

Fig. 3 Current situation of the intersection

B. Simulate isolated intersection based on Synchro system

Synchro6 simulation software is the ideal tool for signal timing and optimization, which has coordination control simulation, traffic capacity analysis simulation, adaptive signal control simulation and other functions. Meanwhile, it owns many interfaces can be directly connected to traditional traffic simulation software, such as CORSIM, TRANSYT-7F, HCS, etc. It is of high maneuverability and has the actual application value.

According to statistical data we can obtain, the topology of the designed intersection (Zhonghua Street–Zhuhe Road intersection) is shown in Fig. 2. When the relevant parameters were input, we can get the results and service level after and before the timing optimization of the designed intersection, which is shown in Fig.4 and Fig.5.

Comparing the simulation parameters, we can see that the control effect has been significantly improved after the signal optimization, the delay decreased from 29.6 s to 19.2 s, service level have adjusted from class B to grade C, which has been improved to a higher level. Similarly, using the Synchro system optimize the signal each intersection.

C. Calculate offsets by Algebraic method

Algebraic method determines the best public signal cycle and offset by seeking the ideal intersection distance which match with the actual intersection distance best, in order to make the arterial coordination and control system get the greatest possible bandwidth and the ideal coordination and control effects [8-9]. The steps are as follows:

- 1) Determine the initial public signal cycle;
- 2) Determine the ideal distance between the intersection is, where V is the speed for passing green wave bandwidth $\left[\frac{C_1}{2} - M, \frac{C_1}{2} + M \right]$ and M is the range of the floating change;

- 3) Get the best ideal value of the intersection spacing a_{opti} , and make sure the best ideal intersection spacing match with the actual distance between the intersection best a_{opti} ;
- 4) Determine the best public signal cycle of the final selection a_{opti} ;
- 5) According to the location relative to the ideal intersection in which the position located, we determine the phase size.

Options >	TIMING WINDOW	EBL	EBT	EBR	WBL	WBT	WBR	NBL	NBT	NBR	SBL	SBT	SBR	PED	HOLD
Controller Type:	Perm	Perm	Perm	Perm	Perm	Perm	Perm	Perm	Perm	Perm	Perm	Perm	Perm	Perm	Perm
Cycle Length: 79.0	Protected Phases	4	4	0	0	0	0	2	2	6	6	6	0	0	
Actuated C.L.: 59.0	Detector Phases	4	4	0	0	0	0	2	2	6	6	6	0	0	
Natural C.L.: 45.0	Minimum Initial (s)	4.0	4.0	0	0	0	0	4.0	4.0	4.0	4.0	4.0	0	0	
Max v/c Ratio: 1.36	Minimum Split (s)	22.0	22.0	0	0	0	0	22.0	22.0	22.0	22.0	22.0	0	0	
Int. Delay: 29.6	Total Split (s)	45.0	45.0	0	0	0	0	44.0	44.0	44.0	44.0	44.0	0	0	
ICU LOS: C	Yellow Time (s)	3.0	3.0	0	0	0	0	3.0	3.0	3.0	3.0	3.0	0	0	
ICU LOS: E	All Red Time (s)	2.5	2.5	0	0	0	0	2.5	2.5	2.5	2.5	2.5	0	0	

Fig. 4 The timing and delay of the intersection before optimization

Options >	TIMING WINDOW	EBL	EBT	EBR	WBL	WBT	WBR	NBL	NBT	NBR	SBL	SBT	SBR	PED	HOLD
Controller Type:	Lanes and Shoring (BRL)	Perm	Perm	Perm	Perm	Perm	Perm	Perm	Perm	Perm	Perm	Perm	Perm	Perm	Perm
Cycle Length: 79.0	Traffic Volume (vph)	86	459	137	105	505	153	160	964	337	153	852	242	0	
Actuated C.L.: 79.0	Turn Type	Perm	Perm	Perm	Perm	Perm	Perm	Perm	Perm	Perm	Perm	Perm	Perm	Perm	
Natural C.L.: 59.0	Protected Phases	4	4	0	0	0	0	2	2	6	6	6	0	0	
Max v/c Ratio: 0.89	Detector Phases	4	4	0	0	0	0	2	2	6	6	6	0	0	
Int. Delay: 19.2	Minimum Initial (s)	4.0	4.0	0	0	0	0	4.0	4.0	4.0	4.0	4.0	0	0	
ICU LOS: B	Minimum Split (s)	22.0	22.0	0	0	0	0	22.0	22.0	22.0	22.0	22.0	0	0	
ICU LOS: E	Total Split (s)	38.0	38.0	0	0	0	0	41.0	41.0	41.0	41.0	41.0	0	0	
ICU LOS: E	Yellow Time (s)	3.0	3.0	0	0	0	0	3.5	3.5	3.5	3.5	3.5	0	0	
ICU LOS: E	All Red Time (s)	2.5	2.5	0	0	0	0	2.5	2.5	2.5	2.5	2.5	0	0	

Fig. 5 The timing and delay of the intersection after optimization

Through the above steps, we result the following tables according to calculation.

TABLE I
ALGEBRAIC METHOD DETERMINES THE OFFSET

intersection	A	B	C	D	E	intersection	A	B	C	D	E
a	47	36	46	42		a	47	36	46	42	b
44	3	39	41	13	26	55	47	28	19	6	19
45	2	38	39	36	34	56	47	27	17	3	20
46	1	37	37	33	32	57	47	26	15	0	21
47	0	36	35	30	30	58	47	25	13	55	22
48	47	35	33	27	27	59	47	24	11	53	23
49	47	34	31	24	24	60	47	23	9	51	24
50	47	33	29	21	21	61	47	22	7	49	25
51	47	32	27	18	18	62	47	21	5	47	26
52	47	31	25	15	16	63	47	20	3	45	25
53	47	30	23	12	17	64	47	19	1	43	24
54	47	29	21	9	18						

TABLE II
CALCULATE THE GREEN OFFSET

intersection	A	B	C	D	E
number of ideal signal	1	2	3	4	5
position of each signal	right	right	left	left	left
Split(%)	55	44	62	42	48
Loss(%)	8	12	8	6	12
effective split(%)	47	32	54	36	36
green offset(%)	22.5	28	19	29	26

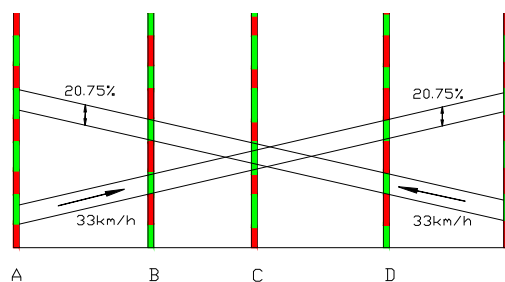

Fig. 7 Calculation results by Algebraic method in time-space diagram

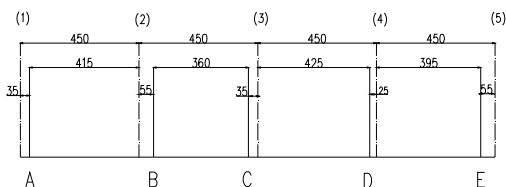

Fig. 6 The relative position between the ideal signal and the actual signal

D. The optimization of Synchro simulation offset

As the offset involves coordination between multiple intersections, it is called the Network Offsets in Synchro, we can optimize the offset after Synchro set the cycle time must be determined. After delay is optimized by linear system [10], the results are shown in table III.

We use Synchro system simulating five intersections before and after linear control, the results shown in Table III, From Table III we can see that the intersection of the indicators has been significantly improved after the linear control. Five north-south t arterial road intersection delay reduction 36.6% after the linear control, and intersection level of service improved.

V. SUMMARY

This paper quotes the minimal delay model of isolated intersection, combined with the survey data of Zhonghua Street in Handan City, optimize the signal timing for every individual intersection, for example, Zhonghua Street-Zhuhe Road intersection, and compare with the traffic conditions after the linear control in using simulation method of Synchro software. The results show that this method significantly improved the intersection delays and traffic capacity, and improve intersection level of service. However, the actual traffic conditions are much more complex. In addition to the linear control, area control is also needed in the actual intersection coordination, which is a future research direction.

ACKNOWLEDGMENT

The paper is finished under the guidance of Wang Zhuo associate professor. Professor Wang give elaborate guidance and valuable opinions in the writing process. Moreover, Zhao YaLong and Liu Chengkun give me numerous help. Here my sincere thanks to Professor Wang and my classmates.

TABLE III
THE COMPARISON OF DELAY AND SERVICE LEVEL BETWEEN BEFORE AND AFTER THE LINEAR CONTROL

	A		B		C		D		E		situations after improvement
	before	after	before	after	before	after	before	after	before	after	
intersection delay	29.6	19.2	25.8	16.9	25.1	12.1	18	19.3	24.9	19.3	reduce 36.6s
level of service	C	B	C	B	C	B	B	B	C	B	improve a service level

REFERENCES

- [1] Husham N. Abdulsattar. Pedestrians' Right-of-way at Signalized Intersections. *TRB*,2000
- [2] Indumathi T. S., T. Srinivas, and B. Siva Kumar, Routing Capability and Blocking Analysis of Dynamic ROADM Optical Networks(Category - II) for Dynamic Traffic, *World Academy of Science, Engineering and Technology* 52 2009
- [3] Daganzo C.F, "The cell transmission model: a simple dynamic representation of highway traffic consistent with hydrodynamic theory," *Transportation Research* 28B (4), 1994. pp. 269-287
- [4] Farges, J.I, Henry J.J, Tufal, J, "The PRODYN real-time traffic algorithm in Proceedings of the 4th IFAC Symposium on Transportation System," *Baden-Baden, Germany*,1983, pp. 307-312
- [5] Teply,S, and Hunt J.D, Reviewing the basic of signal coordination: throughbands, greenbands and cyclic flow profiles, *Management and control of urban traffic system*, 1987. 197~215
- [6] Ball, Marring V. Day, Pushkin, Tung shengYu, Robust control for signalized intersections.*SPIEVOL*.3207.
- [7] Shao Changqiao, Rong Jian, and Zhou Jian, "Stochastic analysis of signalized intersection traffic capacity," in *BeijingUniversity of Technology*,vol.32,2006.
- [8] DENG Jiangsha, YAO Gang, "Application of Improved Ant Colony Optimization Algorithm to Solve Traveling Agent Problem," *Computer Technology and Development*, 2006, 16(7): 233-255.
- [9] LI Lin; Xu Jianmin, Lu Kai."An Improved Algebraic Method of Green Wave Based on One-Phase-One-Approach" in *Computer And Communications*,vol. 27, 2009.
- [10] Reginald D. Smith, Data Traffic Dynamics and Saturation on a Single Link, *World Academy of Science, Engineering and Technology* 51 2009

Pengdi Diao, born in Xinji, Hebei Province, is a MS student in School of Traffic and Transportation, Beijing Jiaotong University, Majoring in Safety Technology and Engineering .

Zhuo Wang is an associate professor with Beijing Jiaotong University, interested in Safety Technology and Engineering, Traffic Safety Engineering, Railway Intelligent Transportation System.