

Optimization Based Obstacle Avoidance

R. Dariani, S. Schmidt, R. Kasper

Abstract—Based on a non-linear single track model which describes the dynamics of vehicle, an optimal path planning strategy is developed. Real time optimization is used to generate reference control values to allow leading the vehicle alongside a calculated lane which is optimal for different objectives such as energy consumption, run time, safety or comfort characteristics. Strict mathematic formulation of the autonomous driving allows taking decision on undefined situation such as lane change or obstacle avoidance. Based on position of the vehicle, lane situation and obstacle position, the optimization problem is reformulated in real-time to avoid the obstacle and any car crash.

Keywords—Autonomous driving, Obstacle avoidance, Optimal control, Path planning.

I. INTRODUCTION

HUMAN error is the main reason of accident which cause 93.5% of accident based on Audi accident research. Drowsiness and distraction as the driver states are relevant cause of traffic crashes, 15% and 18% of accidents reason each respectively. NHTSA 2008 shows that driver is involved in at least one non-driving activity in 18% of cases. Pedestrian and cyclist as an important part of traffic system need more focus because one pedestrian life lost every two hours in United States and high number of fatalities and injuries for cyclist [1]. These are the main reasons that modern vehicle are equipped with an increasing number of sensors to sense surroundings such as radar, lidar, computer vision sensors and GPS and also are equipped with driving assistant systems such as navigation systems, intelligent speed adaptation, electronic stability control and etc. A further development of these systems is autonomous driving which means driving without or very limited intervention of driver.

Classical approaches for path planning [2] are mainly rules and maneuvers based. However predefining all the critical situation is not feasible, this is why in this research work the autonomous driving is based on mathematic formulation which allows taking decision on unforeseen situations and restrictions related to the road in the case of obstacles, sudden change on the road or other vehicles, which maybe not all covered by predefined rules. Based on the dynamic vehicle model, the geometric data of the track as the known input is delivered to the path optimization level by e.g. a navigation

system or digital map. Then, based on delivered data in the path optimization level, steering angle and driving force as the inputs of the systems are calculated. These allow leading the vehicle alongside a calculated lane which is optimal for different objectives as energy consumption or comfort and allows taking into account some constraints as width of the lane or maximal lateral or longitudinal acceleration.

There is no guarantee that vehicle behavior matches perfectly with the optimal solution found by optimization algorithm due to the model uncertainty or environment disturbances such as different road friction and side wind. This is why a closed loop path control system is provided to generate additional inputs, force and steering angle, in order to correct the longitudinal and lateral distance error. Fig. 1 shows the general hierarchical concept of autonomous driving used in this research work.

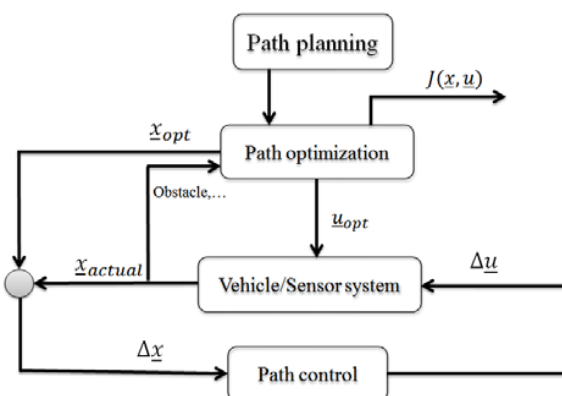

Fig. 1 General hierarchical concept of autonomous driving

The optimal problem due to the big dimension of the system and length of course is numerically hard to solve and require more calculation time to find optimal solution. In another hand optimal problem must be updated frequently to consider the dynamic behavior of road and environment. To solve the problem in an easier way and make the system real-time capable, a “moving horizon approach” is used, in which global optimization problem is partitioned into a sequence of local optimization problems with an adequate smaller horizon. Updating and solving the problem with small horizon offers the possibility to update lane status which is useful in the case of sudden changes, obstacle or other vehicles in the lane.

In the case of another vehicle on the road as a moving obstacle or in the case of fix obstacle, the optimization problem is updated and reformulated by considering the obstacle in the objective function in order to avoid it. Based on the obstacle position and its distance to our vehicle a penalty function is added to optimization problem.

R. Dariani is research assistant at the University of Magdeburg, Germany. (phone: +493916752084; fax: +493916712656; e-mail: reza.dariani@ovgu.de)

S. Schmidt is assistant Professor “Autonomous Vehicles” at the University of Magdeburg, Germany (phone: +493916752084; fax:+493916712656; e-mail: stephan.schmidt@ovgu.de).

R. Kasper is professor and head of chair of mechatronics at University of Magdeburg, Germany (phone: +493916752606; fax: +493916712656; e-mail: roland.kasper@ovgu.de).

The outline of the paper is as follows. Section II describes the vehicle model, Section III explain path planning strategy. Obstacle avoidance strategy for fix and moving obstacles and also for pedestrians and bicycles is explained in Section IV with simulation results, and finally Section V concludes the paper.

II. VEHICLE MODEL

Non-linear single track model [3] presented by Rieckert and Schunk [4] is used to describe the vehicle model. F_{DR} and F_{LX} present the driving force or longitudinal force applied to vehicle and load force caused by wind, gravity or friction respectively. The vehicle is regarded as a rigid body moving in xy -plane. To simplify the model front and rear wheels are summarized to one single wheel each, which leads to a so called "bicycle model". In this model, roll and pitch angle are neglected and the tire dynamics are approximated by a linear tire characteristic with saturation.

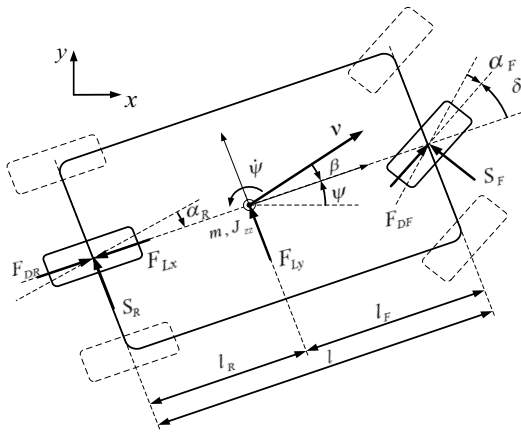

Fig. 2 Vehicle nonlinear single track model

The system states are the coordinates of the center of gravity x and y in a global coordinate system. The yaw angle ψ and associated yaw rate $\dot{\psi}$, describe the orientation of the vehicle in xy -plane. The actual velocity of the vehicle is v and β is the attitude angle which describes the difference between yaw angle and track angle, which is the result of the side forces S_F and S_R in lateral direction. The side forces are linear functions of the corresponding slip angles α_F and α_R , which are in turn nonlinear functions of the state variables β , $\dot{\psi}$ and v and steering angle δ .

The nonlinear system

$$\dot{\underline{x}} = f(\underline{x}, \underline{u}) \quad (1)$$

with state vector \underline{x}

$$\underline{x} = [\beta \psi \dot{\psi} v x y]$$

and input vector \underline{u}

$$\underline{u} = [\delta F_{DR}]^T$$

is described as

$$\begin{aligned} \ddot{\psi} &= \frac{1}{J_{zz}} (S_F l_F - S_R l_R) \\ \dot{v} &= \frac{1}{m} (F_{DR} - F_L) \\ \dot{x} &= v \cos(\psi - \beta) \\ \dot{y} &= v \sin(\psi - \beta) \end{aligned} \quad (2)$$

where m is the vehicle mass and J_{zz} is the moment of inertia.

III. PATH PLANNING STRATEGY

The objective of path planning strategy is to generate reference actuation values by taking into consideration boundaries and constraints which allow vehicle leading on an ideal curve. The ideal curve is the numerical solution of an optimal control problem, where driver is modeled as penalty function, and car is given as the dynamic system (1).

The optimization problem is given as

$$\min J(\underline{x}, \underline{u}) \quad (3)$$

with nonlinear constraints

$$\begin{aligned} \dot{\underline{x}} &= f(\underline{x}, \underline{u}) \\ \underline{g}_l &\leq \underline{g}(\underline{x}, \underline{u}) \leq \underline{g}_u \end{aligned} \quad (4)$$

as well as state and input restrictions

$$\begin{aligned} \underline{X}_l &\leq \underline{x} \leq \underline{X}_u \\ \underline{U}_l &\leq \underline{u} \leq \underline{U}_u \end{aligned} \quad (5)$$

Objective function definition is critical to find the ideal trajectory. In the first step the main focus is on the quantification of control effort. In order to avoid trivial solution of standstill, a new term is added to objective function in which the aim is to maximize the driving distance of the vehicle as presented in (6):

$$J(\underline{x}, \underline{u}) = \int_{t_0}^{t_f} \underline{u}^T \cdot \underline{R} \cdot \underline{u} dt - \int_{t_0}^{t_f} v dt \quad (6)$$

Equation (6) results to an optimal solution where most distance is covered with minimal control inputs. \underline{R} in (6) is the weight matrix to manipulate the effect of each term in objective function. The exact choice of the individual weights strongly depends on the actual driving task and the preferences of the user. It is always a compromise between different objectives and not every combination is useful.

To describe the road characteristic, a path parameter $\theta(t) = \int_{t_0}^{t_f} v dt$ is defined, which reflects the travelled distance on the track. With the help of this parameter road boundaries can be described and introduced as non-linear states constraints into optimal control problem.

With the given center line of the track:

$$\begin{aligned} x_m &= f_x(\theta) \\ y_m &= f_y(\theta) \end{aligned} \quad (7)$$

$$\varphi_m = f_\varphi(\theta)$$

and the actual position of the vehicle is possible to calculate the actual lateral distance $a(\underline{x}, \theta)$ of the vehicle from the track center line:

$$a(\underline{x}, \theta) = -\sin(\varphi_m(\theta)) \cdot [x_m(\theta) - x] + \cos(\varphi_m(\theta)) \cdot [y_m(\theta) - y] \quad (8)$$

To keep the vehicle within the road permissible road width, B , lateral distance of the vehicle based on the center line must be calculated. Then, the road boundaries can be formulated as

$$-\frac{B(\theta)}{2} \leq a(\underline{x}, \theta) \leq \frac{B(\theta)}{2} \quad (9)$$

Additional constraints like maximal longitudinal or lateral accelerations or other state constraints depending on the path parameter θ , like statutory speed limit, can explicitly be taken into account. To make the system faster and real time capable, all these constraints and boundaries, such as road boundaries or velocity limitation due to security, are added to the objective function by a penalty function, representing so called soft constraints. The advantages of soft constraints comparing to hard constraints, is that they don't need to be exact in each time step, thus avoiding a lot of iterations during optimization. In the case that the numerical value of these constraint and boundaries exceed the permitted value, their penalty function cost in objective function push them back within the permitted values.

While cornering, the covered distance can be different from the covered distance on the centerline of the track. This different may influence the road boundaries definition. So it is necessary to correct the path parameter at the transition points of the moving-horizon approach. This is explained below, with the help of the vehicle's longitudinal distance $s(\underline{x}, \theta)$ from the given centerline:

$$s(\underline{x}, \theta) = \cos(\varphi_m(\theta)) \cdot [x_m(\theta) - x] + \sin(\varphi_m(\theta)) \cdot [y_m(\theta) - y] \quad (10)$$

Due to the high length of test course and high dimension of the system, the complete optimization problem is very large and numerically difficult to solve and it would need a long optimization time. A possibility to handle this problem is using the moving horizon approach [5]. In this approach, Fig. 3, the global optimization problem covering the complete driving task is portioned into sub-problems of $\tau = 2 \dots 3s$ each, which are easier to solve (see Fig. 3). The solution for each ξ is saved and used to update the initial solution for the next horizon. Consequently the problem is solved for τ seconds and updated each ξ seconds. An additional advantage is that the decomposition into sub-problems makes the procedure real-time capable. Updating and solving the problem with a small horizon offers the possibility to take into consideration outside influence such as other vehicle or obstacle, promptly in the optimization problem. The choice of the horizon parameter τ and increment ξ has a significant influence on the optimization problem [6]. If the chosen τ is

big means solving a big sub problem which require more computation time, and if it is small, means finding only a local optimal solution and not the global one. Big ξ reduce the computing time but the update rate will be slower, and so small ξ increase update rate but also computation time.

To solve the optimization control problem defined by equations 3 to 10, a solver based on NLPQLP by Schittkowski [10] is used, which is a high performance FORTRAN library, in which the optimal control problem is discretized and transformed into a finite dimensional non-linear optimization problem.

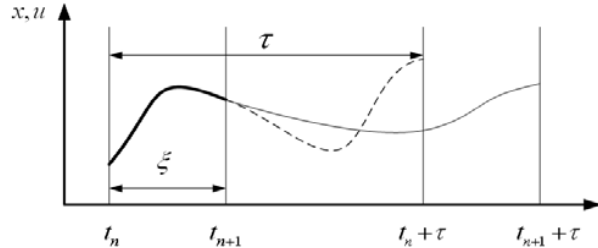

Fig. 3 Moving horizon approach

The vehicle behavior can be different from the optimization result, mainly by disturbances such as different road friction, side wind or model uncertainly. This is why a closed control loop is added to the system. The position error in longitudinal direction is mainly caused by difference of velocity and the effect of yaw angle can be neglected. Error in lateral direction is caused mainly by failure of yaw angle. Fig. 4 shows the general concept of path controller, in which the position error in lateral and longitudinal direction is measured by comparing actual and reference position of the car. These errors are sent to the lateral and longitudinal controller and additional steering angle and force are generated respectively to omit these errors.

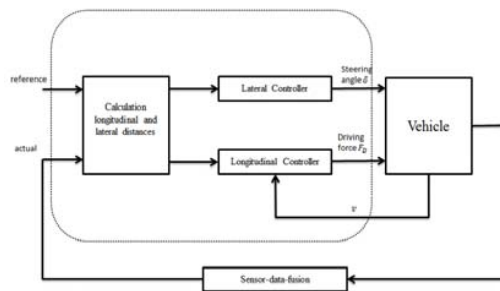

Fig. 4 Path controller

The presented strategy performance has been tested by basic driving task in simulation and real-time experiments using a real time framework under c++ [5]-[7].

IV. OBSTACLE AVOIDANCE STRATEGY

In autonomous driving, lane situation must be taken into consideration inside the optimization problem. The optimization problem has to be reformulated online in the case

of obstacle detection to generate a new ideal path. Obstacles can be detected with ranging sensors such as sonar, infrared, or radar system. The focus on this paper is not on obstacle detection, but obstacle avoidance, thus the obstacle situation is predefined and will be delivered by adequate sensors.

As explained in previous chapter, moving horizon approach offers the possibility to solve the optimal problem for a given time τ and update the problem for each ξ . During this update process, in the case of obstacle, the optimal control problem is reformulated by considering the obstacle avoidance in objective function.

There are different methods to avoid the obstacle such as neural network [10], potential field [8], velocity obstacle [9] and etc. Each of these methods has its own advantages and disadvantages. In our case, being real time is the most important fact that is highly dependent on the simplicity of the formulation. This is why a kind of potential field with one degree of freedom, which is distance, is used. Based on the distance between the obstacle and vehicle, a security region around the obstacle is considered to be avoided by a penalty in objective function. To create this security region, size of vehicle is added to the size of obstacle, and the vehicle is considered as a point on its center of gravity. Then based on this size the security region is generated.

To make the calculation time more efficient, the angle between the vehicle and obstacle, and the distance are calculated in the polar coordinate. The security region can be considered as circle [5], ellipse, rectangle or soft rectangle which means rectangle with elliptical corners. Considering a circle as a security region has the advantage that circle formulation is not complicated and requires less calculation time, but has lack of accuracy. Considering a circle with the size of obstacle plus vehicle can block completely the road and cause a complete brake and stop even if in reality there is enough space to pass by the obstacle. To avoid these problems new shapes of security region, ellipse, rectangle, soft rectangle, are suggested.

Equation (11) describes the objective function with obstacle avoidance penalty function

$$J(\underline{x}, \underline{u}) = \int_{t_0}^{t_f} \underline{u}^T \cdot R \cdot \underline{u} dt - \int_{t_0}^{t_f} v dt - \sum_i^n \int_{t_0}^{t_f} R_{dist,i} dt \quad (11)$$

$R_{dist,i}$ is the obstacle penalty value for a single obstacle i , which has a non-linear form (Fig. 5). When the vehicle is far enough from the obstacle, this value is equal to zero and obstacle does not have any influence on cost function. When vehicle is close enough to obstacle, in other words, is inside the security region, the value of R_{dist} increase, which means, obstacle avoidance is taken into consideration more and force the optimization solver to avoid the obstacle.

For fix obstacles such as parked cars, their position during optimization horizon is fixed. Moving obstacles have individual velocity, additionally initial position and orientation. Actual position of the obstacle must be predicted

during each optimization increment. This can be done with different hypothesis e.g. the obstacle is keeping its actual velocity and orientation.

In our approach we used the hypothesis, that the obstacle is keeping its actual lane. In the case of pedestrian is important to consider that human move slower than cars but possibly in a homologue way, which makes the prediction harder. A small increment ξ , which allows a continuous update, helps to avoid critical situations which are caused by prediction errors. When more than one obstacle is detected, each of them can be dealt with a penalty function, which permits the optimization to avoid each of them.

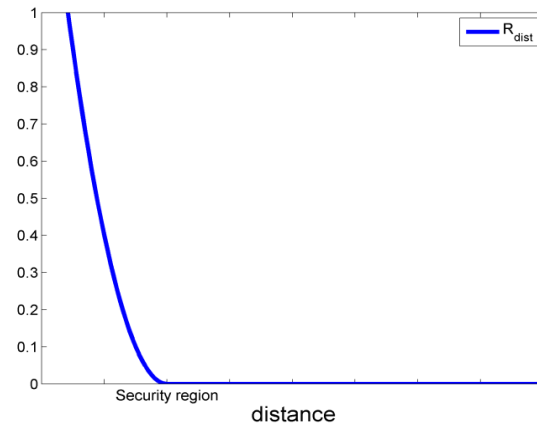

Fig. 5 Obstacle avoidance penalty function

Figs. 6-8 show the fix obstacle avoidance by applying different security regions such as ellipse, soft rectangle and ellipse respectively.

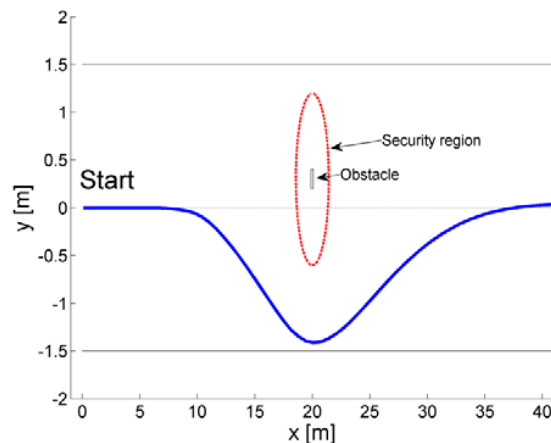

Fig. 6 Obstacle avoidance with elliptical security region

As showed in all the cases the obstacle is avoided. Ellipse is more suitable because of its simple formulation which needs less calculation time comparing to soft rectangle and rectangle. Ellipse is used for the next simulation results. Fig. 9 shows the simulation results in the case of multi obstacles, here two obstacles. In this simulation the initial velocity of the

vehicle is 14 m/s which is maximum urban velocity (50 km/h). To make this case more critical, first obstacle blocks the upper part of the lane and second obstacle, which is ten meter after first obstacle, blocks the lower part of the lane.

position of the obstacle. As it shown, before that any collision happens, the vehicle passes by the obstacle and after passing the obstacle, it returns back to the center line. Time and velocity data of the vehicle and obstacle are shown in lower and upper part of center line of the track respectively.

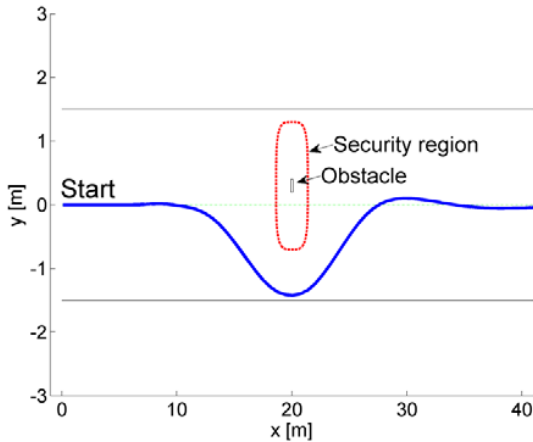

Fig. 7 Obstacle avoidance with soft rectangle security region

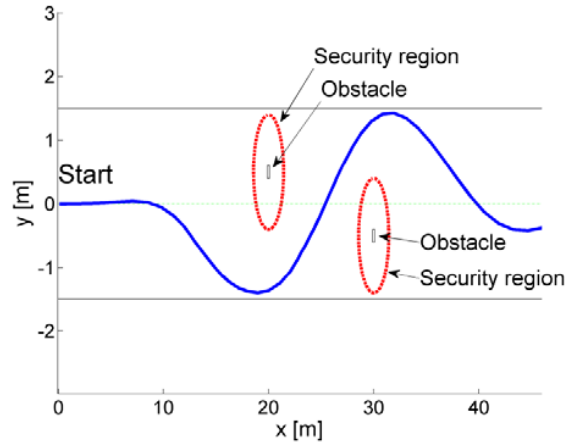

Fig. 9 Multi obstacle avoidance

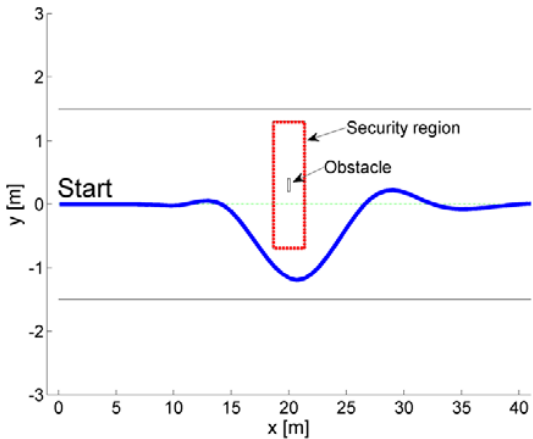

Fig. 8 Obstacle avoidance with rectangle security region

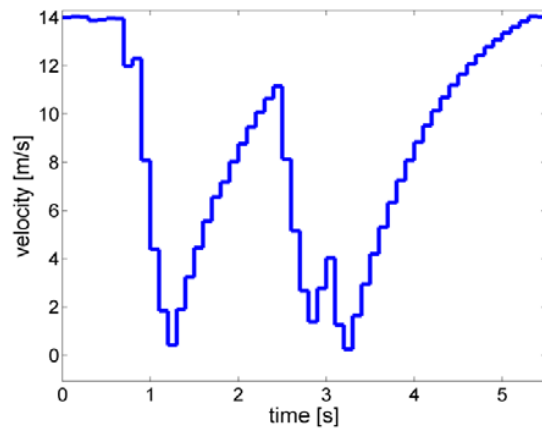

Fig. 10 Vehicle velocity for multi obstacle avoidance

As shown in Fig. 10 the velocity of the vehicle is 14 m/s, after to avoid the first obstacle is reduced to make the possibility to steer and pass by the first obstacle, then is increased. When the second obstacle is detected, the velocity is reduced again; vehicle steers to pass by the second obstacle and after passing by the second obstacle, velocity reaches its maximum.

Pedestrian and bicycle must be considered as the obstacle for security reason as well. Both can cross the street in a not predictable way, in this case, in order to increase the security and safety is better to brake completely, let the bicycle or pedestrian pass and after this continues the course again.

Another critical situation could be a moving obstacle, in the same lane but in another direction, Fig. 11, which moves with the fix velocity, here 4[m/s]. To avoid the moving obstacle the same strategy as in the case of fixed obstacle is applied. Based on the size of the obstacle plus the size of the vehicle, an ellipse is considered around the obstacle and the vehicle is considered as the center of the gravity. A penalty function is added to the objective function to avoid any collision. The blue stars on the figure shows the position of the vehicle with a given sample time, here 1 second, and the red points are the

Fig. 12 shows the simulation results of obstacle avoidance in the case of cyclist. The same approach can be used for the pedestrian. As it is shown, the cyclist cross the lane with the velocity of 2 m/s and the velocity of the vehicle is limited to 6.5 m/s. Blue stars and red circles show the position of the vehicle and bicycle by a given sample time respectively.

At beginning when the bicycle is not inside the lane, the vehicle accelerates to reach its maximum velocity. Then the bicycle enters inside the lane boundaries and after inside security region, so the objective function is reformulated by considering the obstacle. The distance between the vehicle and bicycle is calculated in each increment and based on this

distance, obstacle penalty function generate a cost on objective function to avoid the obstacle. In the case of bicycle or pedestrian, fully brake is preferred than avoiding by maneuver, this is why the velocity of vehicle is reduced, which means waiting for completely passing of bicycle. When the bicycle passes the security region, the penalty function of obstacle doesn't cost anymore, this is why the vehicle starts to accelerate again and reach its maximum velocity.

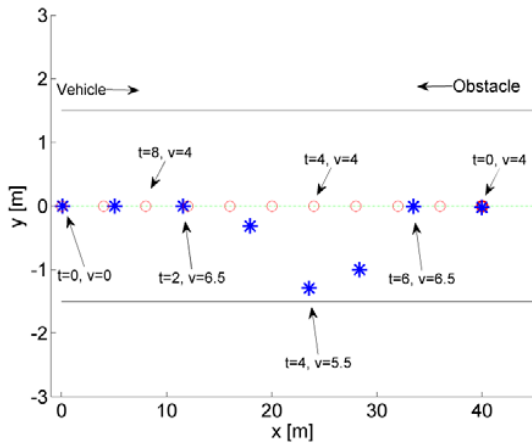

Fig. 11 Moving obstacle avoidance

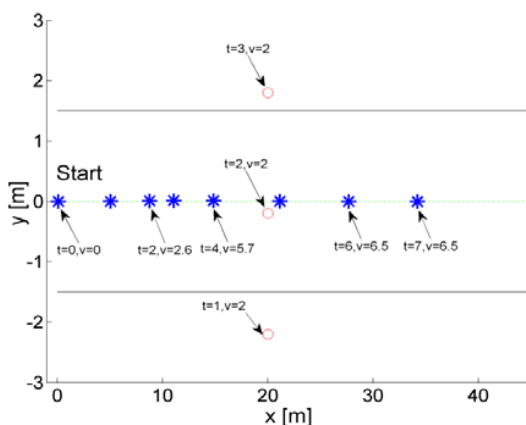

Fig. 12 Moving obstacle avoidance-Cyclist, pedestrian

V. CONCLUSION

Based on a single track vehicle model, the general hierarchical concept is presented. Based on a relevant path, an optimal control problem is solved by taking into account some constraints and boundaries such as road boundary and lateral and longitudinal acceleration. To make the optimal control easier to solve and make the system real-time capable, moving horizon approach is used by portioned the global problem into sub-problems. This feature permits to update the road situation in each increment which is critical in the case of obstacle or other vehicles on the lane. Due to the disturbances and uncertainty, it is necessary to build a closed loop path controller which generates additional inputs to decompensate errors.

A position based approach is presented to avoid the obstacle. The distance between the obstacle and vehicle is measured. Based on this distance a security region is created around the obstacle. If this region is exceeded, the obstacle avoidance penalty function will cost and makes the optimization algorithm to find a new solution which pass by the obstacle. The approach has been presented and confirmed by passing by single or multiple obstacles.

REFERENCES

- [1] D.Freidman, "The "RITE" Approach to Pedestrian and Cyclist Safety", April 2014, NHTSA.
- [2] Kelly,A.; Stentz,A. : Rough Terrain Autonomous Mobility-Part 1: Technical Analysis of Requirements In: Autonomous Robots 5 (1998), P.129-161.
- [3] Schmidt,S.; Kasper,R.: Bahnfolgeregelung für ein spurgeführtes Elektrofahrzeug, 6. Paderborner Workshop Entwurfmechatronischer Systeme, 2009, Paderborn, Germany.
- [4] Rieckert, P.; Schunk, A. : Zur Fahrndynamik des gummibereiften Kraftfahrzeuges, Ingenieur Archiv, 1940, Bd. XI, pp.210-244, Germany. R.Dariani, S.Schmidt, R.Kasper, " Real time optimization path planning strategy for an autonomous electric vehicle with obstacle avoidance ", FISITA 2014, The Netherlands.
- [5] S.Schmidt, R.Dariani, R.Kasper, " Echtzeitfähige Umsetzung eines Bahnplanungsverfahrens für autonome Fahrzeuge auf Basis der Optimalen Steuerung," 11.Magdeburger maschinenbau-Tage, 2013.
- [6] R.Dariani, S.Schmidt, R.Kasper, „Real Time Autonomous Driving Concept and experiment for a 4WD electric vehicle," 11.Magdeburger maschinenbau-Tage, 2013.
- [7] Khatib, O., "Real-Time Obstacle Avoidance for Manipulators and Mobile Robots." 1985 IEEE.International Conference on Robotics and Automation, St. Louis, Missouri, March 25-28, 1990, pp.500-505.
- [8] P. Fiorini,Z.Shiller "Motion planning in dynamic environments using velocity obstacles". The International Journal of Robotics Research. July 1998
- [9] R Glasius, A Komoda, "Neural network dynamics for path planning and obstacle avoidance".
- [10] Schittkowski, K.: NLPQLP: A Fortran Implementation of a Sequential Quadratic Programming Algorithm with Distributed and Non-Monotone Line Search - User's Guide, 2010,Version 3.1.