

Vehicle Position Estimation for Driver Assistance System

Hyun-Koo Kim, Sangmoon Lee, Ho-Youl Jung, and Ju H. Park

Abstract—We present a system that finds road boundaries and constructs the virtual lane based on fusion data from a laser and a monocular sensor, and detects forward vehicle position even in no lane markers or bad environmental conditions. When the road environment is dark or a lot of vehicles are parked on the both sides of the road, it is difficult to detect lane and road boundary. For this reason we use fusion of laser and vision sensor to extract road boundary to acquire three dimensional data. We use parabolic road model to calculate road boundaries which is based on vehicle and sensors state parameters and construct virtual lane. And then we distinguish vehicle position in each lane.

Keywords—Vehicle Detection, Adaboost, Haar-like Feature, Road Boundary Detection

I. INTRODUCTION

ADVANCED Driver Assistance Systems (ADAS) are systems which helps the driver in its driving process. When designed with a safe Human-Machine Interface it should increase car safety and more generally road safety. Robustness is of paramount importance when creating systems to be used in cars that are driving on public roads. The sensing and detection problems must be solved reliably. Fortunately, roads are designed to be: high contrast, predictable in layout and governed by simple rules. This makes the sensing problem easier, although by no means trivial. Additional sensors and algorithms can be used to reduce the probability of a catastrophic failure but robust systems require performance metrics and graceful failure modes built-in from the start.

Different road boundary and moving vehicle detection and tracking methods based on both active and passive sensors have been developed up to this time. Furthermore, it is already known that fusing data from two different sensors gives more robust results. In this paper a cooperative technique has been implemented in order to integrate information from active sensor such as laser scanner and from passive sensor like monocular camera.

In our proposed work we used fusion of laser and vision sensors. In order to calculate road boundaries and build virtual lane we used parabolic road model [1], [2]. We used Haar-like

Hyun-Koo Kim and Ho-Youl Jung are with Department of Information and Communication of Engineering, Yeungnam University, Kyongsan, South Korea (Emails: ilovecpp80@naver.com, hoyoul@yu.ac.kr).

Sangmoon Lee is with School of Electronics Engineering, Daegu University, Kyongsan, South Korea (Email: moony@daegu.ac.kr).

Ju H. Park is with Department of Electrical Engineering, Yeungnam University, Kyongsan, South Korea (Email: jessie@ynu.ac.kr).

feature detector [10], [11] and AdaBoost learning algorithm [12], [13] to detect vehicles. Finally, we distinguish vehicle position in each lane.

This paper is organized as follows: In Section II, we present the proposed road boundary and mid-lane detection methods. We discuss about the proposed vehicle detection method in section III. Finally, we show some results and conclude the paper in Section IV and V, respectively.

II. ROAD BOUNDARY AND MID-LINE DETECTION

In driver assistance system, it is important to distinguish between road parts and non-road parts. But, when the road environment is dark or a lot of vehicles are parked on the both sides of the road, it is difficult to detect lane and road boundary. So we propose a method to estimate road boundary using both camera and laser sensor.

A. Data Fusion of Camera and Laser Sensor

After getting data from camera and using Inverse Perspective Mapping (IPM) transformation technique, we remove perspective effects and then remapping each pixel toward a different position and producing a new two-dimensional array of pixels.

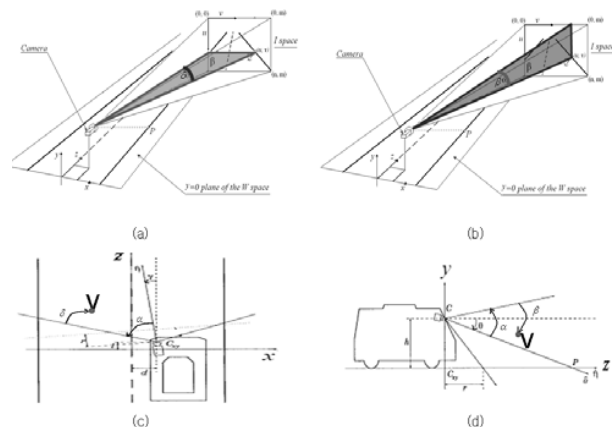

Fig. 1 Comparison of image space and world space. (a) Angle of v coordinates in the image space. (b) Angle of u coordinates in the image space. (c) A horizontal fixed angle of camera sensor. (d) A vertical fixed angle of camera sensor.

$$\frac{2\alpha}{m-1} = \frac{\delta}{v} \quad \therefore \delta = \frac{2\alpha v}{m-1} \quad (1)$$

$$\frac{2\alpha}{n-1} = \frac{\beta}{u} \quad \therefore \beta = \frac{2\alpha u}{n-1} \quad (2)$$

By using Eq (1) and (2), we obtain angle of u and v using a proportional expression. But when we calculate real angle (V_{rah} , V_{rav}) of object, we must consider camera aperture angle(α) and camera angular position (θ, γ). Angles of object (V) in the world space are given by Eq (3) and (4).

$$\begin{aligned} V_{rah} &= \gamma + \alpha - \delta \\ &= \gamma + \alpha - \frac{2\alpha v}{m-1} \end{aligned} \quad (3)$$

$$\begin{aligned} V_{rav} &= \theta - \alpha + \beta \\ &= \theta - \alpha + \frac{2\alpha u}{n-1} \end{aligned} \quad (4)$$

$$x = h \times \frac{\cos \left[(\gamma + \alpha) - v \frac{2\alpha}{m-1} \right]}{\tan \left[(\theta - \alpha) + u \frac{2\alpha}{n-1} \right]} + l,$$

$$z = h \times \frac{\sin \left[(\gamma + \alpha) - v \frac{2\alpha}{m-1} \right]}{\tan \left[(\theta - \alpha) + u \frac{2\alpha}{n-1} \right]} + d,$$

$$y = 0 \quad (5)$$

By using Eq (5), we obtain coordinates of world space angle.

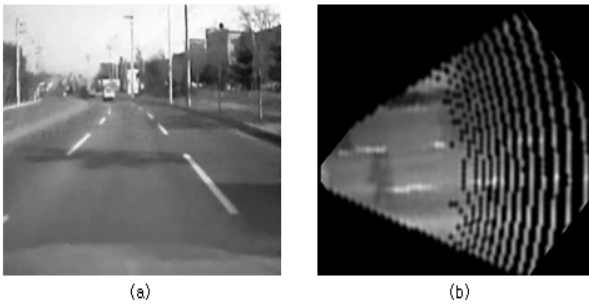

Fig. 2 Inverse Perspective Mapping.

(a) Captured camera image. (b) Inverse perspective mapping image.

Then we integrate the information from 3D Laser scanner and result from CCD Camera image.

B. A simple parabolic road model

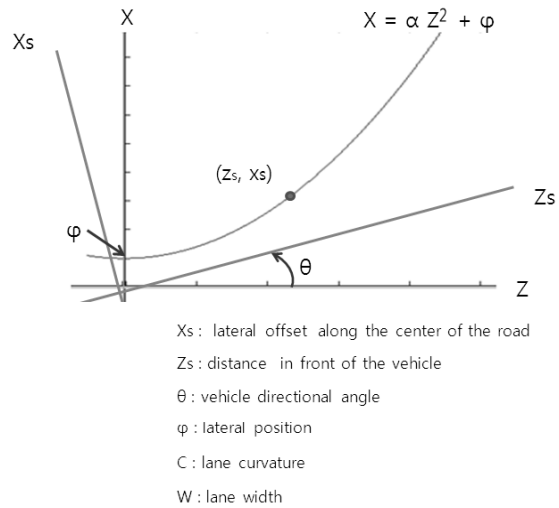

Fig. 3 A simple parabolic road model.

Using simple parabolic road model [3]-[5], we can find road boundaries from three dimensional fusions data. Knowing state parameters of the vehicle, like vehicle directional angle, lateral position, distance in front of the vehicle (fusion data from Laser scanner and IPM) and some road information like lane width and Camera position (camera angular position, optical axis information and camera resolution). Comparing these data and using our road model we can calculate the virtual lane.

If the center of the vehicle is (Z, X) and by rotating the coordinate by (in fig. 3), we can calculate X_s

$$\begin{bmatrix} Z \\ X \end{bmatrix} = \begin{bmatrix} \cos(\theta) & -\sin(\theta) \\ \sin(\theta) & \cos(\theta) \end{bmatrix} \begin{bmatrix} Z_s \\ X_s \end{bmatrix}$$

if $|\theta| \ll 1$ then

$$\begin{bmatrix} Z \\ X \end{bmatrix} = \begin{bmatrix} 1 & -\theta \\ \theta & 1 \end{bmatrix} \begin{bmatrix} Z_s \\ X_s \end{bmatrix} = \begin{bmatrix} Z_s - \theta X_s \\ \theta Z_s + X_s \end{bmatrix}$$

Input $X = \alpha Z^2 + \phi$

$$\theta Z_s + X_s = \alpha (Z_s - \theta X_s)^2 + \phi$$

if $(\theta \ll 1)$ then

$$\theta Z_s + X_s \approx \alpha Z_s^2 + \phi$$

$$X_s = \alpha Z_s^2 - \theta Z_s + \phi \quad (6)$$

By using curvature equation and Eq(6) we obtain Eq (7)

$$C_{z=0} = \frac{2 \times \alpha}{(1 + 2 \times \alpha \times 0)^{\frac{3}{2}}} = 2 \alpha = C$$

$$\alpha = \frac{C}{2}$$

if $(\theta \ll 1)$ then

$$Xs = \frac{C}{2} Zs^2 - \theta Zs + \phi \quad (7)$$

C. Road boundary Detection

An important characteristic of typical road is, it is made up of road surface, curb, and pavement surface (See Fig. 4), and typically, road surface is flat but pavement surface is higher than the road surface. Road marks are clearly painted on the flat surface of the road. The features just make extraction possible by using color and shape of our rendered laser point cloud [6].

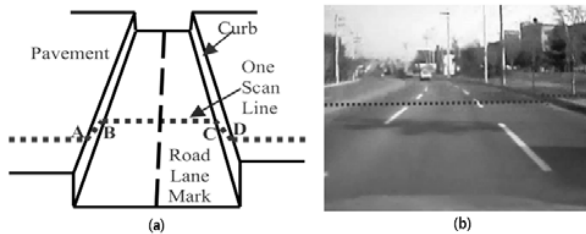

Fig. 4 (a) Typical Road Model. (b) Corresponding Laser Point Cloud.

The Road lane mark detection is based on rendered 3D laser point cloud, which is fused data from camera image and laser range data. These seamless rendered laser point cloud data make detection processing easy and robust. In the processing, the first step is lane point detection by color information of laser scan line.

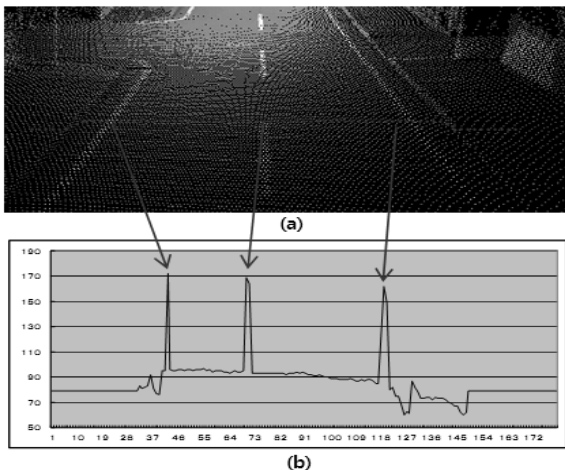

Fig. 5 Light Distribution along One Scan Line.

(a) One scan line in 3D laser point cloud.

(b) Three peaks in light distribution along the scan line.

From Fig.5, the lane point can be easily done using light distribution. Fig.5 (b) shows that there are three peaks in light distribution along the scan line, which denotes that three mark points exist in the scan line (horizontal axis is angle number of laser point along scan line; Vertical axis is gray of laser point along scan line). Like such processing, mark points are being detected line by line.

D. Mid-line Detection

By using elements of road boundary and lane mark and Lagrange polynomial Interpolation, we calculated mid-line. Given a set of 3 data, Lagrange polynomial equation:

data: $(x_1, y_1), (x_2, y_2), (x_3, y_3)$

$$f(x) = \sum_{j=1}^3 (y_j \times \prod_{i=1, i \neq j}^3 \frac{x - x_i}{x_j - x_i})$$

$$= y_1 \frac{(x - x_2)(x - x_3)}{(x_1 - x_2)(x_1 - x_3)} + y_2 \frac{(x - x_1)(x - x_3)}{(x_2 - x_1)(x_2 - x_3)} + y_3 \frac{(x - x_1)(x - x_2)}{(x_3 - x_1)(x_3 - x_2)}$$

$$f(x) = \frac{y_1(x_2 - x_3) + y_2(x_3 - x_1) + y_3(x_1 - x_2)}{(x_1 - x_2)(x_1 - x_3)(x_2 - x_3)} x^2 - \frac{y_1(x_2^2 - x_3^2) + y_2(x_3^2 - x_1^2) + y_3(x_1^2 - x_2^2)}{(x_1 - x_2)(x_1 - x_3)(x_2 - x_3)} x + \frac{y_1 x_2 x_3 (x_2 - x_3) + y_2 x_3 x_1 (x_3 - x_1) + y_3 x_1 x_2 (x_1 - x_2)}{(x_1 - x_2)(x_1 - x_3)(x_2 - x_3)} \quad (8)$$

By Eq (7) and using (8), we obtain C, θ, Φ .

$$C = 2 \times \left(\frac{y_1(x_2 - x_3) + y_2(x_3 - x_1) + y_3(x_1 - x_2)}{(x_1 - x_2)(x_1 - x_3)(x_2 - x_3)} \right)$$

$$\theta = \frac{y_1(x_2^2 - x_3^2) + y_2(x_3^2 - x_1^2) + y_3(x_1^2 - x_2^2)}{(x_1 - x_2)(x_1 - x_3)(x_2 - x_3)}$$

$$\phi = \frac{y_1 x_2 x_3 (x_2 - x_3) + y_2 x_3 x_1 (x_3 - x_1) + y_3 x_1 x_2 (x_1 - x_2)}{(x_1 - x_2)(x_1 - x_3)(x_2 - x_3)} \quad (9)$$

As a result, we obtain mid-line polynomial. Fig.6 shows that mid-line detection in the road boundary using camera and laser sensor.



Fig. 6 Mid-line detection of road boundary.

III. VEHICLE DETECTION

A. Harr-like feature

A simple rectangular Haar-like feature can be defined as the difference of the sum of pixels of areas inside the rectangle, which can be at any position and scale within the original image. This modified feature set is called 2 rectangle features. Viola and Jones also defined 3 and 4 rectangle features [7]. These values indicate certain characteristics of a particular area of the image. Each feature type can indicate the existence (or not) of certain characteristics in the image, such as edges or changes in texture. For example, a 2 rectangle feature can indicate where lies the border between a dark region and a light region.



Fig. 7 Feature prototypes of simple Haar-like. Black areas have negative and white areas positive weights .

The simple features used are reminiscent of Haar basis functions which have been used by Papageorgiou et al. [8]. Moreover, we used three types of feature. The value of a *two-rectangle feature* is the difference between the sums of the pixels with two rectangular regions. The regions have the same size and shape and horizontally or vertically neighbouring (Fig. 7). A *three-rectangle feature* calculates the sum within two outside rectangles subtracted from the sum in a center rectangle. Finally a *four-rectangle feature* computes the difference between diagonal pairs of rectangles. Given that the base resolution of the detector is 24 x 24, the exhaustive set of rectangle features is quite large, over 170,000. Note that unlike the Haar basis, the set of rectangle features is overcomplete.

Denote the feature set as $F = \{f_i | i = 1, \dots, N\}$ and corresponding feature values on images observation z as:

$$V(z) = v_i(z) | i = 1, \dots, N.$$

The numbers of features even in a 24 x 24 image patch are so big to compute every time. Nevertheless, we can calculate them if we have a gathered sum of intensity from origin:

$$S_{acc}(i, j) = \sum_{x=0}^i \sum_{y=0}^j I(i, j) \quad (15)$$

If a rectangle is defined by the region $[x_{left}, x_{right}] \times [y_{up}, y_{down}]$, the sum of intensity in the rectangle is following:

$$S_{acc}(x_{right}, y_{down}) - S_{acc}(x_{left}, y_{down}) - S_{acc}(x_{right}, y_{up}) + S_{acc}(x_{left}, y_{up}) \quad (16)$$

B. Adaboost Algorithm

Given set of features and a training set of positive (vehicle) and negative (non-vehicle) sample images, any number of

machine learning approaches could be used to learn a classification function. A variant of AdaBoost is used for selecting a small set of features and training the classifier [9]. The AdaBoost learning algorithm is used to boost the classification performance of a simple (sometimes called “weak”) learning algorithm. We have to keep in mind that, there are over 170,000 rectangle features associated with each image 24x24 sub-window, a number far larger than the number of pixels. Although each feature can be computed very efficiently, the computation of the complete set is unrealizable. Here, the main goal is to find a very small number of these features that might be combined to form an effective classifier. To support this purpose, the “weak” learning algorithm is designed to select the single feature which best separates the positive and negative examples. For each feature, the weak learner determines the optimal threshold classification function, so that the minimum number of examples are misclassified.

A weak classifier $h_j(x)$ consists of a feature f_j , a threshold θ_j and a likeness p_j indicating the direction of the inequality sign. In Eq. (17) the value 1 represents a vehicle and 0 represents a non-vehicle. Every classifier are not able to detect a vehicle. Rather, it reacts to some simple feature in the image that may be related to the vehicle:

$$h_j(x) = \begin{cases} 1 & p_j f_i < p_j \theta_j \\ 0 & otherwise \end{cases} \quad (17)$$

An extended presentation of the boosting process is described by Viola et Al [10].

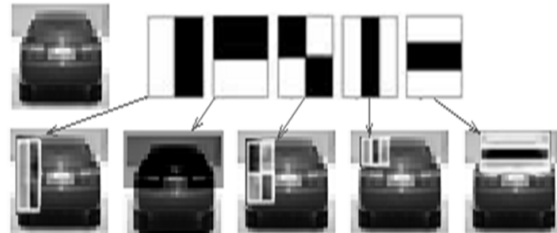

Fig. 9 Top: vehicle-like image region and basic forms of the Haar filters. Bottom: application of filters derived from the basic ones at particular pixels where the filters give a high magnitude response.



Fig. 10 Same directional vehicle detection of using haar-like and adaboost.

C. Vehicle Position

Using parabolic road model, we distinguish another vehicle position in the each lane. If Eq. (7) is mid-line of the road, we obtain each lane boundary equations of the road.

If R : width of all road.

W : width of one road.

$2N$: the number of road lane.

$$L = \begin{pmatrix} +1 : \text{same direction lane} \\ -1 : \text{opposite direction lane} \end{pmatrix}$$

N : the number of one directional road

$$N = \left\lfloor \frac{R}{2W} \right\rfloor \tag{18}$$

Virtual lane boundary of n -times as:

$$\begin{aligned} X_{nB}(Z_S) &= X_S + \frac{nWL}{\sqrt{(CZ_S - \theta)^2 + 1}} \\ Z_{nB}(Z_S) &= Z_S - \frac{nWL(CZ_S - \theta)}{\sqrt{(CZ_S - \theta)^2 + 1}} \end{aligned} \tag{19}$$

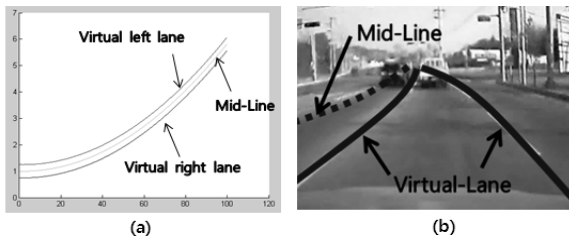

Fig. 11 Calculate and construct of virtual lane and mid-line.

And if we know another vehicle position (Z_{sv}, X_{sv}), we can obtain distance between another vehicle and mid-lane.

$$d = 2 \times \frac{\frac{1}{C} \left(\left(\frac{X_{sv} - \phi}{Z_{sv}} \right)^2 - \theta^2 \right) + \phi}{\sqrt{\left(\frac{X_{sv} - \phi}{Z_{sv}} \right)^2 + 1}} \tag{20}$$

And we obtain the number lane of another vehicle position. That is:

$$L_v = \left\lfloor \frac{d}{W} \right\rfloor \tag{21}$$



Fig. 12 Distinction of vehicle position. (a) Vehicle detection of both directions. (b) Vehicle detection of same direction.

IV. RESULTS AND CONCLUSIONS

By remapping fusion data obtained from 3D Laser scanner and result from CCD Camera image and using simple parabolic road model, we have got mid-lane of road boundary. Then we detected vehicles in two directions with Haar-like feature detector. In the next stage we calculated the lane position of detected vehicles. For real time processing, we made Learning data by normalized train data with size of 24 x 24 (pixel). At that time, we use 200 sets of vehicle, 700 sets of non-vehicle and 162336 features of Haar-like.

In our experiment we used Laser scanner LMS 291 of SICK Sensor Intelligence Company with 180° scanning angle and 38400 bps. Resolution of the camera data is 640*480, 15 fps in the Pentium Dual CPU 2.2 GHz. And, in the same direction, we achieved the 90.63% of accuracy. In the opposite direction, we obtained the 85.20% of accuracy.

In the future we want to improve our system by tracking the vehicle position using Kalman filter and improve an accuracy of opposite vehicle detection.

ACKNOWLEDGMENT

This work of H.K. Kim was supported by the Korea Student Aid Foundation (KOSAF) grant funded by the Korea Government (MEST) (No. S2-2009-000-00949-1). The research of J.H. Park was supported by the Yeungnam University research Grant (209-A-380-120) in 2009.

REFERENCES

- [1] JC McCall, MM Trivedi, "Video-based lane estimation and tracking for driver assistance: survey, system, and evaluation", IEEE transactions on intelligent transportation systems, Vol. 7, pp. 20, 2006.
- [2] Wang, C. Hu, Z. Uchimura, K. "Precise curvature estimation by cooperating with digital road map", IEEE Intelligent Vehicles Symposium, pp. 859-864, 2008.
- [3] Camillo J. Taylor . "A Comparative Study of Vision-Based Lateral Control Strategies for Autonomous Highway Driving", The International Journal of Robotics Research, Vol. 18, No. 5, 442-453, 1999.
- [4] Goldbeck, J. Huertgen, B. "Lane detection and tracking by video sensors", Intelligent Transportation Systems, pp. 74-79, 1999.
- [5] Bertozzi, M. Broggi, A. "GOLD: a parallel real-time stereo vision system for generic obstacle and lane detection", IEEE Transactions on Image Processing, Vol. 7, pp. 62-81, 1998.
- [6] W.S. Wijesoma, K. R. S. Kodagoda., A. P. Balasuraya, and E. K. Teoh. "Laser and camera for road edge and midline detection", Robot Motion and Control, 2001 Proceedings of the Second International Workshop, 269-274, October, 2001.
- [7] Viola and Jones, "Rapid object detection using boosted cascade of simple features", Computer Vision and Pattern Recognition, 2001.
- [8] C. Papageorgiou, M. Oren, and T. Poggio. A general framework for object detection. In International Conference on Computer Vision, 1998.
- [9] Y.Freund and R. E. Schapire. "A decisiontheoretic generalization of on-line learning and an application to boosting." In European Conference on Computational Learning Theory, 1995.