

Nonlinear Fuzzy Tracking Real-time-based Control of Drying Parameters

Marco Soares dos Santos, Camila Nicola Boeri, Jorge Augusto Ferreira and Fernando Neto da Silva

Abstract—The highly nonlinear characteristics of drying processes have prompted researchers to seek new nonlinear control solutions. However, the relation between the implementation complexity, on-line processing complexity, reliability control structure and controller's performance is not well established. The present paper proposes high performance nonlinear fuzzy controllers for a real-time operation of a drying machine, being developed under a consistent match between those issues. A PCI-6025E data acquisition device from National Instruments® was used, and the control system was fully designed with MATLAB® / SIMULINK language. Drying parameters, namely relative humidity and temperature, were controlled through MIMO's Hybrid Bang-bang+PI (BPI) and Four-dimensional Fuzzy Logic (FLC) real-time-based controllers to perform drying tests on biological materials. The performance of the drying strategies was compared through several criteria, which are reported without controllers' retuning. Controllers' performance analysis has showed much better performance of FLC than BPI controller. The absolute errors were lower than 8,85 % for Fuzzy Logic Controller, about three times lower than the experimental results with BPI control.

Keywords—Drying control, Fuzzy logic control, Intelligent temperature-humidity control.

I. INTRODUCTION

D RYING technology is a major energy consumer in many industries, including agriculture, biotechnology, food, textile, mineral, pharmaceutical, pulp and paper, polymer, wood, and others. Dufour suggests that drying is also the oldest chemical engineering unit operation [1]. Drying of biological products has been done traditionally taking advantage of the places where the climate makes it feasible. However, the process of successful natural drying depends upon actual meteorological conditions, is a intensive labour activity and lasts for too long. The wide variety of products available today demands high quality specifications. The need

to optimize energy utilization during drying leads to the development of control strategies for the drying plants. In general, material moisture content is the crucial process variable affecting both energy conservation efficiency and final product quality [2]. For high-quality, high-efficiency, and low energy consumption, human decision-based systems have been replaced by *artificial* control systems. Drying control is very complex given its highly nonlinear dynamic: its variables are strongly coupled and lagged [3], namely in what concerns external factors such as temperature, air humidity and air velocity; additional factors such as time, slow dynamics, non-minimum phase, high order, hidden time-constants in high frequencies, nature of feeding, gas-solid contact mode, how energy is introduced into the system, among others affect the rate drying. This is the main reason why it is difficult to develop an accurate drying model, particularly when biological materials, with unique sample characteristics are concerned. Together with pneumatic control systems [4], drying control is a research field that drives the control techniques' evolution, and it is possible to say that the drying systems' evolution is strongly linked to control techniques' evolution. Many attempts on temperature and humidity control of drying process were and are yet conducted. Drying process parameters are full of uncertainties due to complexity of transfer laws. In complex plants, namely in drying technology, it is often impossible to formulate a physicochemical model of the process [5], because they should include the nonlinear characteristics, including heat and mass transfer phenomena, generally characterized by a complex transfer mechanism of mass and energy. Drying control algorithms designs assuming "perfect" models is an expensive mistake, because all the conclusions are as accurate as the model that they were developed from [6]. «The solution [...] was based on the assumption of perfect models being available. In practice, the best that can be expected is that the drying [...] models are a reasonable approximation to reality, in which case some form of feedback must be introduced», refers Musch *et al* [7]. «The thermodynamic modeling and control has been a subject of extensive research. Most of the automatic control schemes of grain drying process for industrial application are based on conventional control methods. The drying process is highly complex, nonlinear,

The present work was conducted with the support of the FCT - Foundation for Science and Technology, through PhD scholarship.

M. P. Soares dos Santos is with the Department of Mechanical Engineering of University of Aveiro, Aveiro (corresponding author to provide phone: (+351) 234370830; fax: (+351) 234370953; e-mail: marco.santos@ua.pt)

C. N. Boeri is with the Department of Mechanical Engineering of University of Aveiro, Aveiro (phone: (+351) 234370830; fax: (+351)234370953; e-mail: camilaboeri@ua.pt).

J. A. F. Ferreira is with the Department of Mechanical Engineering of University of Aveiro, Aveiro (phone: (+351) 234370830; fax: (+351) 234370953; e-mail: jaff@ua.pt)

F. J. Neto da Silva is with the Department of Mechanical Engineering of University of Aveiro, Aveiro (phone: (+351) 234370830; fax: (+351) 234370953; e-mail: fneto@ua.pt)

and long time delay, but many conventional control design procedures require restrictive assumptions for the drying process (e.g., linearity)», is said by Liu *et al* [8].

The strong influence of over-drying on the final quality underlines the need for a high performance control of the dryer. Liu and Bakker-Arkema [9] recognized that some commercial driers controllers are being marketed with primitive processes models and control algorithms. «Most of the automatic dryer control schemes for industrial applications are based on empirical relationships and conventional control methods. Due to lack of robustness and proper modeling techniques, these controller performances are not found satisfactory. Hence, there is a need felt to design and synthesize appropriate intelligent control strategy», was written by Thyagarajan [10]. Abukhalifeh, Dhib and Fayed [11] have said that the development and implementation of good controllers to operate industrial dryers with high efficiency has not been reached. Hence, they believe that the development of good control strategies is still far away of the satisfactory stage.

Usually, the general problems found in related papers are: (1) some articles presented a very small set of experimental results, hence cannot be constituted as conclusive evidences of the control system performance; (2) some of the papers did not describe which method was used to find the controller parameters; (3) the design of the control surface from the optimal correlation between the all drying parameters was not always described; (4) the intensive use of the PID method even in the development of hybrid controllers; (5) the controller performance analysis was sometimes missing; (6) and the controller(s) design was not always quite clarified.

The model-based predictive control (MPC) is a control scheme that «aims to predict the future behavior of the process and the best behavior is chosen by a correct tuning of the manipulated variables» [1]. This strategy is one of the most used techniques in advanced drying control. In fact, it is advantageous to take benefits from its prediction ability, because solving an explicit optimization problem formulated into the future has shown to be appropriate specially one has to deal with very slow dynamics, time dependency, accentuated nonlinearity and interdependence of drying parameters. Kokko, Lautala and Huhtelin [12] proposed a multivariable MPC to control an impingement dryer of a high-speed paper machine. Dufour *et al* [13] designed a model predictive controller for experimental water painting that uses a diffusional model leading to the knowledge of the drying characteristics, which is first processed off-line. Schuster and Kozek [14] developed a mathematical model of an industrial drying process for viscose staples fibers, which allowed the introduction of two MPC schemes for state-space models. Yüzgeç, Becerikli and Türker [15] presented a neural-network-based MPC scheme for a baker's yeast drying process. Genetic-based search algorithm were used to find the optimal drying profile by solving optimization problem in MPC. A minimum realization linear model used to develop a MPC is considered by Abukhalifeh, Dhib and M.Fayed [16]. Slätteke [17] implemented an MPC controller for moisture

content control in paper production, through the object-oriented modeling language Modelica. Taira [18] presented a new control scheme called «Mathematical programming type model predictive receding horizon control method», which allowed the control of the temperature and humidity simultaneously with minimizing energy consumption. An adaptive control algorithm GPC (Generalized Predictive Control) to the control of egg drying in a spouted bed dryer was tested by Corrêa *et al* [19].

The study of Gou *et al* [5] concerned the application of two FLC P (each one to different batches) to control the relative humidity of fermented sausages drying, through 29 fuzzy rules. They starting their propose saying that it is often impossible to get an accurate model in complex drying technology, showing FLC as «ideal for modeling and controlling complex». Alvarez-López, Llanes-Santiago and Verdegay [20] designed a relative humidity's fuzzy controller for drying of tobacco leaves. With error and the change error as their inputs and 49 rules, the controller's performance seems to provide better results than «the already established control algorithms», presenting relative humidity errors in the neighbour of null error. Athajariyakul and Leephakpreeda [21] found a systematic determination of optimal conditions for fluidized bed paddy drying, and then put forward an adaptive FLC to obtain improved quality and increase energy efficiency. The drying air temperature and the percent of recycle air are controlled through only 6 rules, designed from the drying air temperature and percent of the recycle air errors. A learning algorithm was introduced along a gradient descent-based optimization to adapt the FLC parameters. The sensitivity learning rule adjusts the fuzzy variables' sets. Experimental and simulated results showed a good controller's performance: a moisture content error lower than 2.5% was achieved. Wang *et al.* [22] build up an indirect fuzzy adaptive controller for wood drying which combines an adaptive control based on local drying dynamics and intelligence reflecting process dynamics relating species, size and others conditions of lumber. They have divided it into two sub-systems: a moisture adaptive control sub-system and a temperature adaptive control sub-system, although the authors do not clarify adaptive laws and the parameter estimation. Both simulated and experimental results show maximum deviation lower than 0,4 % of the average moisture. Discuss that FLC is particularly suitable for complex systems and ill-defined processes which analytical modeling is difficult and the available information is incomplete. Azadeh, Neshat and Saberi [23] built an approach based on adaptive Neuro-Fuzzy Inference Systems (ANFIS), Artificial Neural Network and Partial Least Squares (PLS) analysis to get better predictive control of a spray drying process. They proposed an integrated algorithm PLS-ANN-ANFIS that deals reliably with complexity, nonlinearity and noise on modeling complex and nonlinear processes. Both ANN and ANFIS approaches are applied for granule particle size prediction and was it proved the performance enhancement of PLS-ANFIS model in relation with the PLS-ANN model. Zhu, Wang and Qian [3]

devoted themselves to develop a fuzzy immune PID controller to control the temperature and humidity of drying processes. They used off-line parameters' optimization by least square algorithm and on-line optimization through genetic algorithm. Fuzzy immune PID controller consists of fuzzy reasoning, immune adjust and fuzzy PID control. Based on above immune feedback principle of biology system, the immune feedback mechanism is applied into PID control and the temperature and humidity is controlled using fuzzy immune PID algorithm. The temperature fuzzy PID controller was designed with the temperature error and its change as inputs, while the humidity fuzzy PID controller waits for the humidity and its change as inputs. Simulated results with 49 rules have confirmed that both temperature and relative humidity were better controlled with fuzzy immune PID than classic fuzzy PID or simple PID approaches. Zhang, Shi and Ling [24] put forward a fuzzy PID controller, on the whole a FLC P+PID controller, to a process of milk powder spray-drying. Assuming the temperature error and its change as inputs, and 49 rules, the simulation results have shown the ability of this controller to handle non-linear factors. Sun, Li and Cao [25] put forward a control scheme for a microwave-vacuum wood drying that performs a switch between a two-dimensional fuzzy self-tuning PID controller and a digital PID controller. Thyagarajan et al. [26] made a comparison between PID, FLC, FLC using Genetic Algorithms (FLC-GA) and Neuro Fuzzy Control (NFC) when is required the air heat plant control. The integral of the error is used as a fuzzy input. The performance analysis has proved the advantage of FLC over PID, FLC-GA over FLC and NFC over other schemes. Guo, Cao and Zheng [27] detailed the fuzzy design of an intelligent temperature and humidity controller of an air conditioning control system used in industrial workshops and buildings. They use a three rules set: the first one to customize tracking operation to meet the working conditions; the second one to select the control method; the third was suited for on-off control. Becker et al. [28] tested an FLC to control the temperature and humidity for refrigeration systems. After surveying the relation between the temperature and the relative humidity after disturbances and changes of cooling or fan power, the fuzzy temperature controller was designed with temperature error and change temperature error as inputs and 25 rules, whereas the fuzzy humidity temperature controller counts with the temperature error, humidity error and humidity error change and 45 rules. Simulated results have shown good dynamic process behavior after changes of set points and under the influence of disturbances. Nachidi, Benzaouia and Tadeo [29] proposed a Talagi-Sugeno (T-S) fuzzy model from a simplified dynamic model of the greenhouse climate. Together with a parallel distributed compensation (PDC), they achieved the required climate conditions, which point the T-S approach as appropriated for very complex process with high nonlinearity such as a greenhouse climate.

II. MECHANICAL APPARATUS

The used drying machine has been used for codfish drying [30]-[31], although it can be used to dry any kind of products within its technical specifications. Figure 1 shows the drying machine's mechanical apparatus and instrumentation. It includes a centrifugal blower, driven by a variable velocity AC motor which defines the air velocity control within the drying chamber. The air is forced through electric heating resistances allowing the air temperature to be raised. Steam at atmospheric pressure is used for humidification and a cooler/dehumidifier is used for cooling and dehumidifying the drying air. The air velocity is measured by a Pitot tube and micro-manometer (Furness, model FC0510). The air temperature and the relative humidity are acquired through a digital thermo-hygrometer (Omega, model RH411), with temperature accuracy of $\pm 1^\circ\text{C}$ in the range -18°C to 49°C , and humidity accuracy about $\pm 5\%$ at 25°C in the range 5%-20%, $\pm 3\%$ at 25°C between 20%-90%, and $\pm 5\%$ at 25°C between 90%-99%. Figure 2 concerns about the schematic design of the dryer where all codfish drying tests were performed.

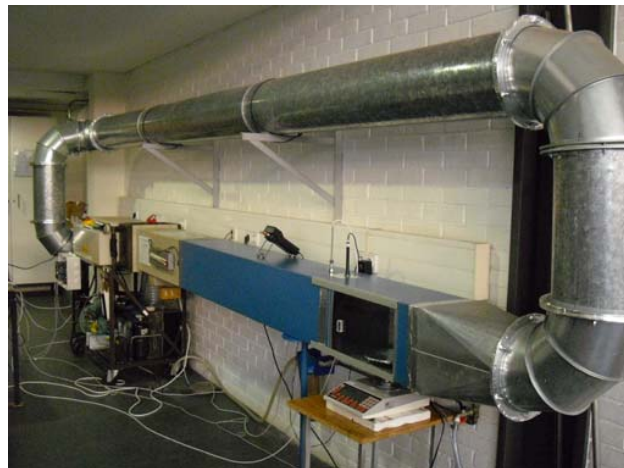

Fig. 1 Drying Machine

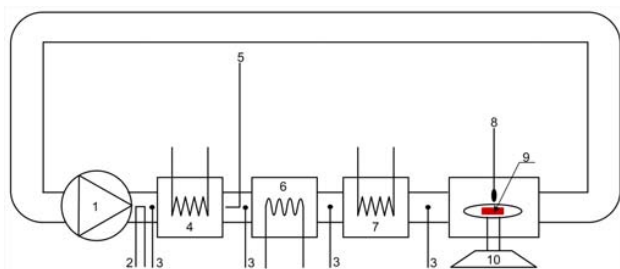

Fig. 2 Dryer schema of the drying machine

(1 – centrifugal blower; 2 – humidifier; 3 – temperature sensors; 4 – electrical resistances of 2 kW; 5 – pitot tube and micro-manometer; 6 – dehumidifier; 7 – electrical resistances of 1 kW; 8 – thermo-hygrometer; 9 – sample; 10 – digital balance).

III. HARDWARE PLATFORM

The control and operation of the drying process are accomplished by a computer card in conjunction with the Matlab/Simulink® platform. Data acquisition of the dryer is handled by a PCI-6025E card, from National Instruments. It has 12 bits analog outputs and 12 bits analog inputs, with sampling rates of 20 kS/s and 200kS/s, respectively. From its eight analog inputs, four of them were used to acquire the ambient temperature, and the current temperature, relative humidity and air velocity within the dryer. The two analog outputs were used for output of the dehumidifier and centrifugal blower signals. Despite their 32 digital I/O ports, only four were employed to send the electrical and humidifier resistances control signals. The PC is a Pentium dual core CPU of 2.25 GHz and 2 GB of RAM. The hardware platform scheme is represented in Figure 3.

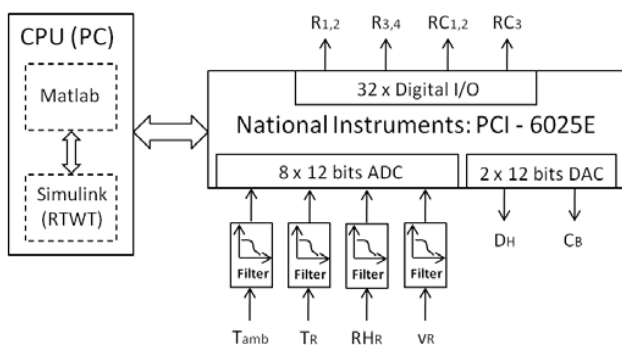

Fig. 3 Hardware platform.

($R_{1,2}$ – Electrical Resistances 1 and 2 of 2 kW each; $R_{3,4}$ – Electrical Resistances 3 and 4 of 1kW each; $RC_{1,2}$ – Humidifier Resistances 1 and 2 of 2kW each; RC_3 – Humidifier Resistance 3 of 1kW; T_{amb} – Ambient Temperature; T_R – Current temperature; RH_R – Current relative humidity; v_R – current velocity; D_H – Dehumidifier; C_B – Centrifugal blower).

IV. SOFTWARE PLATFORM

The control, operating and monitoring software was designed in the Matlab/Simulink® environment. With the Real-Time Windows Target, it was possible to run Simulink program in real-time on the PC, with 10ms deadline. Using Real-Time Workshop (RTW) 7.3 from Mathworks, C code was generated, compiled and put into real-time execution on the Windows-based PC [32]. This connection is established with the Simulink external mode, which allows that RTW can load the customized program into memory. This RTW target I/O device drivers support the building of an interface between the monitoring and control software and the instrumentation devices, performed through the PCI-6025E board. All acquisition operations were done through the Data Acquisition Toolbox from Matlab. Hence, a PC-in-the-loop prototyping was developed with the requirements of high speed deterministic control, an easy interface due to its ability to interface all the sensors and actuators of the drying machine, and the easy controllers' upgrade. Figure 4 shows the platform software to control the drying processes.

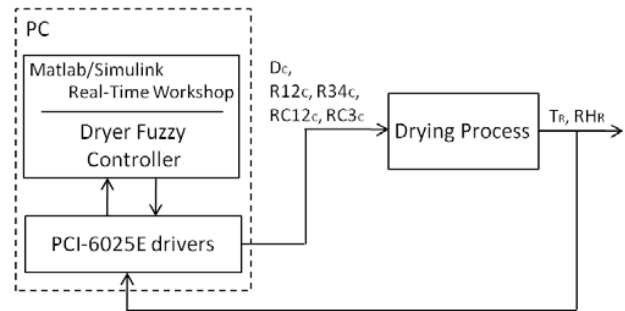

Fig. 4 Software platform in the drying process.

(D_C – Dehumidifier control signal; R_{12_C} – Electrical Resistances 1 and 2 control signal; R_{34_C} – Electrical Resistances 3 and 4 control signal; RC_{12_C} – Humidifier Resistances 1 and 2 control signal; RC_{3_C} – Humidifier Resistances 3 control signal; T_R – Current temperature; RH_R – Current relative humidity).

V. DRYING PROCESS DYNAMICS

A. Operation Conditions

Drying tests were performed for the following operational conditions: air temperature: [15 23] (°C); air velocity: [1.5 2.5] (m/s); relative humidity: [40 70] (%).

Air temperature values should be around 20°C. Values above 20°C-22°C will compromise the dried codfish final quality. The constraints of the mechanical apparatus have limited the relative humidity's to values above 45%. The air velocity's values stayed in the range used for the fish drying [33]-[36].

B. Open-loop Experiments

To find the best control scheme always implies the knowledge of the dynamics of drying machine: a survey highlighted factors such as slowness of the process, its time dependency, its nonlinearity, the interdependence of drying parameters and the influence of the control signal change in the dynamics behavior of temperature, relative humidity and velocity. This fundamental knowledge is required to build up either numerical or experience based controllers. These nonlinearities were studied through a set of experimental procedures, namely by: (1) D_C changing in a ramp function while $R_{12,34_C}$ and $RC_{12,3_C}$ were kept down; (2) D_C changing in several steps, while $R_{12,34_C}$ and $RC_{12,3_C}$ were kept down; (3) $RC_{12,3_C}$ changing in several steps, while $R_{12,34_C}$ and D_C were kept down; (4) $R_{12,34_C}$ changing in several steps, while D_C and $RC_{12,3_C}$ were kept down; (5) D_C and $RC_{12,3_C}$ changing in steps while $R_{12,34_C}$ were kept down; (6) D_C and $R_{12,34_C}$ changing in steps while $RC_{12,3_C}$ were kept down; (7) $R_{12,34_C}$ and $RC_{12,3_C}$ changing in steps and while D_C were kept down; (8) $RC_{12,3_C}$, $R_{12,34_C}$ and D_C changing in steps.

Figures 5 to 16 illustrate this set of open loop experiments. Two initial operating points were defined: (1) $T_R \approx 24^\circ\text{C}$ and $RH_R \approx 96\%$; (2) $T_R \approx 49^\circ\text{C}$ and $RH_R \approx 10\%$. Should be noted that the dehumidifier and the centrifugal blower were kept at about 50% of its maximum capacity when they were not being controlled (in which case they are kept constant).

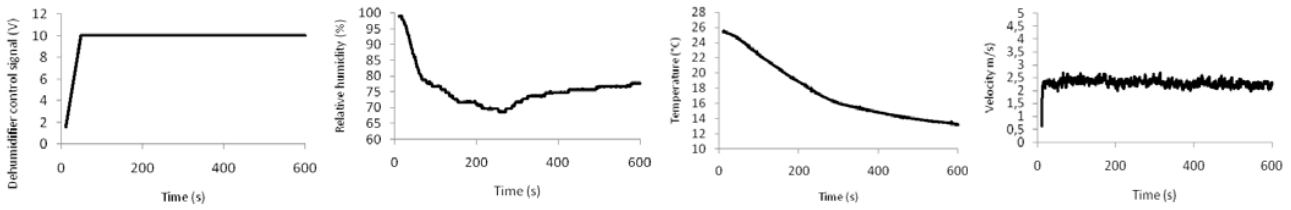

Fig. 5 Dynamics of drying process parameters when the dehumidifier control signal is changed.

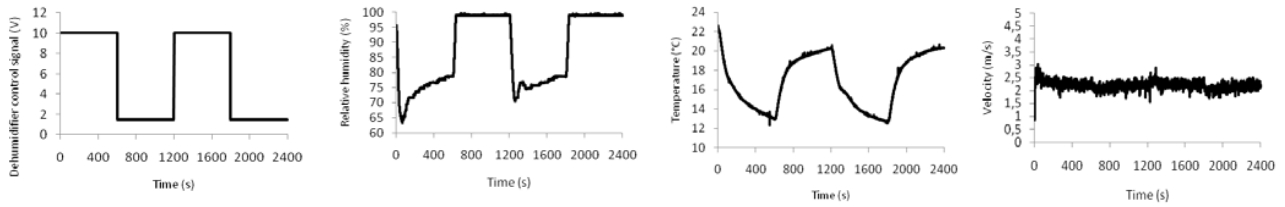

Fig. 6 Dynamics of drying process parameters when dehumidifier control signal is changed.

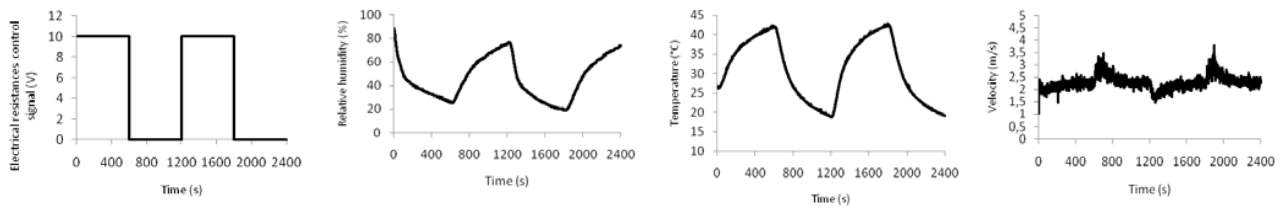

Fig. 7 Dynamics of drying process parameters when electrical resistances control signal is changed.

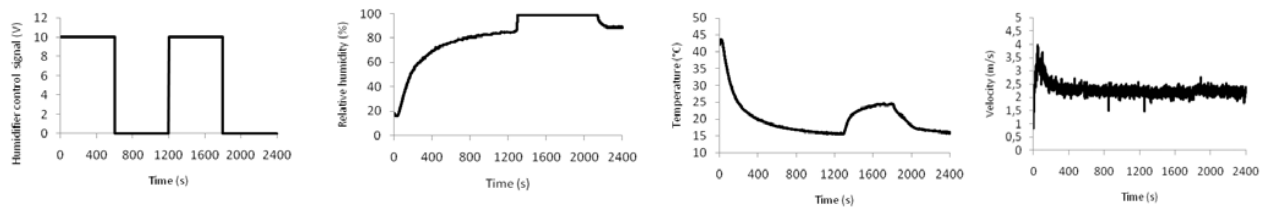

Fig. 8 Dynamics of drying process parameters when humidifier control signal is changed.

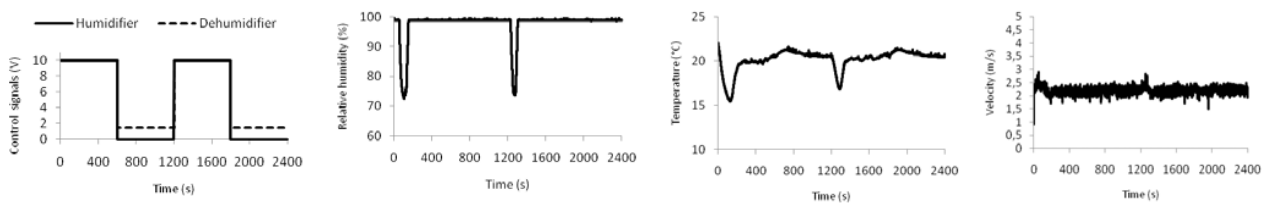

Fig. 9 Dynamics of drying process parameters when dehumidifier and humidifier control signals are changed.

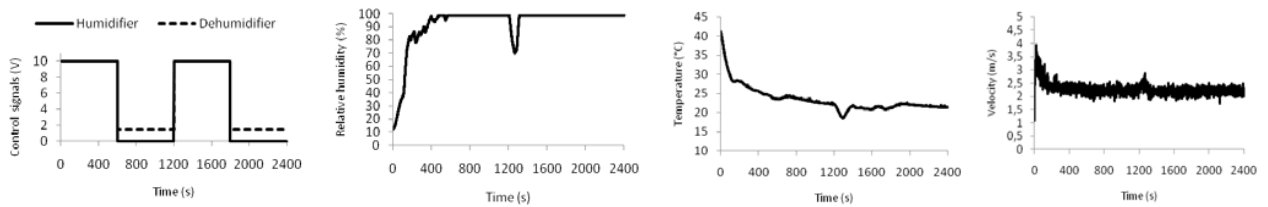

Fig. 10 Dynamics of drying process parameters when dehumidifier and humidifier control signals are changed.

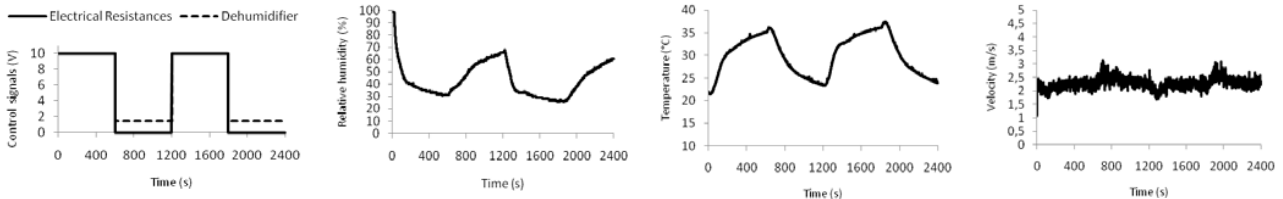

Fig. 11 Dynamics of drying process parameters when dehumidifier and electrical resistances control signals are changed.

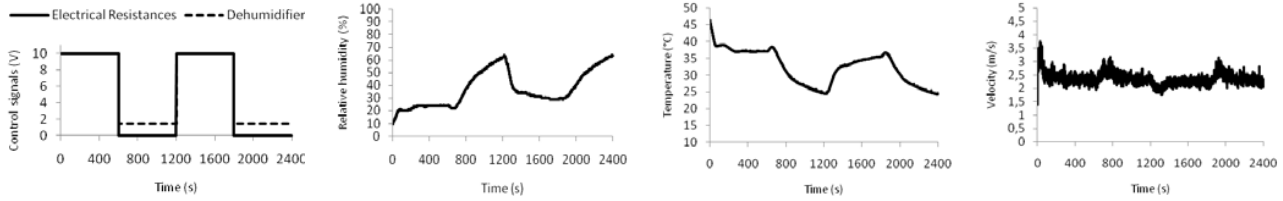

Fig. 12 Dynamics of drying process parameters when dehumidifier and electrical resistances control signals are changed.

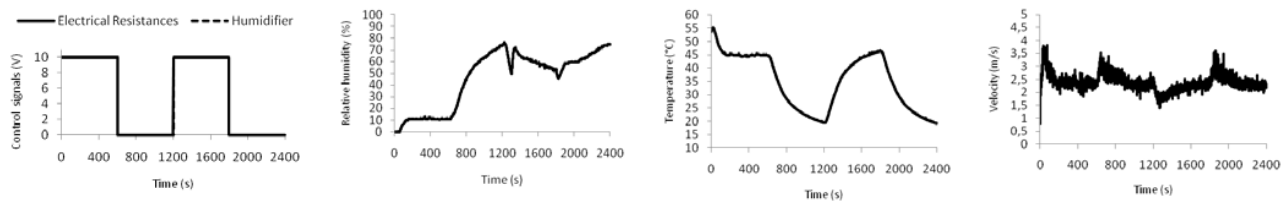

Fig. 13 Dynamics of drying process parameters when humidifier and electrical resistances control signals are changed.

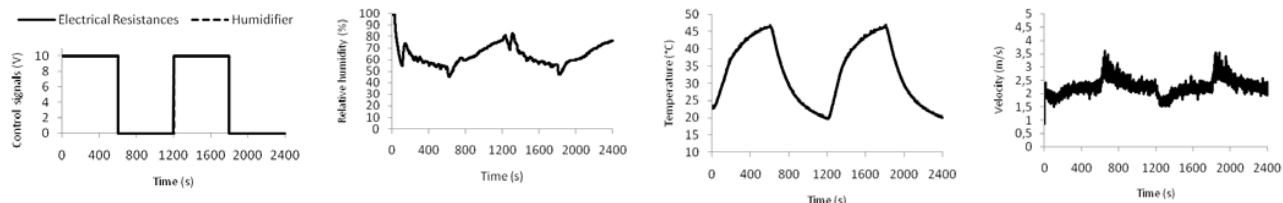

Fig. 14 Dynamics of drying process parameters when humidifier and electrical resistances control signals are changed.

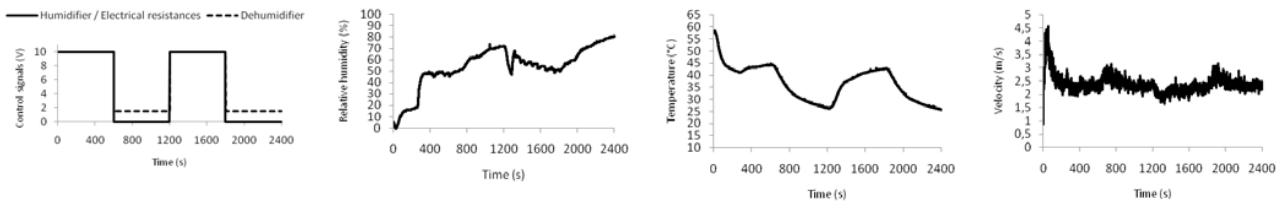

Fig. 15 Dynamics of drying process parameters when dehumidifier, humidifier and electrical resistances control signals are changed.

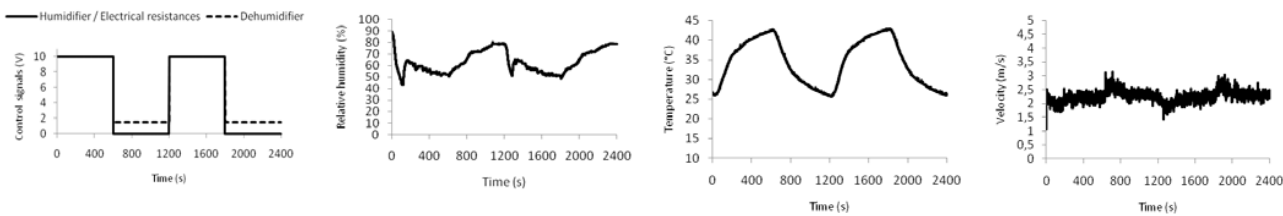

Fig. 16 Dynamics of drying process parameters when dehumidifier, humidifier and electrical resistances control signals are changed.

VI. CONTROLLERS DESIGN

A. Overall MIMO-based Controllers

Fuzzy logic has proven its worth as a practical problem-solving tool when the physical constraints are underlined. The fuzzy logic is appropriated for modeling and controlling complex, nonlinear systems because it systematically handles ambiguity. Because of this, a fuzzy control system for codfish drying experiments has been proposed. The main aim is to find the optimal air parameters for codfish drying. The effect of the drying agent parameters, namely relative humidity, temperature and air velocity, on the codfish needs more research. In fact, there are not studies about this matter at all. Therefore, it has been necessary to build up dryer controllers, which air parameters must be controlled efficiently to study the dryer behavior of the codfish at different conditions.

As can be seen in figures 17 and 18, the overall drying controller was first designed using a Hybrid Bang-bang+PI (BIP) control scheme, but was later upgraded to three fuzzy controllers: the Fuzzy Dehumidifier Controller (FDC-PD), the Fuzzy Humidifier Resistances Controller (FHRC-PD) and the Fuzzy Electrical Resistances Controller (FERC-PD). These controllers were designed through heuristic information to build a *human-in-the-loop* controller in order to emulate a decision-through-expertise-collection. As opposed to *conventional* control approaches, fuzzy control can be built on top of the programmer expert's experience. Hence, the control system performance was not designed to be a function of any mathematical models accuracy, avoiding a lot of hard questions about lower-order design models required by several control techniques, such as MPC [6], [37] – [38].

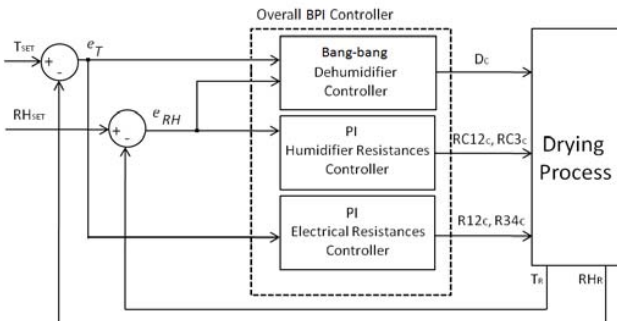

Fig. 17 Overall BPI controller for dryer process.

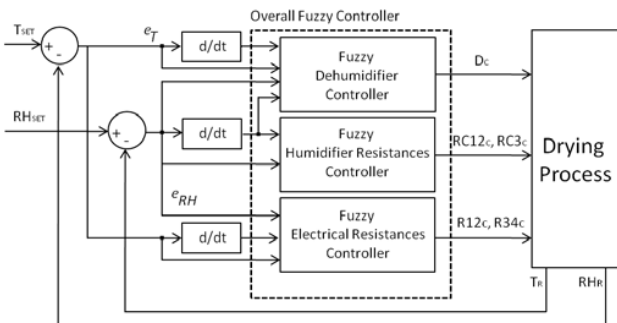

Fig. 18 Overall fuzzy controller for dryer process.

About the FLC parameterization, the “mamdani” inference mechanism, the “minimum” implication, the “maximum” aggregation and the “COG” defuzzification methods were applied to all controllers.

FLC algorithm's on-line processing may demand a high computational cost. This problem can be solved using a matrix representation of the parameterized fuzzy models. Using the Fuzzy Logic Toolbox's functions of the MATLAB® software, it's possible to get n-dimensional Look-up-tables (LUT) to allow real-time processing [39] – [40].

The relative humidity and temperature measures were filtered with 4th order Bessel lowpass filters.

B. Overall Hybrid Bang-bang+PI Controller

The dehumidifier controller was not projected as a PID controller with Pulse Width Modulation (PWM) output because of the dehumidifier constrains. In fact, switching on the dehumidifier more than twenty times a day could damage it. Therefore, it was applied the following control law:

$$D_C(t) = \begin{cases} 1 & T_{SET} < T_R \cup RH_{SET} < RH_R \\ 0 & T_{SET} \geq T_R \cup RH_{SET} \geq RH_R \end{cases} \quad (1)$$

The PI Humidifier Resistances controller has the control law:

$$RC_{12,3C}(t) = K_{P_RC} e_{RH}(t) + K_{I_RC} \int_0^t e_{RH}(t) dt \quad (2)$$

The control law of the PI Electrical Resistances controller is:

$$R_{12,34C}(t) = K_{P_R} e_T(t) + K_{I_R} \int_0^t e_T(t) dt \quad (3)$$

Both PI controller parameters were found through the Ziegler-Nichols method, which conducted to: $K_{P_RC} = 5$; $K_{I_RC} = 0.1$; $K_{P_R} = 2$; $K_{I_R} = 0.02$. An anti-windup technique was also built-in to avoid the large increase of the integral action.

C. Fuzzy Dehumidifier Controller (FDC-PD)

This FDC-PD controller gets a nonlinear action of the current and future's error, through a four dimensional MISO FLC that defines the proportional and derivative control mapping of the relative humidity and temperature. Fifteen fuzzy sets and eighty one rules were parameterized to define the nonlinear behavior between the four inputs and the controller output: three for each input and three for the output. Equations 4 and 5 describe the FDC-PD control law, whereas figures 19 to 24 represents the three-dimensional control surfaces achieved from the four-dimensional control law.

$$D_C(t) = K_{FDC} K_{FDC_out} \quad (4)$$

$$K_{FDC} = f(K_{T_in} e_T(t), K_{dT_in} \dot{e}_T(t), K_{RH_in} e_{RH}(t), K_{dRH_in} \dot{e}_{RH}(t)) \quad (5)$$

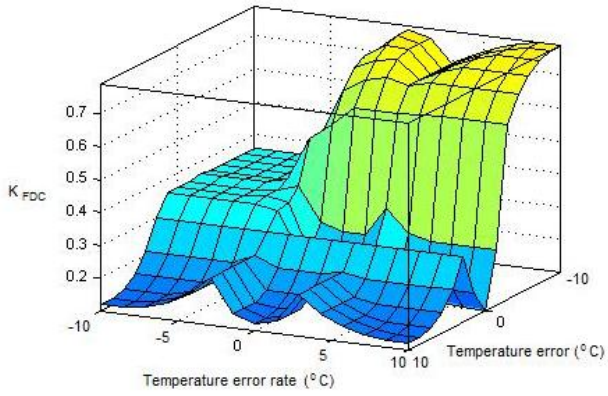

Fig. 19 FDC's control surface - the temperature error and the temperature error rate.

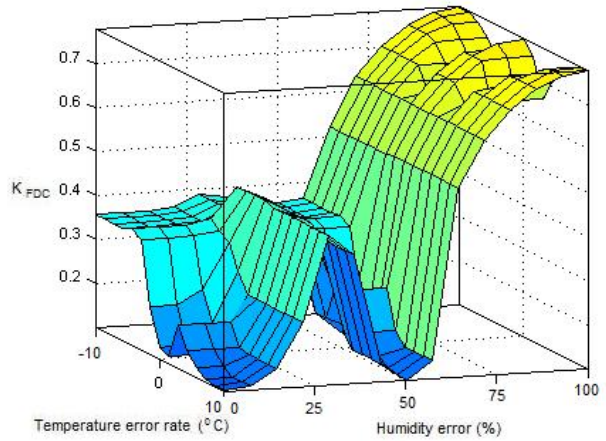

Fig. 22 FDC's control surface - the humidity error and the temperature error rate.

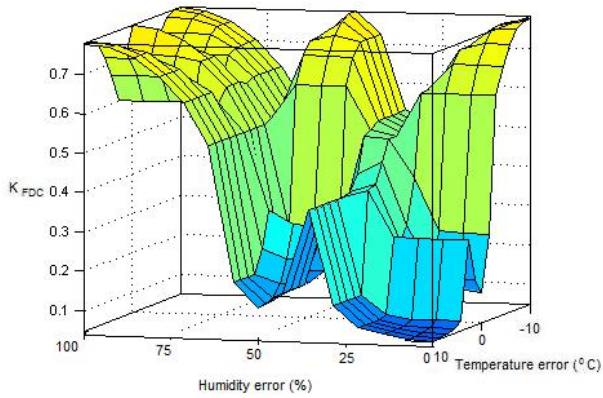

Fig. 20 FDC's control surface - the temperature error and the humidity error.

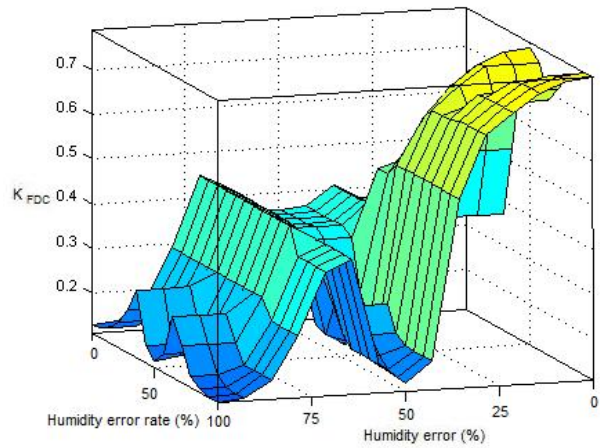

Fig. 23 FDC's control surface - the humidity error and the humidity error rate.

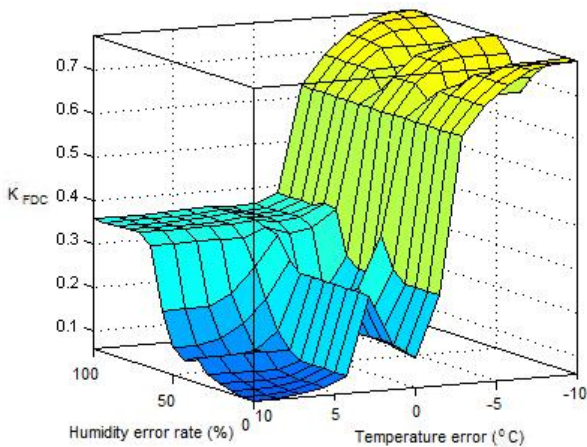

Fig. 21 FDC's control surface - the temperature error and the humidity error rate.

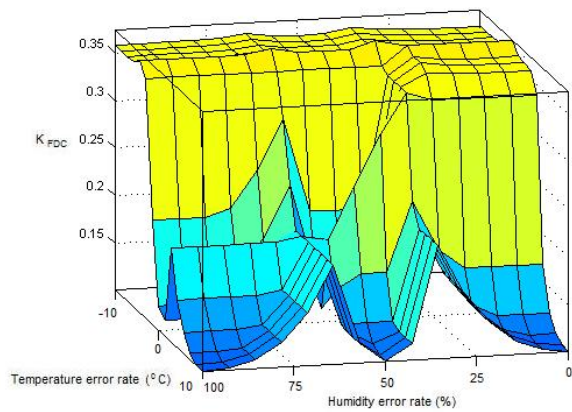

Fig. 24 FDC's control surface - the temperature error rate and the humidity error rate.

Through manual tuning, this controller was optimized with the following parameters: $K_{T_in} = 0.95$; $K_{dT_in} = 0.003$; $K_{RH_in} = 0.8$; $K_{dRH_in} = 0.005$; $K_{FDC_out} = 10$.

D. Fuzzy Humidifier Resistances Controller (FHRC-PD)

This FHRC-PD controller gets a nonlinear action of the current and future's error, through a two dimensional MISO FLC that defines the proportional and derivative control mapping of the relative humidity. Ten fuzzy sets and nine rules were parameterized to define the nonlinear behavior between the two inputs and the controller output: three for each input and four for the output. Equations 6 and 7 present the FHRD-PD control law, whereas in figure 25 the corresponding control surface is represented.

$$RC_{12,3C}(t) = K_{FHRC} K_{FHRC_out} \tag{6}$$

$$K_{FHRC} = f(K_{RH_in}e_{RH}(t), K_{dRH_in}\dot{e}_{RH}(t)) \tag{7}$$

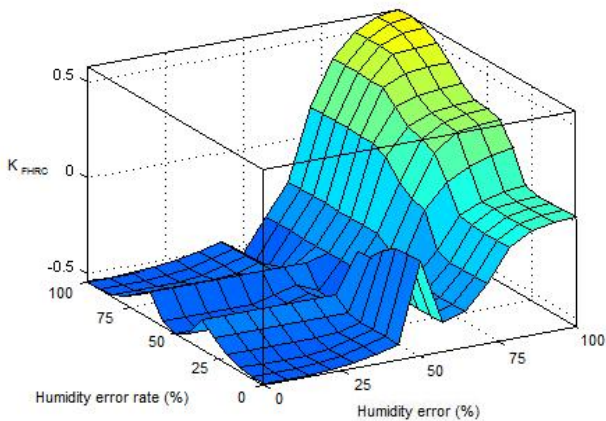

Fig. 25 FHRC's control surface

Through manual tuning, this controller was optimized with the following parameters: $K_{RH_in} = 0.8$; $K_{dRH_in} = 0.005$; $K_{FDC_out} = 10$.

E. Fuzzy Electrical Resistances Controller (FERC_PD)

This FERC-PD controller gets a nonlinear action of the current and future's error, through a three dimensional MISO FLC that defines the proportional and derivative control mapping of the relative humidity and temperature. Twelve fuzzy sets and twenty seven rules were parameterized to define the nonlinear behavior between the three inputs and the controller output: three for each input and three for the output. Equations 8 and 9 define the FHRD-PD control law, whereas figures 26 to 28 represent the corresponding control surface form the three-dimensional control law.

$$R_{12,34C}(t) = K_{FERC} K_{FERC_out} \tag{8}$$

$$K_{FERC} = f(K_{T_in}e_T(t), K_{RH_in}e_{RH}(t), K_{dT_in}\dot{e}_T(t)) \tag{9}$$

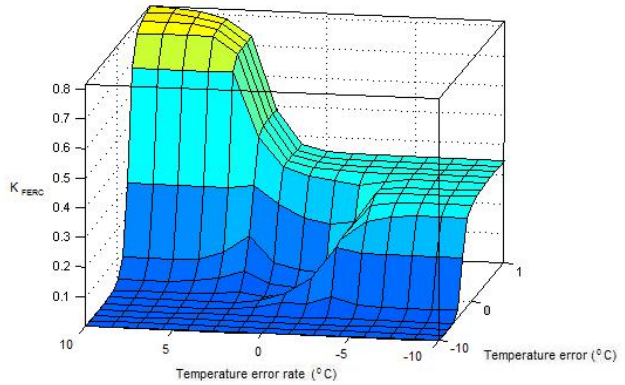

Fig. 26 FERC's control surface - the temperature error and the temperature error rate.

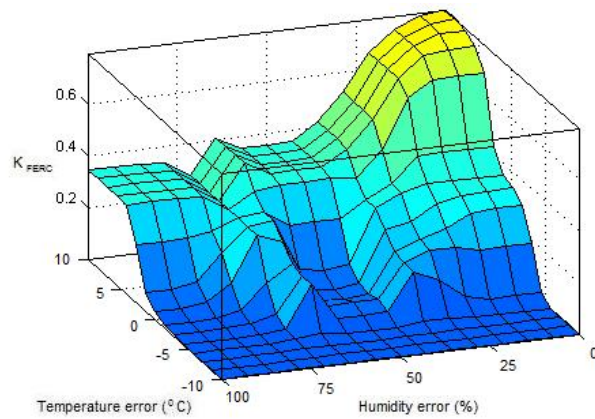

Fig. 27 FERC's control surface - the temperature error and the humidity error.

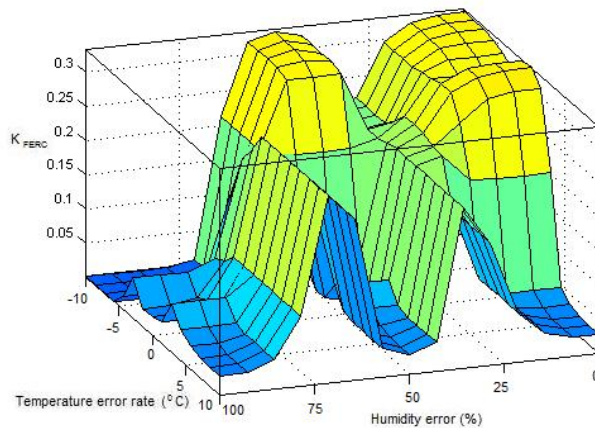

Fig. 28 FERC's control surface - the temperature error rate and the humidity error.

Through manual tuning, this controller was optimized with the following parameters: $K_{T_in} = 2$; $K_{dT_in} = 0.003$; $K_{RH_in} = 0.01$; $K_{FDC_out} = 20$.

VII. EXPERIMENTAL RESULTS

A. Relative Humidity Tracking Tasks

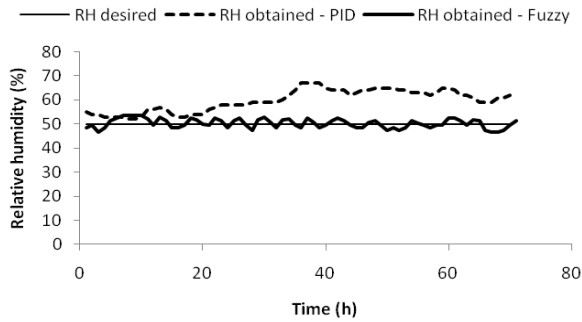

Fig. 29 PID and FLC controllers' answer to a step (experiment 1).
Experimental conditions: Temperature: 20°C; air velocity: 2 m/s.

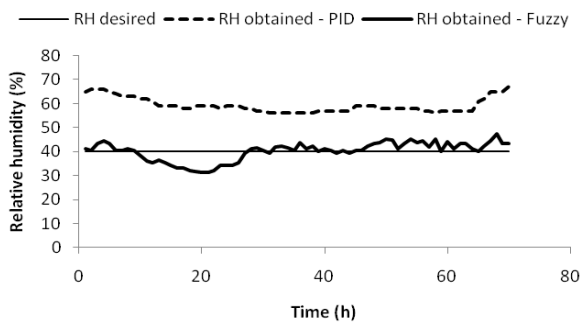

Fig. 30 PID and FLC controllers' answer to an step (experiment 2).
Experimental conditions: Temperature: 20°C; air velocity: 2 m/s.

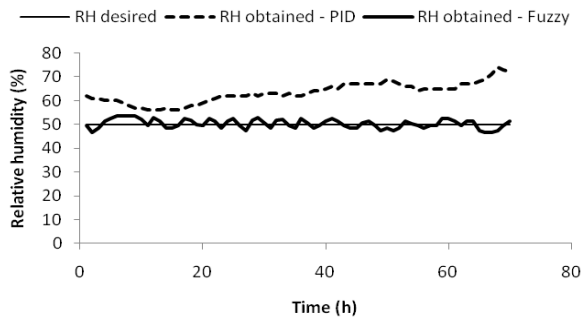

Fig. 31 PID and FLC controllers' answer to an step (experiment 3).
Experimental conditions: Temperature: 20°C; air velocity: 1.5 m/s.

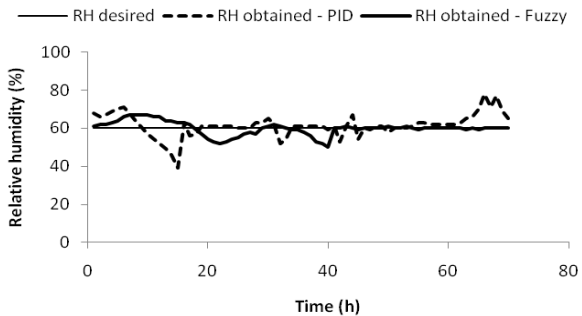

Fig. 32 PID and FLC controllers' answer to an step (experiment 4).
Experimental conditions: Temperature: 20°C; air velocity: 2 m/s.

B. Controller Performance Analysis and Discussion

Controllers' performance were analyzed through several criteria evaluation, namely mean humidity values (MHV), mean squared error (MSE), absolute mean error (AME), absolute lower error (ALE), absolute higher error (AHE), relative mean error (MRE), relative lower error (RLE) and relative higher error (RHE). Table 1 was built taken the controllers response into account.

TABLE I
PID AND FLC CONTROLLERS' HUMIDITY RESPONSE TO SEVERAL STEPS

Criteria Evaluation	Tracking Task (FLC PID)			
	Test 1	Test 2	Test 3	Test 4
MHV (%)	50.3 59.8	40.5 59.7	50.3 63.3	59.9 61.5
MSE (%)	1.9 10.8	4.2 19.96	1.9 13.98	7.45 6.31
AME (%)	1.67 9.79	3.32 19.7	1.67 13.3	2.41 4.34
ALE (%)	0.02 2	0.23 16	0.02 6	0 0
AHE (%)	3.61 17	8.85 27	3.61 24	10 21
RME (%)	3.32 15.9	8.5 32.75	3.3 20.67	4.12 7.24
RLE (%)	0.05 3.85	0.57 28.6	0.05 10.7	0 0
RHE (%)	7.46 25.4	28.4 40.3	7.46 32.4	20 53.85

All the criteria show how the FLC improved the control of the drying process. Figure 33 to 36 was built with performance results from table 1: the results show that, even without a mathematical model that can explicit the drying process nonlinearities, nevertheless through open-loop experiments, it is possible to overcome all the difficulties about drying control, namely in what concerns the time dependency, drying parameters' dynamics and their interdependence, and the control signal influence on such parameters' dynamics.

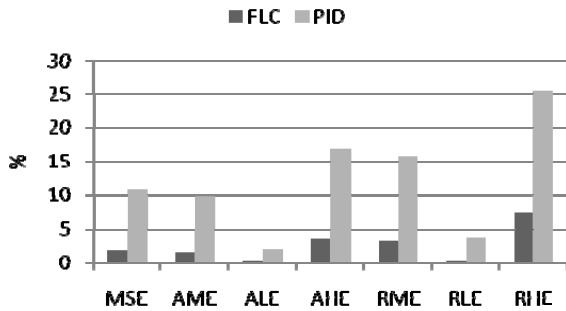

Fig. 33 PID and FLC experimental results (experiment 1).

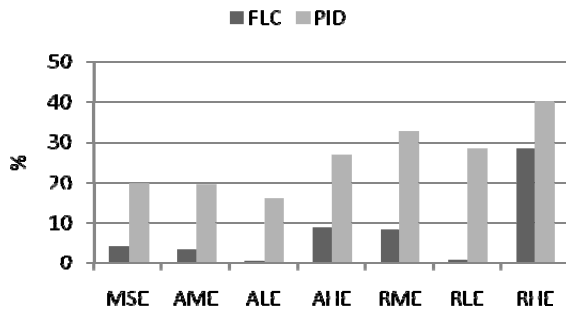

Fig. 34 PID and FLC experimental results (experiment 2).

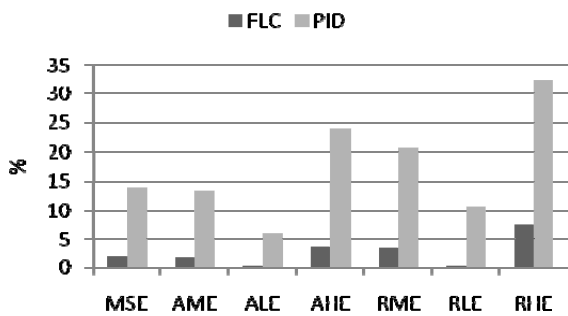

Fig. 35 PID and FLC experimental results (experiment 3).

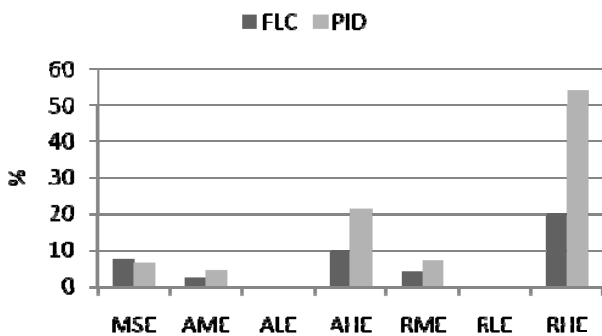

Fig. 36 PID and FLC experimental results (experiment 4).

VIII. CONCLUSION

This paper proposes the adoption of high performance non-linear fuzzy controllers for a soft real-time operation of a drying machine. The control system of machine was put into operation with MATLAB® / SIMULINK software and the hardware used was PCI-6025E data acquisition device from National Instruments®. Hybrid Bang-bang+PI (BPI) and FLC PD real-time-based controllers were implemented, tested and compared for the control of relative humidity and temperature drying parameters. The overall FLC is composed by three fuzzy controllers: Fuzzy Dehumidifier Controller (FDC-PD), Fuzzy Humidifier Resistances Controller (FHRC-PD) and Fuzzy Electrical Resistances Controller (FERC-PD).

All the criteria evaluation used for controller's performance analysis for several steps tracking tasks has showed much better performance of the fuzzy logic controller. The absolute errors were lower than 8,85 % for Fuzzy Logic Controller, about three times lower than the experimental results obtained through BPI control. Despite a reasonable number of set of rules and fuzzy sets, it was possible to carry out high performance drying controllers. Moreover, this controllers' design not took into account the mathematical model of the drying process. Nonlinear closed loop control for drying process is a promising research field that can provide the evolution of the overall control techniques.

Appendix

FDC-PD's Fuzzy Sets

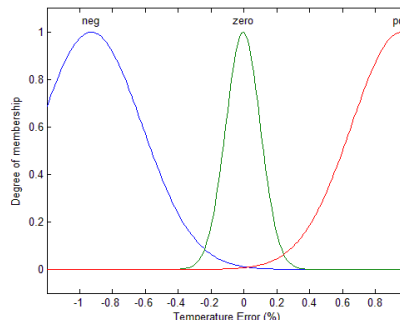

Fig. 37 FDC's temperature error fuzzy sets.

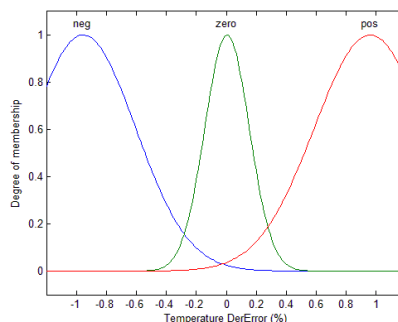

Fig. 38 FDC's temperature error rate fuzzy sets.

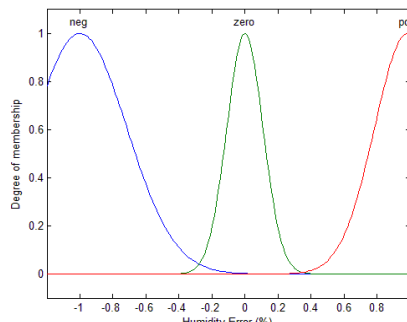

Fig. 39 FDC's humidity error fuzzy sets.

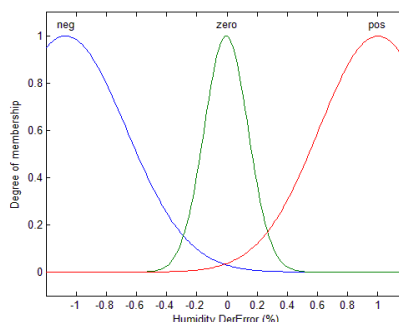

Fig. 40 FDC's humidity error rate fuzzy sets.

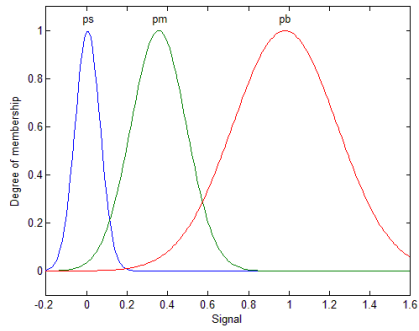

Fig. 41 FDC's output fuzzy sets.

FERC-PD Fuzzy Sets

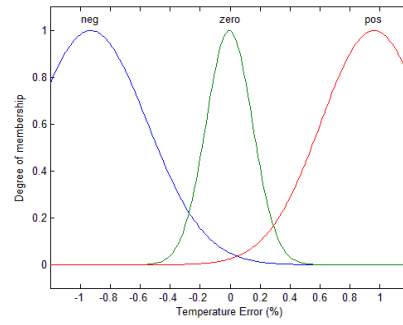

Fig. 45 FERC's temperature error fuzzy sets.

FHRC-PD Fuzzy Sets

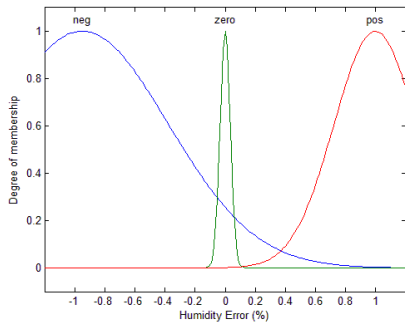

Fig. 42 FHRC's humidity error fuzzy sets.

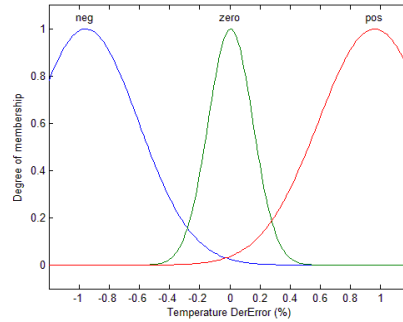

Fig. 46 FERC's temperature error rate fuzzy sets.

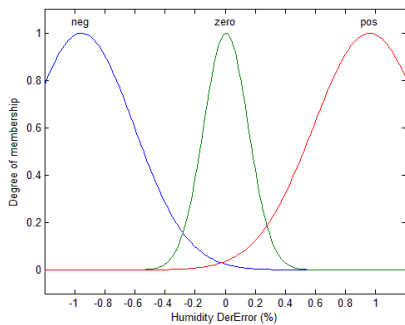

Fig. 43 FHRC's humidity error rate fuzzy sets.

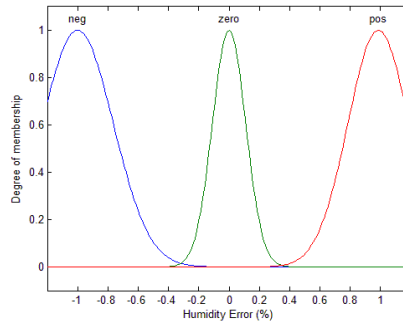

Fig. 47 FERC's humidity error fuzzy sets.

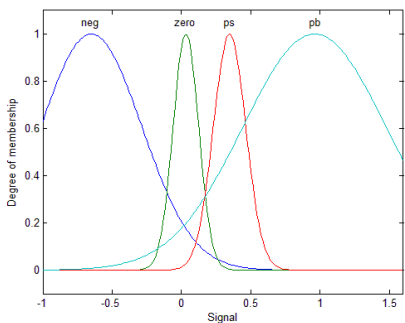

Fig. 44 FHRC's output fuzzy sets.

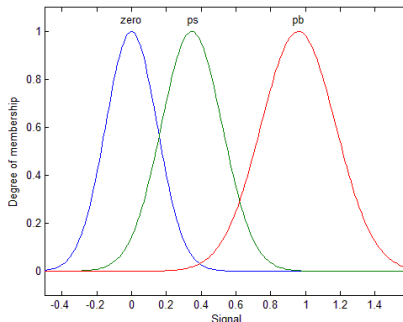

Fig. 48 FERC's output fuzzy sets.

FDC-PD's Rule-base

TABLE II
FDC-PD RULE TABLE

Output	Temp. error	Temp. error rate	Hum. error	Hum. error rate
pm	neg	neg	neg	neg
pm	neg	zero	neg	neg
pb	neg	pos	neg	neg
pm	neg	neg	neg	zero
pb	neg	zero	neg	zero
pb	neg	pos	neg	zero
pb	neg	neg	neg	pos
pb	neg	zero	neg	pos
pb	neg	pos	neg	pos
pm	zero	neg	neg	neg
pm	zero	zero	neg	neg
pm	zero	pos	neg	neg
pb	zero	neg	neg	zero
pb	zero	zero	neg	zero
pb	zero	pos	neg	zero
pb	zero	neg	neg	pos
pb	zero	zero	neg	pos
pb	zero	pos	neg	pos
pm	Pos	neg	neg	neg
pm	pos	zero	neg	neg
pm	pos	pos	neg	neg
pb	pos	neg	neg	zero
pb	pos	zero	neg	zero
pb	pos	pos	neg	zero
pb	pos	neg	neg	pos
pb	pos	zero	neg	pos
pb	pos	pos	neg	pos
pm	neg	neg	zero	neg
pb	neg	zero	zero	neg
pb	neg	pos	zero	neg
pm	neg	neg	zero	zero
pb	neg	zero	zero	zero
pb	neg	pos	zero	zero
pm	neg	neg	zero	pos
pb	neg	zero	zero	pos
pb	neg	pos	zero	pos
pm	zero	neg	zero	neg
pm	zero	zero	zero	neg
ps	zero	pos	zero	neg
pm	zero	neg	zero	zero
ps	zero	zero	zero	zero
ps	zero	pos	zero	zero
pm	zero	neg	zero	pos
ps	zero	zero	zero	pos
ps	zero	pos	zero	pos

pm	Pos	neg	zero	neg
pm	Pos	zero	zero	neg
pm	Pos	pos	zero	neg
ps	Pos	neg	zero	zero
ps	Pos	zero	zero	zero
ps	Pos	pos	zero	zero
ps	Pos	neg	zero	pos
ps	Pos	zero	zero	pos
ps	Pos	pos	zero	pos
pm	Neg	neg	pos	neg
pb	Neg	zero	pos	neg
pb	Neg	pos	pos	neg
pm	Neg	neg	pos	zero
pb	Neg	zero	pos	zero
pb	Neg	pos	pos	zero
pm	Neg	neg	pos	pos
pm	Neg	zero	pos	pos
pm	neg	pos	pos	pos
pm	zero	neg	pos	neg
ps	zero	zero	pos	neg
ps	zero	pos	pos	neg
pm	zero	neg	pos	zero
ps	zero	zero	pos	zero
ps	zero	pos	pos	zero
pm	zero	neg	pos	pos
ps	zero	zero	pos	pos
ps	pos	neg	pos	neg
ps	pos	zero	pos	neg
ps	pos	pos	pos	neg
ps	pos	neg	pos	zero
ps	pos	zero	pos	zero
ps	pos	pos	pos	zero
ps	pos	neg	pos	pos
ps	pos	zero	pos	pos
ps	pos	pos	pos	pos

FHRC-PD Rule-base

TABLE III
FHRC-PD RULE TABLE

Output	Humidity error	Humidity error rate
neg	neg	neg
neg	neg	zero
neg	neg	pos
ps	zero	neg
neg	zero	zero
neg	zero	pos
zero	pos	neg
ps	pos	zero
pb	pos	pos

FERC-PD Rule-base

TABLE IV
FERC-PD RULE TABLE

Output	Temp. error	Temp. error rate	Hum. error
zero	neg	neg	neg
zero	neg	neg	zero
zero	neg	neg	pos
zero	neg	zero	neg
zero	neg	zero	zero
zero	neg	zero	pos
zero	neg	pos	neg
zero	neg	pos	zero
zero	neg	pos	pos
ps	zero	neg	neg
ps	zero	neg	zero
zero	zero	neg	pos
ps	zero	zero	neg
zero	zero	zero	zero
zero	zero	zero	pos
zero	zero	pos	neg
zero	zero	pos	zero
zero	zero	pos	pos
ps	pos	neg	neg
ps	pos	neg	zero
zero	pos	neg	pos
pb	pos	zero	neg
ps	pos	zero	zero
ps	pos	zero	pos
pb	pos	pos	neg
pb	pos	pos	zero
pb	pos	pos	pos

REFERENCES

- [1] P. Dufour, "Control Engineering in Drying Technology: Review and Trends", *Drying Technology*, vol. 24, no. 7, pp. 889-904, 2006.
- [2] C.I. Siettos, C.T. Kiranoudis and G.V. Bafas, "Advanced Control Strategies for Fluidized Bed Dryers", *Drying Technology*, vol. 17, no. 10, pp. 2271 - 2291, 1999.
- [3] D. Zhu, J. Wang and L. Qian, "Fuzzy Immune PID Control for Drying Process Based on LS algorithm and Genetic Algorithm", in *Proc. 9th Ninth International Conference on Electronic Measurement & Instruments*, Beijing, 2009, pp. 1-234 - 1-239.
- [4] J., Carneiro and F. Almeida, "Modeling Pneumatic Servovalves Using Neural Networks", in *Proc. IEEE Conference on Computer Aided Control Systems Design*, Munich, 2006, pp. 790-795.
- [5] P. Gou, J. Comaposada, E. Serra, M. Corominas, M. Poch and J. Arnau, "Fuzzy Control System in Drying Process of Fermented Sausages", *Drying Technology*, vol. 23, no. 9, pp. 2055 - 2069, 2005.
- [6] K. Passino and S. Yurkovich, *Fuzzy Control*, California, Addison Wesley Longman, 1998.
- [7] H. E. Musch, G. W. Barton, T. A. G. Langrish and A. S. Brooke, "Nonlinear model predictive control of timber", *Computers chem. Engineering*, vol. 22, no. 3, pp. 415-425, 1998.
- [8] H. Liu, J. Zhang, X. Tang and Y. Lu, "Fuzzy Control of Mixed-Flow Grain Dryer", *Drying Technology*, vol. 21, no. 5, pp. 807 - 819, 2003.
- [9] Q. Liu and F. W. Bakker-Arkema, "Automatic Control of Crossflow Grain Dryers, Part 2: Design of a Model-Predictive Controller", *Journal. Agric. Engineering Res.*, vol. 80, no. 2, pp. 173-181, 2001.
- [10] T. Thyagarajan, J. Shanmugam, M. Ponnaivaikko and R. C. Panda, "Hybrid Intelligent Control Scheme For Air Heating System Using Fuzzy Logic and Genetic Algorithm", *Drying Technology*, vol. 18, no. 1, pp. 165 - 184, 2000.
- [11] H. Abukhalifeh, R. Dhib and M. E. Fayed. "Model Predictive Control of an Infrared-Convective Dryer", *Drying Technology*, vol. 23, no. 3, pp. 497 - 511, 2005.
- [12] T. Kokko, P. Lautala and T. Huhtelin, "Advanced Control Strategy for Impingement Drying", *Drying Technology*, vol. 21, no. 10, pp. 1969 - 1990, 2003.
- [13] P. Dufour, D. Blanc, Y. Touré and P. Laurent, "Infrared Drying Process of an Experimental Water Painting: Model Predictive Control", *Drying Technology*, vol. 22, no. 1, pp. 269 - 284, 2004.
- [14] A. Schuster and M. Kozek, "Constrained Model Predictive Control Implementation in an Industrial Drying Process", in *Proc. IEEE 7th International Conference on Computational Cybernetics*, Palma de Mallorca, 2009, pp.191-196.
- [15] U. Yüzgeç, Y. Becerikli and M. Türker, "Dynamic Neural-Network-Based Model-Predictive Control of an Industrial Baker's Yeast Drying Process", *IEEE Transactions on Neural Networks*, Vol. 19, No. 7, pp. 1231 - 1242, 2008
- [16] H. Abukhalifeh, R. Dhib and M.Fayed, "Model Predictive Control of an Infrared-Dryer", in *Proc. International Conference on Physics and Control*, St. Petersburg, 2003, pp. 340 - 344.
- [17] O. Slätteke, "Object-Oriented Modeling and Predictive Control of the Moisture Content in Paper Production", in *Proc. American Control Conference*, Minneapolis, Minnesota, USA, 2006, pp. 5544 - 5549.
- [18] U. Taira, "Energy Saving Type Temperature-Humidity Simultaneous Control Method", in *Proc. SICE Annual Conference*, Sapporo, Japan, 2004, pp. 2640-2643.
- [19] N. A. Corrêa, R. G. Corrêa, and J. T. Freire, "Self-tuning Control of Egg Drying in Spouted Bed Using the GPC Algorithm", *Drying Technology*, vol. 20, no. 4, pp. 813 - 828, 2002.
- [20] I. Alvarez-López, O. Llanes-Santiago and J. L. Verdegay, "Drying process of tobacco leaves by using a fuzzy controller", *Fuzzy Sets and Systems*, no. 150, pp. 493-506, 2005.
- [21] S. Athajariyakul and T. Leephakpreeda, "Fluidized bed paddy drying in optimal conditions via adaptive fuzzy logic control", *Journal of Food Engineering*, no. 75, pp. 104-114, 2006.
- [22] X. G. Wang, W. Liu, L. Gu, C. J. Sun, C. E. Gu and C. W. de Silva, "Development of an Intelligent Control System for Wood Drying Processes", in *Proc. IEEHASME International Conference on Advanced Intelligent Mechatronics*, Como, Italy, 2001, pp. 371 - 376.
- [23] A. Azadeh, N. Neshat and M. Saberi, "An Intelligent Approach for Improved Predictive Control of Spray Drying Process", in *Proc. 14th International Conference on Intelligent Engineering Systems*, Las Palmas of Gran Canaria, Spain, 2010, pp. 127 - 136.
- [24] Y. Zhang, X. Shi and Q. Ling, "A Method for Milk Powder Spray-drying Based on Composite Fuzzy Control Technology", in *Proc. IEEE International Conference on Mechatronics and Automation*, Changchun, China, 2009, pp. 2133 - 2137.
- [25] L. Sun, Z. Li and W. Cao, "Design and Realization of Fuzzy Self-tuning PID Controller Based on TMS320LF2407A DSPs for Microwave-Vacuum Wood Drying", in *Proc. 6th International Conference on Fuzzy Systems and Knowledge Discovery*, Tianjin, 2009, pp. 71 - 75.
- [26] T. Thyagarajan, J. Shanmugam, M. Ponnaivaikko and P. G. Rao, "Advanced Control Schemes for Temperature Regulation of Air Heat Plant", in *Proc. IEEE International Fuzzy Systems Conference*, Seoul, Korea, 1999, pp. II-767 - II-772.
- [27] Y. Guo, D. Cao and G. Zheng, "Application of Intelligent Control Techniques for Temperature- Humidity Control in Industrial Workshops", in *Proc. 2nd International Symposium on Intelligent Information Technology and Security Informatics*, Moscow, 2009, pp. 192 - 194.
- [28] M. Becker, D. Oestreich, H. Hasse and L. Litz, "Fuzzy Control for Temperature and Humidity in Refrigeration Systems", in *Proc. III IEEE Conference on Control Applications*, Glasgow 1994, pp. 1607-1612.
- [29] M. Nachidi, A. Benzaouia and F. Tadeo, "Temperature and humidity control in greenhouses using the Takagi-Sugeno fuzzy model", in *Proc.*

2006 *IEEE International Conference on Control Applications*, Munich, 2006, pp. 2150–2154.

- [30] C.N. Boeri, F.J. Neto da Silva and J.A.F. Ferreira, “Salted codfish drying kinetics: utilization of a semi-empirical simulation model”, *In 11th Pan-American Congress of Applied Mechanics*, Foz do Iguaçu, 2010.
- [31] C.N. Boeri, F.J. Neto da Silva and J.A.F. Ferreira, “Utilização de modelos semi-empíricos na simulação da secagem de bacalhau”, *In: III Conferência Nacional em Mecânica de Fluidos, Termodinâmica e Energia*, Bragança, 2009.
- [32] Mathworks© - Real-Time Windows Target. Available in (July, 2010): <http://www.mathworks.com/products/rtwt/>
- [33] S. Bellagha, E. Amami, A. Farhat and N. Kechaou, “Drying kinetics and characteristic drying curve of lightly salted sardine (*sardinella aurita*)”, *Drying Technology*, vol. 20, no. 7, pp. 1527–1538, 2002.
- [34] A. Andre’s, S. Rodriguez-Barona, J. M. Barat and P. Fito. “Salted cod manufacturing: influence of salting procedure on process yield and product characteristics”, *Journal of Food Engineering*, vol. 69, pp. 467–471, 2005.
- [35] S. Bellagha, A. Sahli, A. Farhat, N. Kechaou and A. Glenza, “Studies on salting and drying of sardine (*Sardinella aurita*): Experimental kinetics and modeling”, *Journal of Food Engineering*, vol. 78, pp. 947–952, 2007.
- [36] J.M. Barat, L. Gallart-Jornet, A. Andre’s, L. Akse, M. Carlehög and O.T. Skjerdal, “Influence of cod freshness on the salting, drying and desalting stages”, *Journal of Food Engineering*, vol. 73, pp. 9–19, 2006.
- [37] B. Kosko, *Neural Networks and Fuzzy Systems*. Prentice-Hall, 1992.
- [38] L. Wang, *Adaptative Fuzzy Systems and Control*. Prentice-Hall, 1994, pp. 210-220.
- [39] J. Ferreira, P. Sun and J. Grácio, “Design and Control of a Hydraulic Press”, *Proc. 2006 IEEE Conference on Computer Aided Control Systems Design*, Munich, 2006, pp. 814-819.
- [40] M. Santos, *Controlo de um Sistema Servopneumático para Ensaios de Fadiga*, Master Thesis in Industrial Automation Engineering, University of Aveiro, Aveiro, Portugal. 2009.



J. A. Ferreira is graduated in Electronics and Telecommunications Engineering program at the University of Aveiro, Portugal, in 1990. He obtained the M.Sc. degree in Electronics and Telecommunications Engineering in 1994 and the Ph. D degree in Mechanical Engineering in 2003, both from the University of Aveiro. He is now an Assistant Professor in the Mechanical Engineering Department at the University of Aveiro. His research interests transverse

the industrial automation field in areas such as modelling and simulation of physical systems, with more emphasis in fluid power systems, hardware-in-the-loop simulation or instrumentation and control. Recently he joins the Biomechanics group at the University of Aveiro where he has special interests in the area of intelligent bio-devices.



F. J. Neto da Silva is a Professor at Aveiro University since 1997 where he lectures in the fields of Applied Thermodynamics, Thermal Machines, Heat Transfer (Basic and Advanced) and Energy Technologies. F. Neto da Silva is a Mechanical Engineer who graduated from Coimbra University in 1985. He concluded his PhD at Cranfield University in the UK and developed his professional activity both in industry and at Higher Education institutions. The main research subjects are drying, biofuels and

micro-cogeneration.



M. P. Soares dos Santos received the B.S degree in Electronic and Computer Engineering from the Engineering College of the University of Porto, Portugal, in 2004, and the MSc degree in Industrial Automation Engineering from University of Aveiro, Portugal, in 2009.

Since 2006, he integrates the research group of Centre for Mechanical Technology and Automation, at the University of Aveiro. He is preparing the

PhD thesis in Mechanical Engineering at the University of Aveiro. His current research interests include non-linear control and physiologic supply system for in vivo evaluation of orthopedic implants.



C. N. Boeri has a B.S degree in Mathematics (2003) by Regional University Northwestern State of Rio Grande do Sul - Unijui (Brazil), specialization in Mathematics and Physics (2005) from Regional Integrated University of High Uruguay and Missions – Uri (Brazil) and the MSc in Mathematical Modeling (2007) by Unijui, Brazil.

Since April 2008, she integrates the research group of Centre for Mechanical

Technology and Automation – TEMA at the University of Aveiro - Portugal. His PhD thesis in Mechanical Engineering is about modeling and optimization of food products drying. His current research interests include modeling, non-linear control and food drying process.