

The Effect of Mixture Velocity and Droplet Diameter on Oil-water Separator using Computational Fluid Dynamics (CFD)

M. Abdulkadir* and V. Hernandez-Perez

Abstract—The characteristics of fluid flow and phase separation in an oil-water separator were numerically analysed as part of the work presented herein. Simulations were performed for different velocities and droplet diameters, and the way this parameters can influence the separator geometry was studied.

The simulations were carried out using the software package Fluent 6.2, which is designed for numerical simulation of fluid flow and mass transfer. The model consisted of a cylindrical horizontal separator. A tetrahedral mesh was employed in the computational domain. The condition of two-phase flow was simulated with the two-fluid model, taking into consideration turbulence effects using the k- ϵ model.

The results showed that there is a strong dependency of phase separation on mixture velocity and droplet diameter. An increase in mixture velocity will bring about a slow down in phase separation and as a consequence will require a weir of greater height. An increase in droplet diameter will produce a better phase separation. The simulations are in agreement with results reported in literature and show that CFD can be a useful tool in studying a horizontal oil-water separator.

Keywords—CFD, droplet diameter, mixture velocity

I. INTRODUCTION

THE API design code is the existing design method for separators. It is based on rules of thumb; it does not look at complex phenomena that happen inside the separator. Building prototypes is both time consuming and expensive. Even if the design task is accomplished, the prototypes provide limited information as to why a particular design did or did not work. As a consequence of this, results may be obtained that are not exact and often lead to overdesign of the separator.

M. Abdulkadir, the corresponding author, is a PhD student in the Process and Environmental Engineering Research Division, Chemical and Environmental Engineering Department, the University of Nottingham, University Park, Nottingham, NG7 2RD, United Kingdom.
Email address: enxma17@nottingham.ac.uk

V. Hernandez-Perez is a research fellow in the Process and Environmental Engineering Research Division, Chemical and Environmental Engineering Department, the University of Nottingham, University Park, Nottingham, NG7 2RD, United Kingdom

Also, separation which is one component of a production phase poses a distinctive challenge on a floating platform because of the unavoidable wave motion to be expected at sea.

These wave motions, i.e. pitch, heave, yaw, sway, surge and roll are present even in calm weather conditions. They tend to have a natural mixing effect on the oil, water and gas, thereby resulting in an increase in the time it takes to separate the mixture. The API design code has no answer to such a challenge. An approach that can provide solutions to the aforementioned problems is Computational fluid dynamics (CFD).

Computational fluid dynamics is a very complex and challenging subject. It operates on quite simple laws such as laws of thermodynamics, conservation, momentum, energy, and Euler equations. The partial differential equations known as Navier- Stokes equations ensuing from these laws are what govern fluid dynamics. Solving the Navier-Stokes equations involves the use of sophisticated solution algorithms. These work by processing initial fluid flow conditions which form the basis for the prediction of the next flow conditions. CFD is more suited to steady state flow which is less demanding for the computer and enables solution to be achieved within a reasonable number of iterations.

This branch of fluid dynamics called computational fluid dynamics complements experimental and theoretical fluid dynamics by providing an alternative cost-effective means of simulating real flows. As such it offers a means of testing theoretical advances for conditions unavailable experimentally [1]. Moreover, there are several unique advantages of CFD over experimental-based approaches to fluid systems design:

- Optimization by such techniques can enhance performance;
- can simulate flow conditions not reproducible in experimental model tests;
- provides more detailed and comprehensive information and better visualization for detailed insight and better understanding of the designs and processes;
- reduce concept-to-prototype time;
- produce large savings in equipment and energy costs which leads to revenue increases;
- As well as reduce environmental impact.

CFD analysis of gravitational separation can aid the design of oil, water and gas separator. Therefore, CFD is used as a tool to eliminate several physical experimentation cycles of the design process.

The design of separators has up to now mainly been based on the API design rules. The API rules are proven, but all the effects of non-ideal flow due to inlet/ outlets and internal equipment used to enhance separation are neglected. Considerable safety factors must therefore be used in design work.

With the advent of powerful computers and fluid flow modelling software, Computational Fluid Dynamics (CFD) has become an alternative tool with which to assess the performance of a separator under different regimes. Not only can the thermal effects be incorporated, but also every detail of the flow field becomes available for extracting measures of performance.

The study presented herein will attempt to determine the effect different parameters like velocity and droplet diameter will have on the separator geometry using computational fluid dynamics.

II. NUMERICAL MODEL

Computational Fluid Dynamics (CFD) solves the Navier-Stokes equations on a discretised domain of the geometry of interest with the appropriate flow boundary conditions supplied. The Navier-Stokes equations are a complex non-linear set of partial differential equations that describe the mass and momentum conservation of a fluid. In this study, the Navier-Stokes equations for two phases are used via the Control volume method in FLUENT. An Eulerian model was used for the multiphase flow model.

A CFD analysis consists of the following steps [3]:

- Problem identification and Pre-Processing
- Solver Extraction
- Post-Processing

For details of these see [7]; [2].

A. Geometry creation using Gambit 2.2

The cylindrical separator used in this project is 25 m long, with a radius of 1.25 m. A weir of non porous medium is located at 17.5 m from the inlet. Two outlets are positioned either side of the weir at the bottom of the separator at 16.5 m and 19 m from the inlet to separate water and oil respectively. The third outlet is positioned at the top of the separator at 17.5 m from the inlet. Due to symmetry only half the separator is modelled.

For complex geometries, quad/ hex meshes show no numerical advantage, and meshing effort can be saved by using a Tri/ Tetrahedral mesh [2]. Since the separator has a complex geometry, a Tri/ Tetrahedral mesh was used with an interval size of 0.12 m.

Creation of Inlet:

A cylinder of radius 0.403 m and height 2 m was created. The created cylinder was then moved to a distance of $x = -11.5$ m, $y = 0.4$ m, $z = 0$ m from the reference point (CENTERED X).

The volume of the new cylinder was split with the volume of the hemisphere. A portion of the cylinder remaining in the hemisphere was then deleted.

Creation of Outlet_gas:

A cylinder of radius 0.403 m and height 1 m was created. The created cylinder was then moved to a distance of $x = 8.75$ m, $y = 1.5$ m, $z = 0$ m from the reference point (CENTERED Y).

The volume of the new cylinder was split with the volume of the rectangular portion of the original cylinder. A portion of the new cylinder remaining inside the rectangular portion of the cylinder was then deleted.

Creation of Outlet_Water:

A cylinder of radius 0.182 m and height 1 m was created. The created cylinder was then moved to a distance of $x = 8.25$ m, $y = -1.5$ m, $z = 0$ m from the reference point (CENTERED Y).

The volume of the new cylinder was split with the volume of the original cylinder. A portion of the new cylinder remaining inside the original cylinder was deleted.

Creation of Outlet_Oil:

A cylinder of radius 0.182 m and height 1 m was created. The created cylinder was then moved to a distance of $x = 9.5$ m, $y = -1.5$ m, $z = 0$ m from the reference point (CENTERED Y).

The volume of the new cylinder was split with the volume of the original cylinder. A portion of the new cylinder remaining inside the original cylinder was deleted.

Creation of Weir:

A brick of width 0.02 m, depth 3 m and height 3 m was created. The brick was then moved to a distance of $x = 8.75$ m, $y = -1.5$ m, $z = 0$ m from the reference point (CENTERED Y).

The volume of the brick was then subtracted from the volume of the original cylinder. The shape that was produced is called a weir.

All the individual volumes were then united as one entity called a separator, see fig. 1.

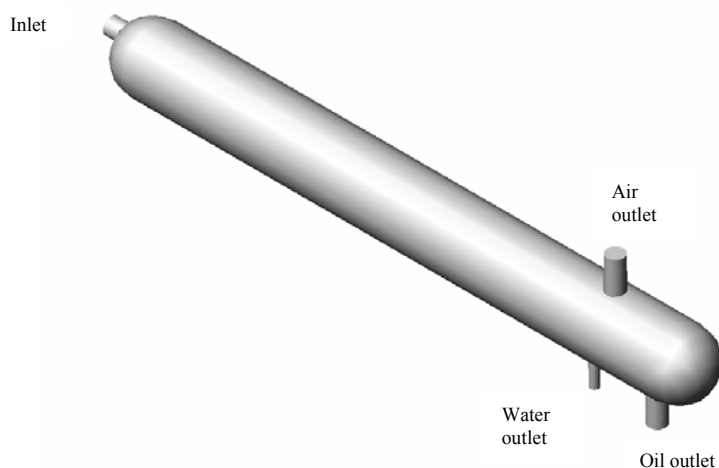

Fig. 1: 3D separator geometry

Modelling half of the Separator:

Bisecting the separator geometry by half along the X-axis will not only reduce the computation time but provide the option of controlling the density of interval counts along the ends of the edges. It also provided the opportunity of visualizing what was actually happening inside the separator.

A rectangular face was created with dimensions of: width 25 m and length 2.5 m. The separator (Volume 1) was then used to split the rectangular face (Volume 2).

Volume 2 was then subtracted from Volume 1, to form half of a separator (see fig. 2).

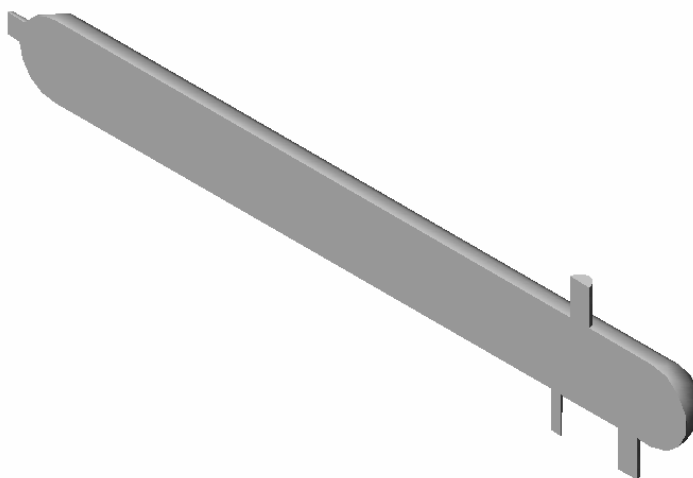

Fig. 2: 3D half of separator geometry

B. Grid generation

The separator that was developed was then meshed using Tri/ Tetrahedral mesh with an interval size of 0.12 m (see fig. 3). The number of cells generated was 181,370.

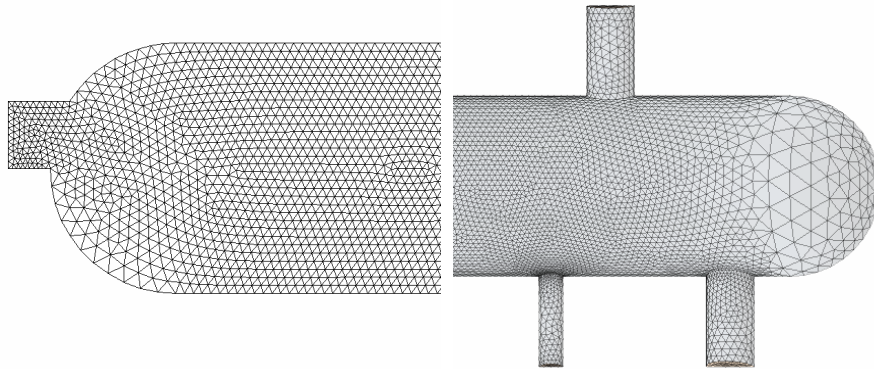

Fig. 3: Tetrahedral mesh in 3D half of separator

C. Governing equations

The modelling involves computation of velocity components in three dimensions for each phase, volume fraction and pressure for each phase. In this study, a Cartesian coordinate system was used throughout. The computation of the aforementioned parameters for each phase was performed using higher order discretization to avoid numerical diffusion. The secondary phase was characterized by a droplet diameter. Since the present study involved incompressible flows, no change was made to the pressure location. Gravity was enabled since a separator depends upon gravity to separate oil and water.

In Fluent an Eulerian model was chosen for the multiphase flow based on the assumption made that the pattern of fluid flow is a homogenous dispersed droplet type.

To effectively model the separator, the following assumptions are prescribed in the numerical computation:

- Incompressible flow;
- Steady state;
- Turbulent flow;
- No heat transfer;
- No heat radiation

Under these conditions, the governing equations for continuity equation for the phase k is written as

$$\frac{\partial}{\partial t}(\alpha_k \rho_k) + \nabla \cdot (\alpha_k \rho_k \mathbf{u}_k) = \Gamma_k \quad k=1,2 \quad (1)$$

Where α , ρ , and \mathbf{u} are the volume fraction, density and mean velocity

The momentum equations is

$$\rho \frac{D\mathbf{V}}{Dt} = \rho \mathbf{g} - \nabla p + \frac{\partial}{\partial x_i} \left[\mu \left(\frac{\partial v_i}{\partial x_j} + \frac{\partial v_j}{\partial x_i} \right) + \delta_{ij} \lambda \text{div} V \right] \quad (2)$$

where v_i is the i component of the fluid velocity \mathbf{v} , x_j is the j spatial coordinate, p is the static pressure, μ is the effective viscosity and δ_{ij} is the Kronecker delta

And the turbulent flow equations are:

$$\frac{Dk}{Dt} = \frac{\partial}{\partial x_j} \left(\frac{v_j}{\sigma_k} \frac{\partial k}{\partial x_j} \right) + v_i \frac{\partial \bar{u}_j}{\partial x_j} \left(\frac{\partial \bar{u}_i}{\partial x_j} + \frac{\partial \bar{u}_j}{\partial x_i} \right) - \varepsilon \quad (3)$$

$$\frac{D\varepsilon}{Dt} = \frac{\partial}{\partial x_j} \left(\frac{v_j}{\sigma_\varepsilon} \frac{\partial \varepsilon}{\partial x_j} \right) + C_1 v_i \frac{\varepsilon}{k} \frac{\partial \bar{u}_j}{\partial x_j} \left(\frac{\partial \bar{u}_i}{\partial x_j} + \frac{\partial \bar{u}_j}{\partial x_i} \right) - C_2 \frac{\varepsilon^2}{k} \quad (4)$$

$$v_i = \frac{\mu_t}{\rho} = \frac{C_\mu k^2}{\varepsilon} \quad (5)$$

Where k is the turbulent kinetic energy; ε is the dissipation rate of k , $C_\mu = 0.09$ $C_1 = 1.44$ $C_2 = 1.92$ $\sigma_k = 1.0$ $\sigma_\varepsilon = 1.3$

Solving these sets of equations has been done using a software package Fluent 6.2.

D. Boundary conditions

Once the mesh was generated, boundaries of computational domain were specified. Boundary type specifications define the physical and operational characteristics of the model at those topological entities that represent model boundaries.

All wall conditions were assumed to be no slip boundary. The no slip condition ($\mathbf{u} = \mathbf{v} = 0$) is the appropriate condition for the velocity component at solid walls [6]. At the inlet, velocities for both phases were prescribed. The phases were clearly defined with the Primary phase as water and the secondary phase as oil. The volume fraction and density of each phase were both prescribed at the inlet. Symmetry boundary was used at the $x - y$ plane at $z = 0$. The summary of the boundary specifications are presented below:

Inlet	Velocity inlet
Outlet oil	Pressure outlet
Outlet water.....	Pressure outlet
Outlet gas.....	Wall

Symmetry.....Symmetry
Wall.....Wall

E. Solution algorithm

The control volume approach as implemented in the commercial CFD solver, FLUENT [2] was used in this study. In this method, the governing equations are first integrated on the individual control volumes that were created in the grid generation phase, to construct algebraic equations for the discrete dependent variables such as velocities, pressure, temperature, and conserved scalars. Secondly, the discretised equations are linearised and the resulting linear equation system is solved to yield updated values of the dependent variables.

In this study, the segregated solution method of FLUENT is used, as it is suitable for incompressible flows [6].

In this approach, the governing equations are solved sequentially (i.e., segregated from one another). Because the governing equations are non-linear (and coupled), several iterations of the solution loop must be performed before a converged solution is obtained.

An IMPLICIT formulation scheme was used based on the fact that it is suitable for general purpose CFD computations on the grounds of its superior stability.

A PRESTO pressure scheme was chosen for the pressure interpolation as it is well suited for steep pressure gradients involved in swirling flows, even though it takes longer time for convergence [3].

First order upwind differencing discretization scheme was chosen for momentum, volume fraction, turbulence kinetic energy and turbulence dissipation rate in this study. The standard $k-\epsilon$ turbulence model was used for modelling turbulence based on the fact that it is the simplest turbulence model for which only initial and/or boundary conditions need to be supplied [6]. It also provides excellent performance for many industrially relevant flows.

The SIMPLE algorithm was used for pressure-velocity coupling in this project. It was selected based on the fact that it is relatively straight forward and has been successfully implemented in numerous CFD procedures.

The final converged solution was obtained by using an adequate number of iterations.

III. RESULTS AND DISCUSSION

This section will aim to compare the contours of volume fraction of oil for different mixture velocities and for those with the same mixture velocity but different droplet diameters. It will also compare the velocity vectors for simulations with

the same droplet diameter but with different mixture velocities.

Figures 4 and 5 compare the predicted oil volume fraction of simulations with the same droplet diameter of 1 mm with two different mixture velocities of 0.5 m/ s, and 1.0 m/ s respectively. Figures 6 and 7 compare the predicted oil volume fraction for simulations with the same mixture velocity of 0.5 m/ s with droplet diameters of 0.5 mm and 0.25 mm respectively. Figures 8 and 9 compare the velocity vector patterns for two mixture velocities of 0.5 m/ s and 1.0 m/ s with the same oil volume fraction of 0.5 and same droplet diameter of 1 mm. The weir height for all the cases is 1.5 m.

It can be observed that the flow of fluid from the inlet is not uniform in figures 4 to 9 inclusive. A perforated plate will be required close to the inlet to assist in the development of uniform flow across the entire liquid section.

Over the range of conditions, a range of flow patterns were observed. For efficient separation, it was observed that the density difference between the phases must be high so that they can separate out under the influence of gravity. The present study shows the possible use of CFD for separator design. Parameters such as volume fraction, droplet size, inlet and outlet location and size and weir height can be easily changed in CFD design study. Although these studies are useful for initial design, there are parameters that have not been considered at present such as gas and sand effects. Emulsification and coagulation effects, which are transient effects, were also not undertaken in this steady state study.

TABLE I DETAILS OF THE CASES INVESTIGATED

Case	Inlet Velocity (m/s)	Droplet diameter (mm)	Notes: Inlet water volume fraction = 50% Phase1 (primary phase) = water Phase 2 (secondary phase) = oil Weir height = 1.5 m
1	0.5	1	Droplet diameter = 1 mm
2	1.0	1	Droplet diameter = 1 mm
3	0.5	0.5	Droplet diameter = 0.5 mm
4	0.5	0.25	Droplet diameter = 0.25 mm

A. Comparing the contours of volume fraction of oil for a velocity of 0.5 m/s, and 1.0 m/s with a droplet diameter of 1 mm

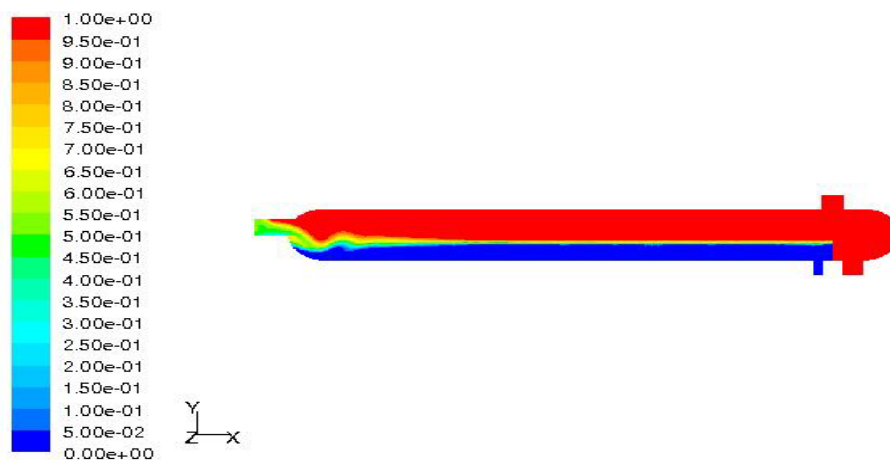

Fig. 4: contours of volume fraction of oil (1 mm diameter) for a velocity of 0.5 m/s

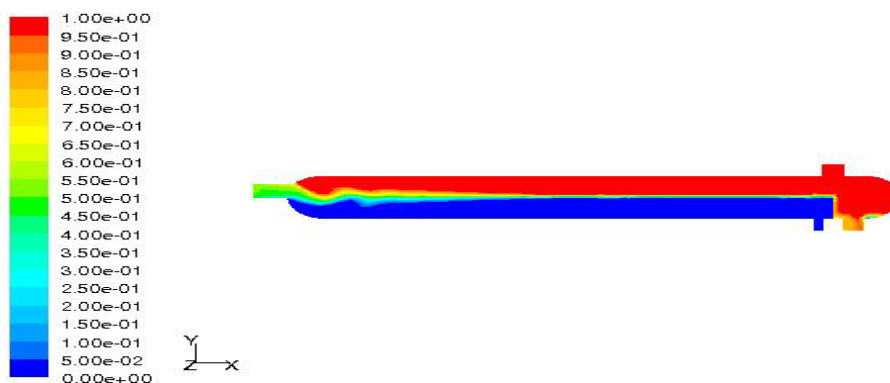

Fig. 5: contours of volume fraction of oil (1 mm diameter) for a velocity of 1.0 m/s

Comparing the contours of oil volume fraction of Cases 1 and 2 (respectively figures 4, and 5), it can be observed that the lighter oil layer floats on top of the water layer and spills over the weir into the oil chamber, where it is withdrawn, due to differences in density in all the three cases. The heavier water layer remains on the inlet side of the weir and is withdrawn through a separate interface. The weir plate allows the top layer of the oil/ water section to cascade over and accumulate in the oil only section of the separator thus facilitating separate oil and water draw offs from the vessel. The red colour according to the contour line indicates maximum oil, while blue indicates maximum water. A change in colour signifies mixed flow.

Fig. 4 show that at a mixture velocity of 0.5 m/s, the level of water in the separator is below the height of the weir, indicating that there is no overflow of water into the oil section. The weir forms a dam, which creates a section where

the water can separate out of the oil. The water falls to the bottom of the separator with the oil on top, which flows over the weir and into the oil section. However, when the mixture velocity is increased to 1.0 m/s as shown in fig. 5, the level of water in the separator has increased above the height of the weir, resulting in water spill over the weir into the oil section of the separator.

In summary, the aforementioned results showed that an increase in mixture velocity results in an increase in water level to a point where it begins to overflow into the oil section of the separator. These results obtained are in agreement with those obtained by [5]. The design of the separator should take cognisance of the mixture velocity such that when the mixture velocity is high, the geometry of the separator can be changed by increasing the weir height.

B. Comparing the contours of volume fraction of oil for a velocity of 0.5 m/s, with differing droplet diameters of 0.5 mm and 0.25 mm

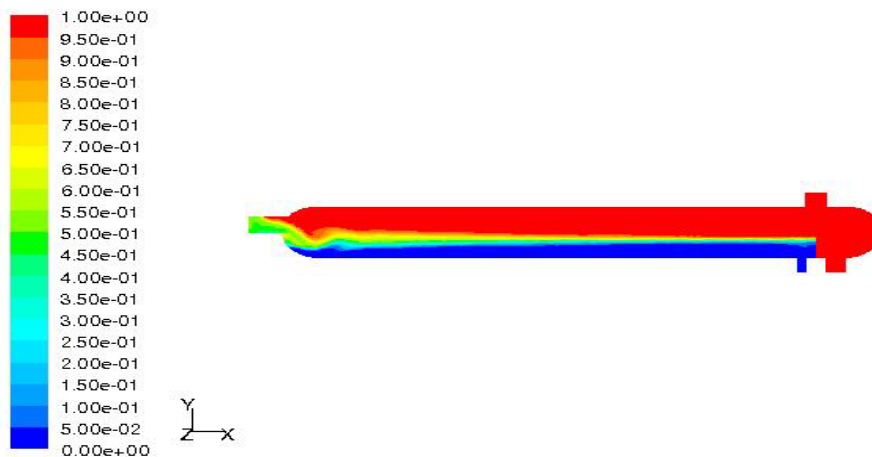

Fig. 6: contours of volume fraction of oil (0.5 mm diameter) for a velocity of 0.5 m/s

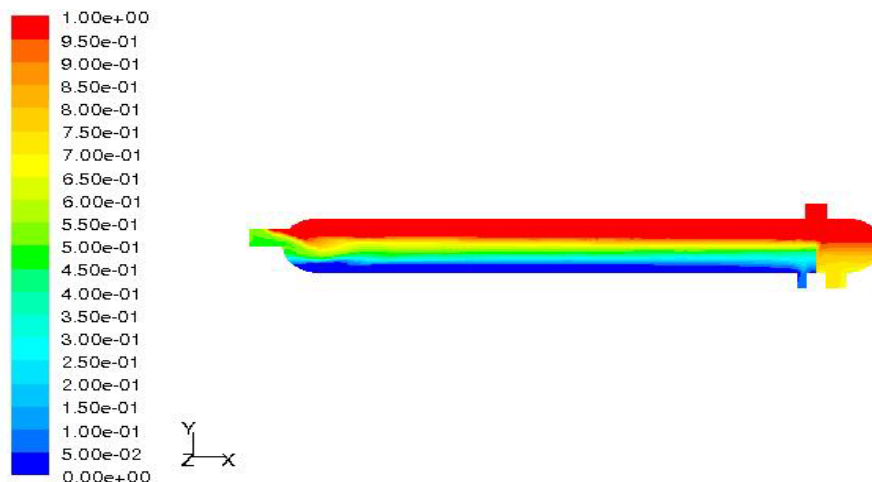

Fig. 7: contours of volume fraction of oil (0.25 mm diameter) for a velocity of 0.5 m/s

Comparing the contours of oil volume fraction of Cases 1, 3 and 4 (respectively figures 4, 6 and 7), it can be observed that there are increases in mixed flow patterns in the separator when accompanied by a decrease in droplet diameter. The mixed flow pattern showed that there is no clear change from water to oil indicating that an emulsion layer exists at the interface. Formation of emulsions occurs when oil and water is agitated inside the separator. This tends to bring about a decrease in accumulation level of the liquid required for separation.

In summary, the aforementioned results showed that with the same volume of oil, there are significant differences in separation of oil and water when different droplet sizes are selected. Indicating that the smaller droplet will result in more mixed flow than the larger bubbles where separation of two-phases is more prominent. These results obtained are in agreement with the works of [4]; [5]. The design of the separator should take cognisance of the size of the droplet diameter so as to avoid mixed flow patterns.

C. Comparing the contours of velocity vector of oil for a velocity of 0.5 m/s and 1.0 m/s with a droplet diameter of 1 mm

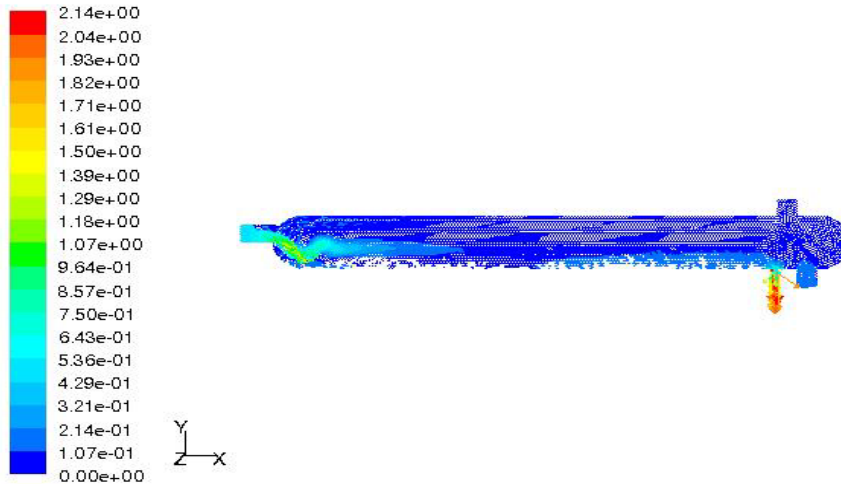

Fig. 8: contours of velocity vector of oil (1.0 mm diameter) for a velocity of 0.5 m/s

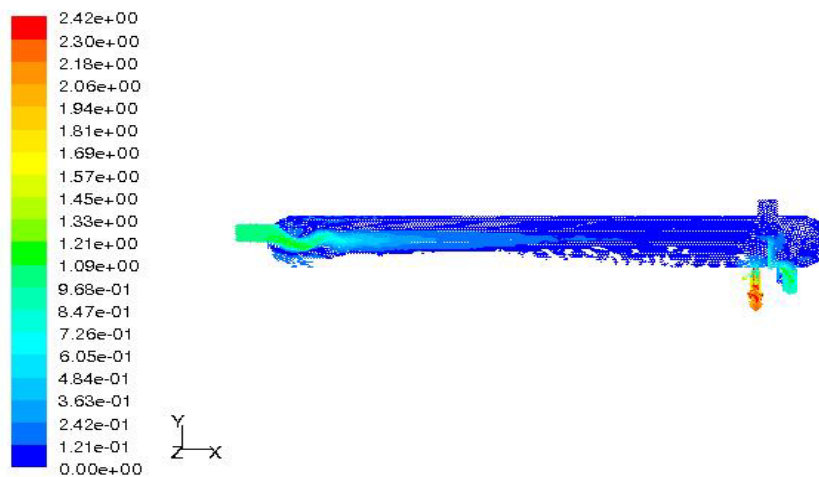

Fig. 9: contours of velocity vector of oil (1.0 mm diameter) for a velocity of 1.0 m/s

The intensity of velocity vector is depicted by different colours as shown. The maximum, medium and least intensity are represented by red, green and blue respectively. The velocity vector can be used to explain fluid movement with the red colour indicating maximum movement while blue colour indicating no movement of flow. And the green colour indicates average fluid movement. The velocity vector can also be used to explain phase separation depending on velocity. A change in colour indicates there is a phase separation going on.

It can be observed that figures 8 and 9 show the same colour red at the water outlet, indicating that there is a maximum intensity there. It shows that there is maximum movement of fluid. It also signifies that only one fluid is

present therein. It can also be observed that there is significant turbulence from the inlet into the separator; the fluid flow is not uniform. The presence of a perforated plate at the inlet is necessary to straighten flow. It can be observed that fig. 8 showed a darker colouration than fig. 9.

Fig. 8 shows a high turbulence level at the inlet, and a much darker blue colour than fig. 9 at the oil outlet. This shows that it has the least intensity therein. It also indicates that there is no fluid movement (stagnant). When the mixture velocity is 1.0 m/s, a higher turbulence compared to fig. 8 at the oil outlet and inlet are observed as shown in fig. 9.

In summary, the velocity vector shows that the movement of fluid and turbulence (at inlet and outlet) increases with mixture velocity at constant bubble diameter.

IV. CONCLUSIONS

Predicting the effect of different parameters like velocity and bubble diameters has been successfully carried out. The Eulerian model for a multiphase flow as implemented in the software Fluent 6.2 was used to solve the governing equations, while GAMBIT2.2 was used for generating the separator geometry.

The results of the analysis show that there is a strong dependency of phase separation on mixture velocity and droplet diameter. Simulations using the same volume fraction of oil with different mixture velocities and droplet diameters gave different results. The results show that a mixture velocity of 0.5 m/s produced the best result when compared with 1.0 m/s. Mixture velocity of 1.0 m/s require the weir height to be increased, so as to prevent water over flowing into the oil section of the separator. The result of 1.0 mm droplet diameter produced the best result when compared with those of 0.5 mm and 0.25 mm. The 0.5 mm and 0.25 mm showed a low phase separation, requiring a control mechanism to prevent mixed flow pattern. This is in positive agreement with the works of [4]; [5]. This concludes that the mixture velocity and droplet diameter are important parameters that influence/ affect the separator geometry. In consequence, computational fluid dynamics (CFD) techniques can prove useful in understanding important flow mechanisms in the separator and thus predict its performance. Furthermore, this study demonstrated the challenging task of modelling oil and water separator, and that more work has to be done to make the work more complete.

NOMENCLATURE

Latin letters

g	Gravitational acceleration [m/s^2]
k	Kinetic energy of turbulence [m^2/s^2]
n	number of phases [-]
p	Pressure [N/m^2]
t	Time [s]
u	Velocity [m/s]
D	Diffusion coefficient [m^2/s]

Greek letters

α	Volume fraction [-]
μ	Dynamic viscosity [$kg/m.s$]
ρ	Material density [kg/m^3]
σ	Surface tension [N/m]
τ	Stress tensor [N/m^2]
λ	Second (bulk) viscosity [$kg/m^3.s$]
Γ	Rate of mass transfer [$kg/m^3.s$]
ν	Eddy viscosity [$kg/m.s$]
ε	Rate of viscous dissipation [m^2/s]

Subscripts

i, j	Space directions
--------	------------------

k	phase index
m	mixture

Other symbols and operators

\bar{u}	Average of u
∇	Gradient operator
$\frac{\partial}{\partial t}$	Partial derivative
$\frac{D}{DT}$	Total derivative
$C_\mu, \sigma_k, \sigma_\varepsilon, C_1$ and C_2	empirical constants
δ	Kronecker delta function
x	Spatial co-ordinate
div	Divergence of a vector field

ACKNOWLEDGEMENT

M.Abdulkadir would like to express sincere appreciation to the Nigerian government through the Petroleum Technology Development Fund (PTDF) for funding of my PhD study.

REFERENCES

- [1] Fletcher, C.A.J., 1991. Computational techniques for fluid dynamics, Vol.1. 2nd ed. Berlin: Springer
- [2] FLUENT INC., 2001. Gambit version 2 manuals, Centerra Resource Park, 10 Cavendish Court, Lebanon, New Hampshire, USA. Available from: <http://www.fluent.com>
- [3] FLUENT INC., 2003. Fluent 6 introductory training notes. Available from: <http://www.fluent.com>
- [4] Hallanger, A., Soenstabo, F., and Knutsen, T., 1996. A simulation model for three-phase gravity separators. Proceedings of SPE Annual Technical Conference and Exhibition. Denver, Colorado: SPE, 6 – 9 October, pp. 5 – 7
- [5] Holdo, A.E. and Calay, R.K., 2006. Two-phase Flow Modelling for Industrial Applications, Fluid Mechanics Research Group, UK: University of Hertfordshire Hatfield Herts.
- [6] Versteeg, H.K. and Malalasekera, W., 2007. An Introduction to Computational Fluid Dynamics: the Finite Volume Method. 2nd ed. Pearson Educational Limited.
- [7] White, F.M., 1991. Viscous Fluid Flow. 2nd ed. New York: McGraw – Hill