

# Development of Low-Profile Antenna for Mini UAV with Reconnaissance Mission

Chien-Chun Hung, Yao-Jen Teng, Yung-Sheng Tien, Yu-Tsung Tsai

**Abstract**—Microstrip antennas are conformable to planar and nonplanar surfaces, simple and inexpensive to fabricate using modern printed-circuit technology. Circular polarization of low-profile microstrip patch with high bandwidth is achieved in this research through the use of a three-cross-arms branch-line coupler with sequential rotated arrays, another low-profile antenna of hollow cylinder is also proposed and the function of reconnaissance with microstrip antenna on Mini UAV (unmanned aerial vehicle) are evaluated in practical flight test.

**Keywords**—low-profile antenna, Mini UAV, reconnaissance

## I. INTRODUCTION

CONVENTIONAL onboard dipole/monopole antennas mounted on aircraft fuselage often lead to disturbances in aerodynamic field. In high-performance aircraft, spacecraft, and missile applications, where size, weight, performance, installation, and aerodynamics are of major constraints, low profile antennas such as microstrip antennas may be required. In order to meet the demands of long distance for aerospace communication, it is necessary to form an assembly of antenna elements in an electrical and geometrical array. And a high array factor will be obtained to enhance the performance of microstrip antenna if the right arrangement of phase array and choice of array elements have been accomplished, both planar antenna and cylindrical antenna arrays with coupled feeds on air substrates are also considered in this research. In order to reduce the aerodynamic drag, the antenna mounted on UAV fuselage should be low-profile. Moreover, to isotropically propagate an electromagnetic energy of equal amplitude in all directions to a far distance, this research also proposes a UAV antenna design with an omni-directional radiation patterns and higher radiation efficiency and antenna gain.

Chien-Chun Hung is with the Department of Mechatronic, Energy and Aerospace Engineering, Chung Cheng Institute of Technology, National Defense University, Taiwan, ROC (corresponding author to provide phone: +886-3-3800960 ext. 37; fax: +886-3-3895924; e-mail: hung@ndu.edu.tw).

Yao-Jen Teng is with the Doctoral Program, School of Defense Science, Chung Cheng Institute of Technology, National Defense University, Taiwan, ROC (e-mail: yaoyao174@yahoo.com.tw).

Yung-Sheng Tien is with the Master Program of Aerospace Engineering, Department of Mechatronic, Energy and Aerospace Engineering, Chung Cheng Institute of Technology, National Defense University, Taiwan, ROC (e-mail: c38523601@gmail.com).

Yu-Tsung Tsai is with the Master Program of Aerospace Engineering, Department of Mechatronic, Energy and Aerospace Engineering, Chung Cheng Institute of Technology, National Defense University, Taiwan, ROC (e-mail: clerk0621@gmail.com).

## II. LITERATURE REVIEWS

The concept of microstrip antenna can be traced back to 1953 [1] and a patent in 1955 [2]. However, microstrip antennas have not received considerable attention until the 1970s due to the development of printed-circuit technology, the improved photolithographic techniques, the availability of good substrates with low loss tangent (a quantity related to substrate loss due to dielectric damping) and attractive thermal and mechanical properties. Microstrip antennas have matured considerably during the past 30 years, and many of the limitations have been overcome. Recently, numerical simulations using moment methods and finite difference techniques have available, and the interesting development of microstrip antennas has been the use of active device integrated directly in the antenna structure [3]. Munson presented the microstrip antennas to form the feed network, radiators, and phase arrays [4]. Howell proposed the design procedures for both linearly and circularly polarized antennas [5]. Lo *et al.* developed a cavity model to analyze rectangular microstrip antennas and a formula for calculating the resonant frequency [6]. Derneryd *et al.* further developed the resonant cavity model to calculations losses, input conductance, and bandwidth of a rectangular microstrip antenna [7].

The above early works were based on simple transmission line or capacitance calculations, and the results were limited to simplified geometry. Hewman and Tulyathan proposed the method of moment based upon an integral equation formulation to analyze the current, impedance, and resonant frequency of a microstrip antenna [8]. Pozar introduced a new antenna configuration for improving performance of microstrip antennas and arrays [9]. Ke and Wong presented a full-wave analysis of the mutual coupling between two probe-fed rectangular microstrip antennas on a cylindrical body [10]. Antenna analysis was limited to geometries amenable to the solution of Maxwell's equation. Recently, numerical simulations using moment methods and finite difference techniques are available.

## III. DESIGN OF ANTENNAS

### A. Design of Microstrip Patch

The basic configuration of the microstrip antenna consists of a very thin metallic patch in a small fraction of one wavelength above the ground plane as shown in Fig. 1. There are numerous isotropic substrates that can be used for microstrip antennas and their dielectric constants ( $\epsilon_r$ ) are usually in the range of  $2.2 < \epsilon_r < 12$ . Thick substrates whose dielectric constant is in the lower end of the range are desirable because they provide better

efficiency, higher bandwidth, loosely bound fields for radiation into space, but at the expense of larger element size [11]. The microstrip feed line is also a conducting strip, usually of much smaller width compared to the patch. The microstrip feed line is easy to fabricate, simple to match by controlling the insert position. However, such feeds are thus limited in bandwidth to about 2-5% for practical purposes [12].

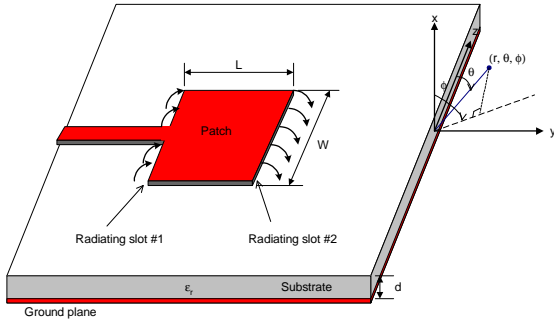

Fig. 1 Rectangular microstrip antenna

For the rectangular patch and coordinate system shown in Fig. 1, the lowest resonant frequency  $(f_r)_{010}$  for the dominant  $TM_{010}$  mode is given by [13]

$$(f_r)_{010} = \frac{V_c}{2L_{eff}\sqrt{\epsilon_{eff}}} = \frac{1}{2(L+2\Delta L)\sqrt{\epsilon_{eff}}\sqrt{\mu_0\epsilon_0}} \quad (1)$$

$$= q \frac{V_c}{2L\sqrt{\epsilon_r}},$$

where

$$\Delta L = 0.412d \frac{(\epsilon_{eff} + 0.3)\left(\frac{W}{d} + 0.264\right)}{(\epsilon_{eff} - 0.258)\left(\frac{W}{d} + 0.8\right)}, \quad (2)$$

$$\epsilon_{eff} = \frac{\epsilon_r + 1}{2} + \frac{\epsilon_r - 1}{2} \frac{1}{\sqrt{1 + 12d/W}} \quad \text{for } W/d > 1. \quad (3)$$

$V_c$  is the speed of light in free space,  $\mu_0 = 4\pi \times 10^{-7} H/m$  is the permeability of free-space,  $\epsilon_0 = \frac{1}{36\pi} \times 10^{-9} F/m$  is the permittivity of free-space,  $L$  is the physical length of the patch,  $W$  is the width of the patch,  $d$  is the thickness of the substrate,  $L_{eff}$  is the effective length of the patch,  $\Delta L$  is the extended incremental length due to fringing effects,  $q$  is the fringe factor or length reduction factor,  $\epsilon_r$  and  $\epsilon_{eff}$  are the relative and effective dielectric constants, respectively.

Consider the microstrip patch on the air substrate, the geometry could be simplified and given by

$$L = \frac{V_c}{2f_r\sqrt{\epsilon_{eff}}} \quad (4)$$

$$\epsilon_{eff} = 1 + \epsilon_r \left( \frac{h_1 - h_2}{h_2} \right) \quad (5)$$

where  $f_r$  is the resonant frequency,  $L$  is the physical length of

the patch,  $h_1$  is the total height of antenna,  $h_2$  is the thickness of air substrate,  $\epsilon_r$  and  $\epsilon_{eff}$  are the relative and effective dielectric constants, respectively. Two pieces of FR4 substrate ( $\epsilon_r = 4.4$ , loss tangent  $\tan \delta = 0.019$ ) with thickness of 0.4 mm are separate from 5.0 mm to stack as the antenna structure in Fig. 2.

Polarization of a radiated wave is defined as the property of an electromagnetic wave describing the time varying direction and relative magnitude of the electric-field vector. The polarization of an antenna in a given direction is defined as the polarization of the wave transmitted by the antenna. The sense of rotation for circular polarization (CP) is determined by observing the field rotation as the wave is viewed as it travels away from the observer. If the rotation is clockwise, the wave is right-hand circularly polarized (RHCP); if the rotation is counterclockwise, the wave is left-hand circularly polarized (LHCP). Circular polarization with only one feed can be achieved by a square patch with two truncated opposite corners, in order to achieve circular polarization, two opposite corners of this patch will be trimmed the right triangular truncation with base  $c$ .

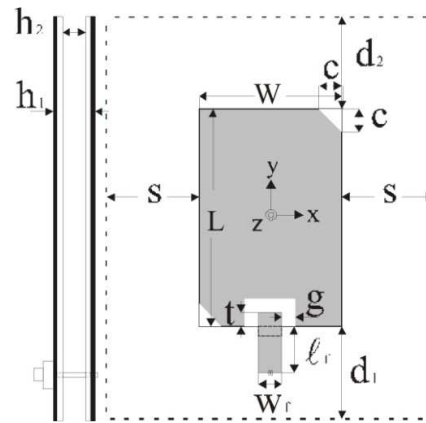

Fig. 2 Microstrip CP-patch with coupled feed

According to (4) and (5), the length of corner-truncated CP patch is  $L = 47 \text{ mm}$ , and the width of corner-truncated CP patch is  $W = L = 47 \text{ mm}$  as operating at  $f_r = 2.40 \text{ GHz}$ . After tuning the feeding network and geometry of ground plane, the return loss (RL) and axial ratio (AR) of this microstrip patch are shown in Fig. 3. According to Fig. 4, the measurement of radiation pattern shows the proposed antenna is right-hand circular polarization (RHCP), and the gain of this corner-truncated CP patch is about 9.0-9.2 dBic as shown in Fig. 5. The high gain will provide high quality for transmitting video signal and information as mounting on mini UAV with reconnaissance mission.

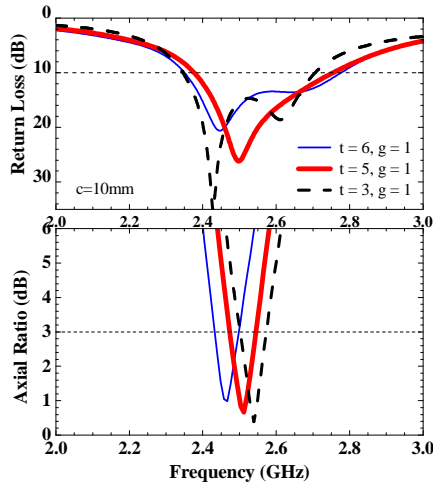

Fig. 3 Measured return loss and axial ratio of microstrip patch.

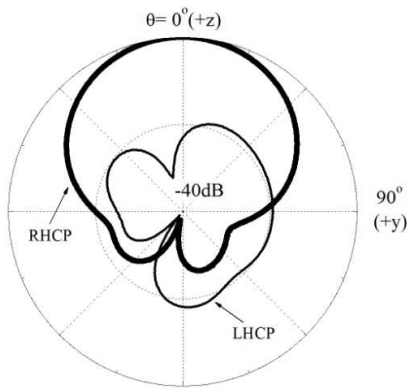

Fig. 4 Measured radiation pattern of microstrip patch

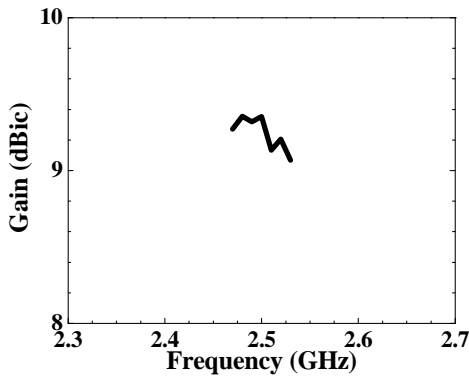

Fig. 5 Measured gain of microstrip patch

*B. Design of Antenna Array*

The idea of sequential rotated arrays dates back to the 1980s [14], which is designed by arranging antenna elements with different orientation angle. The sequential rotated arrays will improve bandwidth and gain of antennas [15-16]. As shown in Fig. 6, this research integrates the concept of three-cross-arms branch-line coupler [17] with sequential rotated arrays and CP patches of coupled feed. The measurement of return loss and axial ratio in Fig. 7 shows that the RL- and AR- bandwidth

increases 57% and 40% compared with Fig. 3, respectively, i.e., the proposed antenna possesses the better properties for transmitting signal.

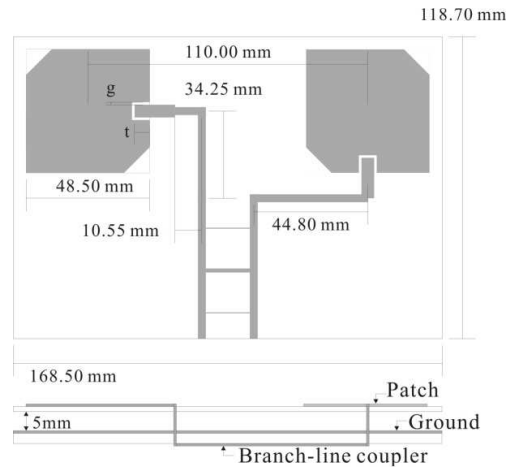

Fig. 6 Three-cross-arms branch-line coupler with both sequential rotated arrays and microstrip patch

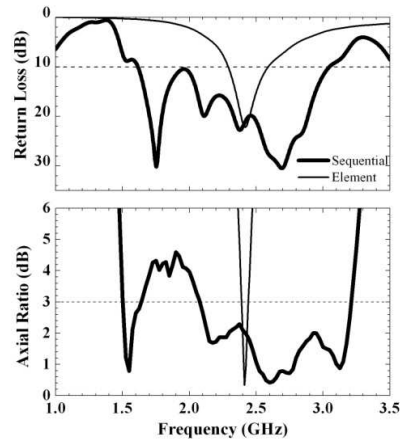

Fig. 7 Measured return loss and axial ratio of proposed antenna array with coupler

*C. Low Profile Omni-directional Antenna*

To meet the demands of long distance for aerospace communication, the antenna mounted on UAV fuselage should be low-profile. Moreover, to isotropically propagate an electromagnetic energy of equal amplitude in all directions to a far distance, this research will also propose a Mini UAV antenna design with an omni-directional radiation patterns and higher radiation efficiency and antenna gain. The preliminary design of low-profile omni-directional antenna on UAV is shown in Fig. 8. Antenna elements are connected with feed network and printed on the soft substrate, and revolved about the vertical axis circle to generate a cylinder.

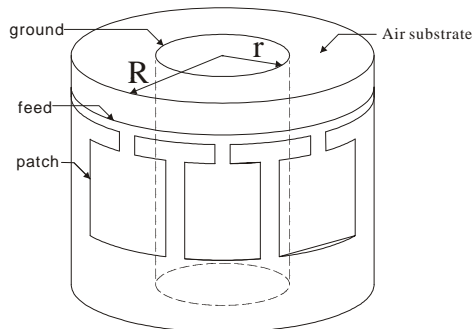

Fig. 8 Design of low-profile omni-directional antenna on UAV.

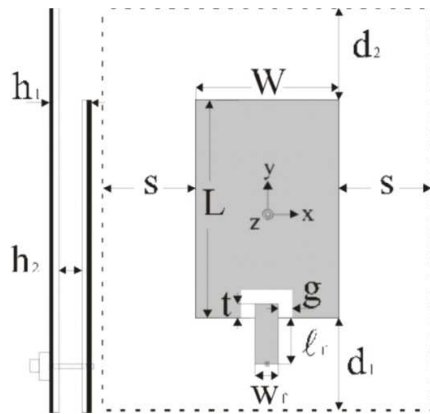

Fig. 9 Microstrip LP-patch with coupled feed

The linear polarized (LP) microstrip patch with coupled feed as shown in Fig. 9 is the element of  $1 \times N$  array to form the low-profile omni-directional antenna. Air substrate is used for low-profile omni-directional antenna in this research; however, high resistance and reactance due to air substrate should be considered. Hence, the antenna element should be designed to offset above drawbacks and for simple structure and small size. Fig. 9 shows that the proposed element of microstrip LP-patch is similar to Fig. 2, but two opposite corners not to be trimmed. Furthermore, there will be a compromise design between the numbers of antenna elements, beam width of antenna element and radius of cylinder, and so on [18-25].

The feed array of proposed low-profile antenna of  $1 \times 4$  array, as shown in Fig. 10, is designed on a circular substrate with radius of 40 mm. According to Fig. 12, the feed point A is the center of circular substrate and fed with a probe of 50 ohms. Points A and B will be linked with stretched microstrip lines with width of 0.3 mm and an angle of 125 deg., and there is a quarter-wave transformer of  $55.3 \text{ mm} \times 0.3 \text{ mm}$  from points B to C. Point C is also the junction of transformer and feed.

Similarly, the  $1 \times 6$  feed network of low-profile antenna is shown as Fig. 11 and designed to compromise the influence of arrangement and purpose of omni-directional radiation pattern. The measurement of return loss for  $1 \times N$  feed network is shown as Fig. 12, which indicates well impedance match on  $1 \times 4$  and  $1 \times 6$  feed networks. The difference on return loss, radiation pattern and gain of different arrays are shown as Figs. 13-15, respectively. The legend “planar element” means planar

antenna with coupled feed, “single element” means low-profile antenna with one antenna element only, “four elements” means low-profile antenna with  $1 \times 4$  array, and “six elements” means low-profile antenna with  $1 \times 6$  array, respectively.

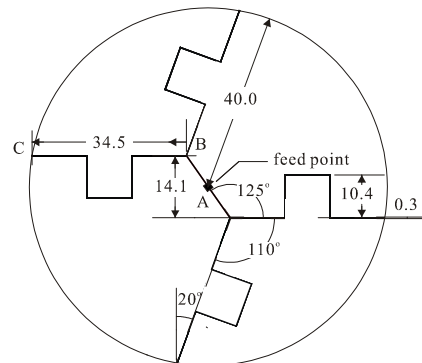
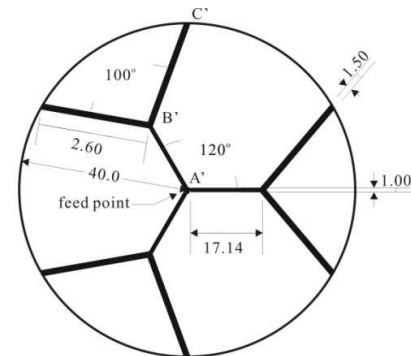
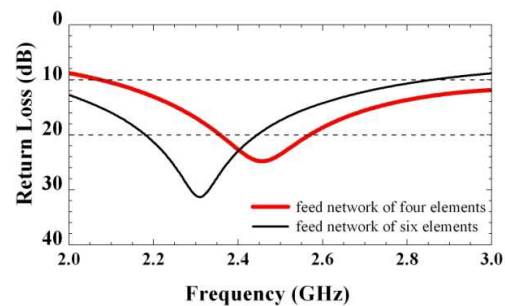
Fig. 10 Design of feed network of  $1 \times 4$  array.Fig. 11 Design of feed network of  $1 \times 6$  array.Fig. 12 Measured return loss for  $1 \times N$  feed network.

According to Fig. 14, the results show the radiation pattern is nearly omni-directional in low-profile antenna with  $1 \times 6$  array than low-profile antenna with  $1 \times 4$  array. The gain of  $1 \times N$  array in Fig. 15 is less than single planar element; that is, the power of low-profile antenna with  $1 \times N$  array has been divided into  $N$  antenna elements.

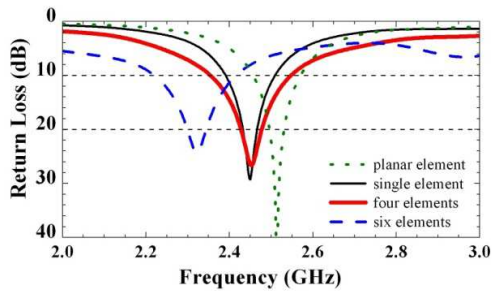
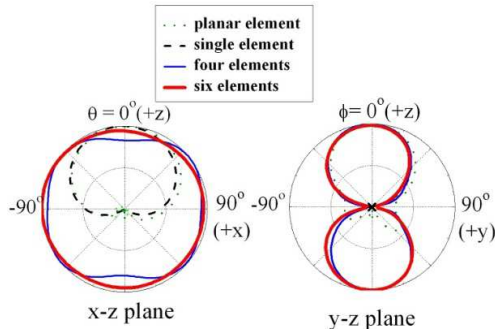
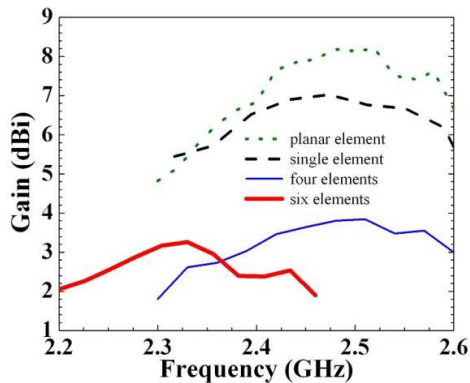
Fig. 13 Measured return loss for low-profile antenna of  $1 \times N$  array.Fig. 14 Radiation pattern for low-profile antenna of  $1 \times N$  arrayFig. 15 Gain for low-profile antenna of  $1 \times N$  array

#### IV. DESIGN OF "MONK VULTURE" MINI UAV

The proposed microstrip patch is mounted on "Monk Vulture" Mini UAV designed and fabricated by our own team [26]. The term "Mini UAV" means all the unmanned aerial vehicles with take-off weight of 5 to 50 pounds as categorized in Weibel's paper [27]. "Monk Vulture" is designed to search for the maximum amount of payloads that it can carry using the piston engine with 2.8 hp at 15,000 rpm assigned by the organizer. The proposed solution is that by moving the wing afterward on the fuselage of "TYLL-L" designed in 2009 [26] to have larger fuselage space to carry more dead weights. In order to acquaint enough lift at take-off, a canard is probably needed.

Another purpose of "Monk Vulture" is to use the fuselage of TYLL-L and modify its vertical tail to give sufficient directional stability. "Monk Vulture" still keeps its engine at the head and a possible three-surface configuration will be applied. The power effect on the longitudinal stability in

"Monk Vulture" could be negligible but the slipstream effect of propeller on the canard should not be forgotten.

To improve directional stability of TYLL-L and to carry more payloads, Monk Vulture has a similar shape, but with a canard, compared with TYLL-L. "Monk Vulture" is a traction-type engine propeller-driven air vehicle, and the proposed configuration is shown as Fig. 16.

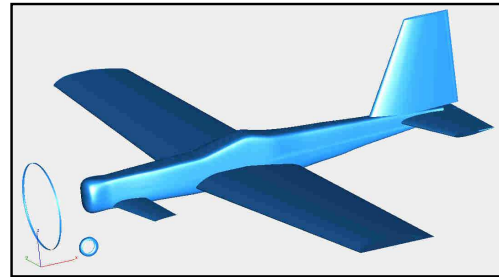

Fig. 16 The proposed 3-D configuration of "Monk Vulture" Mini UAV

#### V. CONCLUSION

This research applies 2.40 GHz wireless module to transmit video signal by using the proposed microstrip patch and antenna array with coupled feeds. The function of reconnaissance with low-profile antenna is proposed in this research, and the CCD (charge coupled device) camera is mounted to the UAV as photographic device. To integrate the CCD camera, wireless communication device and microstrip antenna into an innovative module is also the purpose of this research.

This research combines three-cross-arms branch-line coupler and corner-truncated CP patches, and shows that it could substantially increase RL- and AR- bandwidth of single microstrip patch to 57% and 40%, respectively. And another low-profile antenna with  $1 \times N$  array is also proposed to meet the demands of aerospace communication with reconnaissance mission.



Fig. 17 "Monk Vulture" Mini UAV Flying on Hsisheng Airport along the Tahan Creek near Taipei.

Fig. 17 shows a photo as "Monk Vulture" Mini UAV flying in the sky. Fig. 18 indicates one captured picture from video



signal during UAV-flight on Hsisheng Airport along the Tahan Creek near Taipei; that is, this research also successfully tests and verifies transmission reconnaissance signal with proposed microstrip patch and low-profile antenna mounted on Mini UAV in practical flight test.



Fig. 18 One captured picture during UAV-flight on Hsisheng Airport

#### ACKNOWLEDGMENT

This work was supported in part by the National Science Council, Taiwan, ROC under NSC 100-2221-E-606-011.

#### REFERENCES

- [1] G. A. Deschamps, "Microstrip Microwave Antennas," *presented at the USAF Symposium on Antennas*, 1953.
- [2] H. Gutton and G. Baissinot, "Flat Aerial for Ultra High Frequency," *French Patent No. 703 113*, 1955.
- [3] S.-Y. Lin and H.-R. Chuang, "Design of 2.4 GHz LNA/PA/Circularly-Polarized Active Microstrip Antennas," *Microwave Journal*, vol. 42, no. 1, pp. 22-37, Jan. 1999.
- [4] R. E. Munson, "Conformal Microstrip Antennas and Microstrip Phased Arrays," *IEEE Trans. Antennas and Propagation*, vol. AP-27, pp. 74-78, Jan. 1974.
- [5] J. Q. Howell, "Microstrip Antennas," *IEEE Trans. Antennas Propagat.*, vol. AP-23, pp. 90-93, Jan. 1975.
- [6] Y. T. Lo, D. Solomon, and W. F. Richards, "Theory and Experiment on Microstrip Antennas," *IEEE Trans. Antennas Propagat.*, vol. AP-27, no. 2, pp. 137-145, Mar 1979.
- [7] A. G. Derneryd and A. G., "Extended Analysis of Rectangular Microstrip Resonator Antennas," *IEEE Trans. Antennas Propagat.*, vol. AP-27, no. 6, pp. 846-849, Nov. 1979.
- [8] E. H. Hewman and P. Tulyathan, "Analysis of Microstrip Antennas Using Moment Method," *IEEE Trans. Antennas Propagat.*, vol. AP-29, no. 1, pp. 47-53, Jan. 1981.
- [9] D. M. Pozar, "Microstrip Antennas," *Proc. IEEE*, vol. 80, no. 1, pp. 79-81, Jan. 1992.
- [10] K. Y. Ke and K. L. Wong, "Mutual Coupling between Cylindrical-Rectangular Microstrip Antennas," *IEEE Trans. Antennas and Propagation Society International Symposium, AP-S. Digest*, vol. 1, pp. 194-197, Jan. 1994.
- [11] I. J. Bahl, P. Bhartia, and S. S. Stuchly, "Design of Microstrip Antennas Covered with a Dielectric Layer," *IEEE Trans. Antennas Propagat.*, vol. AP-30, no. 2, pp. 314-318, Mar 1982.
- [12] D. M. Pozar, "Radiation and Scattering from a Microstrip Patch on a Uniaxial Substrate," *IEEE Trans. Antennas Propagat.*, vol. AP-35, no. 6, pp. 613-621, Jun 1987.
- [13] D. M. Pozar, "Microstrip Antennas," *Proc. IEEE*, vol. 80, no. 1, pp. 79-81, Jan. 1992.
- [14] T. Teshirogi, M. Tanaka, and W. Chujo, "Wideband Circularly Polarized Array Antenna with Sequential Rotations and Phase Shift of Elements," *Proceedings of International Symposium on Antennas and Propagation*, pp. 117-120, Japan 1985.
- [15] J. Huang, "A Technique for an Array to Generate Circular Polarization with Linearly Polarized Elements," *IEEE Trans. Antennas Propagat.*, vol. 34, pp. 1113-1124, 1986.
- [16] P. S. Hall, J. S. Dabele, and J. R. James, "Design Principles of Sequentially Fed, Wide Bandwidth, Circularly Polarized Microstrip Antennas," *IEEE Proc. H.*, vol. 136, pp. 381-389, 1989.
- [17] C.-M. Chang, K.-Y. Chiang, Y.-C. Lu, Y.-J. Teng, H.-C. Ping, K.-C. Liu, C.-H. Lin, and C.-C. Hung, "Design and Fabrication of High-payload UAV with Reconnaissance Mission," *presented at the AASRC/CCAS Joint Conference*, Taipei, Taiwan, Dec. 2009.
- [18] K. L. Wong, W. H. Hsu, and C. K. Wu, "Single-feed Circularly Polarized Microstrip Antenna with a Slit," *Microwave Opt. Technol. Lett.*, vol. 18, pp. 306-308, Jul. 1998.
- [19] H. M. Chen and K. L. Wong, "On Circular Polarization Design of Annular-ring Microstrip Antennas," *IEEE Trans. Antennas Propagat.*, vol. 47, pp. 1289-1292, Aug. 1999.
- [20] K. L. Wong and J. Y. Wu, "Single-feed Small Circularly Polarized Square Microstrip Antenna," *Electron Lett.*, vol. 33, pp. 1833-1834, Oct. 1997.
- [21] K. L. Wong and M. H. Chen, "Single-feed Small Circular Microstrip Antenna with Circular Polarization," *Microwave Opt. Technol. Lett.*, vol. 18, pp. 394-397, Aug. 1998.
- [22] K. L. Wong and Y. F. Lin, "Circularly Polarized Microstrip Antenna with a Tuning Stub," *Electron Lett.*, vol. 34, pp. 831-832, Apr. 1998.
- [23] W. S. Chen, C. K. Wu, and K. L. Wong, "Square-ring Microstrip Antenna with a Cross Strip for Compact Circular Polarization Operation," *IEEE Trans. Antennas Propagat.*, vol. 47, pp. 1566-1568, Oct. 1999.
- [24] W. S. Chen, C. K. Wu, and K. L. Wong, "Novel Compact Circularly Polarized Square Microstrip Antenna," *IEEE Trans. Antennas Propagat.*, vol. 49, pp. 340-342, Mar. 2001.
- [25] W. S. Chen, C. K. Wu, and K. L. Wong, "Compact Circularly Polarized Circular Microstrip Antenna with Cross Slot and Peripheral Cuts," *Electron Lett.*, vol. 34, pp. 1040-1041, May 1998.
- [26] C.-C. Hung, C.-H. Lin, Y.-J. Teng, C.-M. Chang, and Y.-K. Wu, "Study on Mini UAV Designs to Payload Requirements by Airplane Sizing Methodology," *presented at the AIAA Infotech@Aerospace - 2010 Conference and Exhibit*, AIAA Paper 2010-3507, Atlanta, Georgia, USA, Apr. 2010.
- [27] R. E. Weibel, and R. J. Hansman, Jr., "Safety Considerations for Operation of Different Classes of UAVs in the NAS," *presented at the AIAA 3<sup>rd</sup> "Unmanned Unlimited" Technical Conference, Workshop and Exhibit*, Chicago, Illinois, USA, Sep. 2004.

**Chien-Chun Hung** was born in Tainan, Taiwan in 1969. He received the B.S. degree in aeronautical engineering from Chung Cheng Institute of Technology, Taoyuan, Taiwan, in 1992, the M.S. degree in mechanical engineering from Tamkang University, Taipei, Taiwan, in 1996, and the Ph.D. degree in aeronautics and astronautics from National Cheng Kung University, Tainan, Taiwan, in 2004. From 1992 to 1994, he was a Teaching Assistant with the Department of Aeronautical Engineering, Chung Cheng Institute of Technology, Taoyuan, Taiwan. Since 1996, he has been a Lecturer with the Department of Aeronautical Engineering, Chung Cheng Institute of Technology. From 1999 to 2006, he was also a Patent Referee with Intellectual Property Office of Taiwan. He became an Associate Professor with the same department in 2004, and he also served as Chairman of the Aeronautical Engineering Department from 2005 to 2006. From Nov. 2006 to now, he is an Associate Professor with the Department of Mechatronic, Energy and Aerospace Engineering, Chung Cheng Institute of Technology, National Defense University, Taoyuan, Taiwan. His current research interests are in the area of aeroelasticity, structural dynamics, optimum design, microstrip antenna, composite materials, and UAV design.