

Stability Analysis of Single Inverter Fed Two Induction Motors in Parallel

R. Gunabalan, V. Subbiah

Abstract—This paper discusses the novel graphical approach for stability analysis of multi induction motor drive controlled by a single inverter. Stability issue arises in parallel connected induction motors under unbalanced load conditions. The two powerful globally accepted modeling and simulation software packages such as MATLAB and LabVIEW are selected to perform the stability analysis. The stability investigation is performed for different load conditions and difference in stator and rotor resistances among the two motors. It is very simple and effective than the techniques presented to obtain the stability of the parallel connected induction motor drive under unbalanced load conditions. Approximate transfer functions are considered to model the induction motors, load dynamics, speed controllers and inverter. Simulink library tools are utilized to model the entire drive scheme in MATLAB. Stability study is discussed in LabVIEW using control design and simulation toolkits. Simulation results are illustrated for various running conditions to demonstrate the effectiveness of the transfer function method.

Keywords—Induction motor, Modeling, Stability analysis, Transfer function model.

I. INTRODUCTION

INDUCTION motors are widely used in industries because of its simple construction, low cost and less maintenance. In electric traction drives, induction motors are connected in parallel and powered by a single inverter to reduce the size, cost and also for less maintenance. State space model of parallel connected induction motor drives were discussed in many research papers and MATLAB/Simulink was used for modeling [1], [2]. Unbalance load condition arises in parallel operated drives whenever there is a change in wheel diameter or motor slip-torque characteristics [3]. Under such conditions, the speed of the motor which draws less current increased continuously and the speed of the motor which draws large current decreased. This makes the system unstable and is mandatory to know the stability of the drives for unbalanced load conditions. It is very difficult as it involves the blocks of inverter, speed and current controller, induction motors, transformation in different reference frame etc. To make the system stable, different control methodologies were presented [4]–[7] but stability of the system was not proved.

Stability is usually the most important attribute to be determined for drive systems. For linear systems, Routh stability criterion and Nyquist stability criterion are applicable.

Gunabalan R. is with the Department of Electrical and Electronics Engineering, Chandy College of Engineering, Thoothukudi, Anna University, Chennai, Tamil Nadu, India (e-mail: gunabalan@yahoo.co.in)

Subbiah V. is with the Department of Electrical and Electronics Engineering, PSG College of Technology, Coimbatore, Anna University, Chennai, Tamil Nadu, India (e-mail: subbiah42@yahoo.com)

For nonlinear systems, phase plane and describing function method are preferred. Much of the stability analysis is done by computer simulation. Non-linear and time varying systems, stability analysis is performed by Lyapunov's method and it is difficult to construct Lyapunov's function.

Routh–Hurwitz criterion was used in [8] for stability analysis of three phase induction motor drive in which the observer gain constant k is designed to make the system stable under very low speed region. The complete stability of full order and reduced order observers for all operating conditions including regeneration mode and low speed regions are reported by Lennart Harnefors and Marko Hinkkanen [9]. In the conventional speed adaptation law, $\phi = 0$, system is unstable under low speed regeneration mode [10] and the problem is overcome by calculating ϕ accordingly. P. Vaclavek and P. Blaha proposed [11] Lyapunov function based flux and speed observer for sensorless control and parameter estimation of induction motor. In literature [8]–[11], stability analysis is performed in different operating regions for single three phase induction motor drive controlled by an inverter. Stability analysis is not performed for multiple induction motors connected in parallel and fed by a single inverter.

In this paper, transfer function approach is used to model two induction motors controlled by a single inverter in MATLAB. The stability of the drive system is proved with graphical approach for different operating conditions in LabVIEW. The paper is organized as follows: Chapter II discusses the transfer function modeling of parallel connected induction motor drive. Chapter III focuses on the design of speed controllers, inverter, feed-back, and gain blocks. Chapter IV presents the simulation results in MATLAB and its validation for different running conditions. Stability analysis is performed in LabVIEW for similar and dissimilar motor parameters in Chapter V. Finally it is concluded in Chapter VI.

II. MODELING OF PARALLEL CONNECTED VECTOR CONTROLLED INDUCTION MOTOR DRIVE

The configuration of the vector controlled parallel connected induction motor drive is shown in Fig. 1. With the measured speeds of both motors, torque reference is calculated from the speed error using P-I controllers. The stability analysis of multi-motor drive is performed by transfer function approach [12]. It is derived under the assumption of constant rotor flux linkages. It is derived by applying the transfer functions of various subsystems, such as the induction motor, inverter, speed controllers and feedback elements. The transfer

functions of various subsystems are represented as follows: The q-axis stator current which produces the electromagnetic torque is derived from the d-q model of the induction motor.

$$i_{qs}^e = \frac{K_a}{1+sT_a} \{V_{qs}^e - \omega_r L_s i_{ds}^e\}$$

where

$$K_a = \frac{1}{R_a}, L_a = L_s - \frac{L_m^2}{L_r}, T_a = \frac{L_a}{R_a}, R_a = R_s + \frac{L_s}{L_r} R_r$$

The expression for electromagnetic torque is given as

$$T_e = K_T i_{qs}^e$$

where K_T is the torque constant

$$K_T = \frac{3}{2} \frac{P}{L_r} \frac{L_m^2}{L_r} i_{ds}^e$$

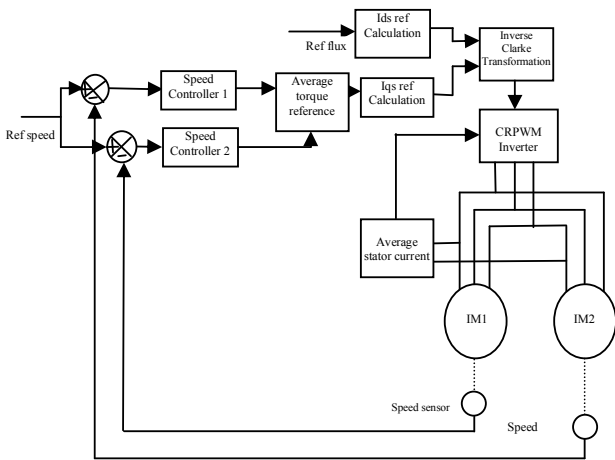

Fig. 1 Block diagram of parallel connected induction motor drive

A PI controller is used to process the speed error and generates the required torque reference. The transfer function of PI speed controller is obtained as

$$\frac{K_s(1+ST_s)}{ST_s} \tag{4}$$

The inverter is a sampled data system and the transfer function of the inverter is represented by a gain K_{in} with a delay time of T_{in} . The gain is obtained from the given DC input voltage and the delay time is equal to the average carrier switching cycle time. Thus, the transfer function of the inverter is

$$\frac{K_{in}}{1+ST_{in}} \tag{5}$$

where

$$K_{in} = 0.65 * \frac{V_{DC}}{V_{cm}} \tag{6}$$

$$T_{in} = \frac{T_c}{2} = \frac{1}{2f_c} \tag{7}$$

$$V_{DC} = \frac{V_{LL1} (rms)}{ma * 0.612} \tag{8}$$

Transfer function of motor load is

$$\frac{1}{B+SJ} \tag{9}$$

- (1) The overall block diagram of the vector control induction motor drive is obtained by combining the subsystem blocks. The reference speed which is common to both induction motors is compared with the actual running speed. The speed error is processed in the PI controller and the torque reference is developed from the average output of the PI controller. Fig. 2 depicts the transfer function model of induction motor drive connected in parallel and fed by a single inverter.
- (2)

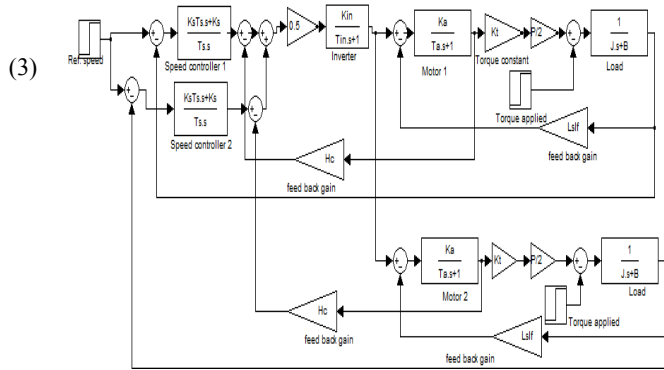

Fig. 2 Transfer function model of parallel connected induction motor drive in MATLAB

III. DESIGN OF SPEED CONTROLLERS

The speed controllers for motor 1 and motor 2 are designed based on the performance parameters and ratings of the induction motors. Table I presents the ratings of the three phase squirrel cage induction motor. The rating of both motors remains identical.

TABLE I
RATING AND PARAMETERS OF INDUCTION MOTOR

Motor rating	
Output	745.6 W
Poles	4
Speed	1415 rpm
Voltage	415 V
Current	1.8 A
R_s	19.355 Ω
R_r	8.43 Ω
L_s	0.715 H
L_r	0.715 H
L_m	0.689 H
f	50 Hz
J	0.0596 kg/m ²
B	0.05

Substituting the rating of the induction motor in (1) to (9), the transfer function of the motor and inverter are obtained as follows:

$$R_a = R_s + \frac{L_s}{L_r} R_r; R_a = 27.785 \Omega$$

$$K_a = \frac{1}{R_a} = 0.036 \text{ U}$$

$$L_a = L_s - \frac{L_m^2}{L_r} = 0.051 \text{ H}$$

$$T_a = \frac{L_a}{R_a} = 1.835 * 10^{-3} \text{ s}$$

Thus, the transfer function of the induction motor is

$$\frac{K_a}{1 + sT_a} = \frac{0.036}{1 + 0.001835s}$$

The inverter carrier frequency is assumed as 2000 Hz.

$$f_c = 2000 \text{ Hz}$$

$$T_{in} = \frac{T_c}{2} = \frac{1}{2f_c} = 0.00025 \text{ s}$$

$$K_{in} = 0.65 * \frac{V_{DC}}{V_{cm}}$$

$$V_{cm} = 10 \text{ V}$$

$$V_{LL1(rms)} = 415 \text{ V}$$

$$V_{DC} = \frac{V_{LL1(rms)}}{m_a}$$

For a modulation index of $m_a = 0.8$, $V_{DC} = 848 \text{ V}$

$$K_{in} = 55.12$$

The transfer function of the inverter is

$$\frac{K_{in}}{1 + sT_{in}} = \frac{55.12}{1 + 0.00025s}$$

The speed controller gain constant K_s and the time constant T_s are determined by finding the approximate inner current loop and inverter transfer function parameters.

$$T_s = 6T_{wi}$$

$$T_{wi} = T_w + T_i$$

$$T_i = T_1$$

where, T_1 is one of the roots of the approximate transfer function in the inner current loop.

$$T_1 = 0.001257 \text{ s}$$

It is assumed that the value of $T_w = 0.002 \text{ s}$

$$\text{thus, } T_{wi} = 0.003257 \text{ s}$$

$$T_s = 6T_{wi} = 0.0195 \text{ s}$$

$$K_s = \frac{4}{9K_g T_{wi}}$$

where,

$$K_g = \frac{K_i K_m H_w}{T_m}$$

$$K_m = \frac{P K_t}{2 B}$$

$$K_t = \frac{3 P L_m^2}{2 L_r} i_{ds}$$

i_{ds} is the flux producing current and is determined from d-q machine model. The value of i_{ds} is 1.062A.

thus, $K_t = 2.115 \text{ Nm/A}$

$$K_m = \frac{P K_t}{2 B} = 84.6$$

$$T_m = \frac{J}{B} = 1.192 \text{ s}$$

$$K_i = \frac{K_{in}}{R_a} = 1.984$$

It is assumed that the value of $H_w = 0.05$

$$K_g = \frac{K_i K_m H_w}{T_m} = 7.04$$

$$K_s = \frac{4}{9K_g T_{wi}} = 19.38$$

Thus the transfer function of PI speed controller is derived as

$$\frac{19.38(1 + 0.0195s)}{0.0195s}$$

The transfer function of the mechanical system is

$$\frac{1}{B + sj} = \frac{1}{0.05 + 0.0596s}$$

The transfer function model of the parallel connected induction motor drive is constructed after obtaining the transfer function of various blocks.

IV. MATLAB VALIDATION

To validate the effectiveness of the transfer function model, the speed responses are obtained under a variety of operating conditions. In the balanced load test, a load of 2 Nm is applied to both induction motors at $t=2\text{s}$ and the reference speed is set at 1200 rpm. The speed response is shown in Fig. 3 and it is viewed that both motors follow the speed command with zero steady state error. It is similar to the response obtained from the induction motor state space model with speed estimation and load torque adaption [13].

In the unbalanced load test, a load of 2.5 Nm is applied to motor 1 and motor 2 is at no load condition. The speed responses of both motors deviate from the reference speed by 72 rpm however speed remains invariable. This is illustrated in Fig. 4 and it implies that the system remains stable under unequal load conditions.

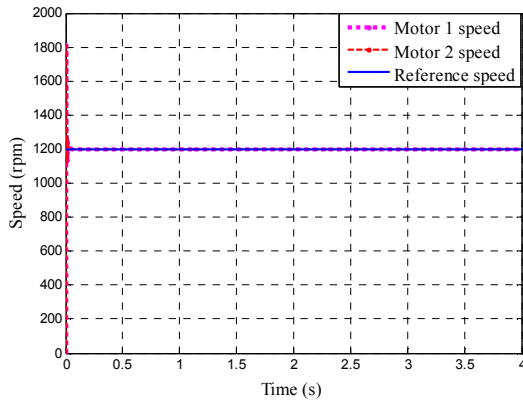

Fig. 3 Speed response under balanced load conditions

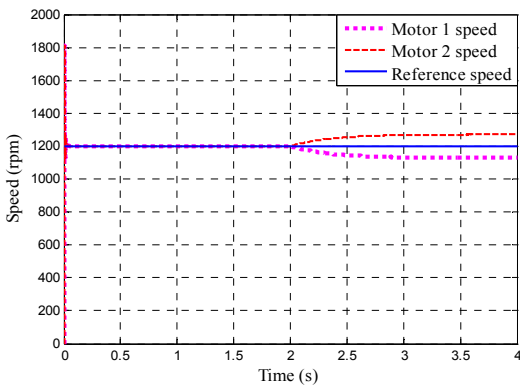

Fig. 4 Speed response under unbalanced load conditions

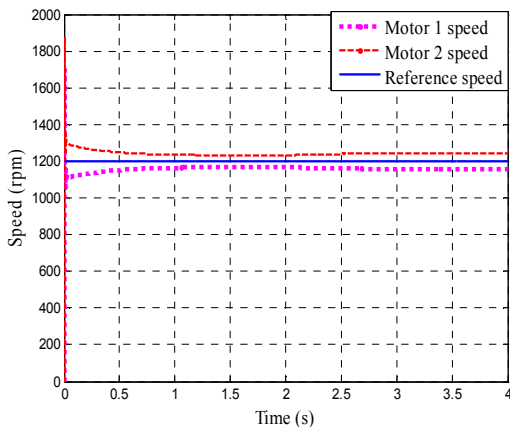

Fig. 5 Speed responses of induction motors for 25% increase in stator resistance of motor 1 with balanced load

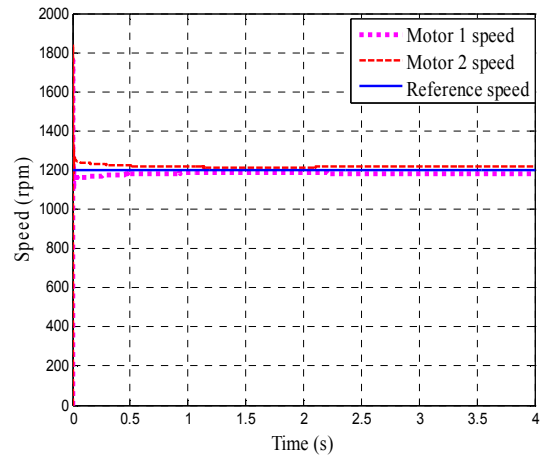

Fig. 6 Speed responses of induction motors for 25% increase in rotor resistance of motor 1 with balanced load

To accommodate the change in parameter, the stator resistance of motor 1 is increased by 25% and other running conditions remain the same. Reference speed is set at 1200 rpm and both the motors are initially at no load condition. At no load, the speeds of both motors move away from the reference speed by 31 rpm. At $t = 2$ s, a balanced load of 2.5 Nm is applied to both motors. Fig. 5 shows the speed response of motor 1 and motor 2. It is observed that the speed of motor 2 increases to 1243 rpm and the speed of motor 1 decreases to 1157 rpm referred to the command speed. The speed difference between the two motors is 86 rpm (7.16%). In case of balanced load with equal value of stator resistances, the speed difference between the motors under steady state is zero.

Fig. 6 shows the speed response of motor 1 and motor 2 for mismatch in rotor resistances. At no load, the speeds of both motors deviate from the reference speed by 14 rpm. At balanced load, the speed of motor 2 increases to 1219 rpm and the speed of motor 1 decreases to 1181 rpm referred to the command speed. The speed difference between the two motors is 38 rpm (3.16%).

V. LABVIEW BASED STABILITY ANALYSIS

The speed responses are attained for unequal load conditions and it is experiential that the system is stable. After validated in MATLAB Simulink, the stability of the drive system is performed in LabVIEW (Laboratory Virtual Instrumentation Engineering Workshop) environment. Control design and simulation VIs (virtual instrumentation) in LabVIEW [14] are required to frame the transfer function of various sub-blocks. CD series.vi, CD add.vi, CD subtract.vi, CD stability.vi, gain and display blocks are used to construct the transfer function model in Lab-VIEW. The stability of the system is proved under unbalanced load conditions and also confirmed for 25% different in rotor and stator resistance of motor 1 and motor 2. The corresponding front panel representation is shown in Figs. 7 and 8 respectively.

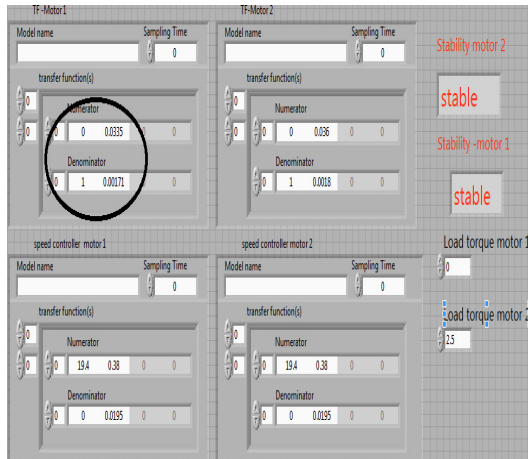

Fig. 7 Front panel representation for stability analysis of parallel connected induction motor drive for 25% increase in rotor resistance of motor 1



Fig. 8 Front panel representation for stability analysis of parallel connected induction motor drive for 25% increase in stator resistance of motor 1

VI. CONCLUSION

The stability analysis of single inverter fed two induction motors operated in parallel based on transfer function graphical approach is conferred for different running conditions. The entire drive system is modeled by transfer function concepts in MATLAB and their performance are simulated for a range of operating states. The stability of the multi motor drive (2 motors) is proved graphically in LabVIEW for balanced, unbalanced, mismatch in stator and rotor resistances. The speed deviation exists between the induction motors because the average parameters are considered and differential parameters are not used. The method is very simple and complicated d-q model is not required.

REFERENCES

- [1] G K.Matsuse, Y.Kouno, H.Kawai, J.Oikawa, "Characteristics of speed sensor-less vector controlled dual induction motor drive connected in parallel fed by a single Inverter", IEEE Trans. Ind. Appl., vol. 40, pp. 153-161, Jan./Feb. 2004.
- [2] Wang Ruxi, Wang Yue, Dong Qiang He Yanhui and Wang Zhaoan, "Study of control methodology for single inverter parallel connected dual induction motors based on the dynamic model", IEEE PESC'06, 2006.
- [3] B. K. Bose, "Modern Power Electronics and AC Drives", Upper Saddle River, NJ: pp.348-350, Prentice-Hall, 2001.
- [4] Yoshinaga T., Terunuma T. and Matsuse K., "Basic characteristic of parallel connected dual induction motor drives with matrix converter", In: Proceedings of 34th Annual conference of IEEE Ind. Electronics, 2008, pp.584-589.
- [5] Osawa A., Yamazaki M. and Matsuse K., "Vector control method of parallel connected induction motor drives fed by a matrix converter", In: Proceedings of IEEE IAS meeting, Oct. 2011.
- [6] Osawa A., Yamazaki M. and Matsuse K., "Vector control method and driving characteristics of parallel connected induction motor drives fed by a matrix converter", In: Proceedings of IEEE power engineering conference, 2011.
- [7] Masao Yano, Satoru Kuramoto and Hiroyuki Matsuda, "Vector control method of parallel connected induction motors", Electrical engineering report, pp. 34-39, NR-12, Nov.2001.
- [8] H. Kubota, I.Sato, Y. Tamura, K.Matsuse, H. Ohta and Y. Hori, "Regenerative mode low speed operation of induction motor drive with adaptive observer", IEEE Trans. Ind. Appl., vol.38, no.4, pp.1081-1086, July/Aug. 2002.
- [9] Lennart Harnefors Marko Hinkkanen, "Complete stability of reduced-order and full-order observers for sensorless IM drives", IEEE Trans. Ind. Electron., vol. 55, no. 3, pp.1319-1329, March 2008.
- [10] Hisao Kubota, Kouki Matsuse and Takayoshi Nakano, " DSP-based speed adaptive flux observer of induction motor", IEEE Trans. Ind. Appl., vol. 29, no. 2, pp.344-348, March/April 1993.
- [11] P. Vaclavek and P. Blaha, "Lyapunov function based flux and speed observer for AC induction motor sensorless control and parameter estimation", IEEE Trans. Ind. Electron., vol. 53, no.1, Feb. 2006.
- [12] R. Krishnan, "Electric motor drives modeling, analysis and control", pp. 492-501, PHI learning private limited, New Delhi, 2001.
- [13] R. Gunabalan, V. Subbiah, "Speed sensorless vector control of parallel connected induction motor drive with fuzzy controller", In: Proceedings of IEEE conference (ICCC'12), 2012, pp. 473-478.
- [14] Lab-view control design user manual, National Instruments, 2008.



Gunabalan R obtained his B.E. degree in Electrical and Electronics Engineering from Manonmanium Sundaranar University, TamilNadu in 2000 and M.Tech.degree in Electrical Drives & Control from Pondicherry University in 2006. He is currently pursuing his Ph.D from Anna University, Chennai, TamilNadu.

He is working as an Assistant Professor in the department of Electrical and Electronics Engineering, Chandy College of Engineering, Thoothukudi, TamilNadu, India. His research interests are in the areas of power electronics and estimation and control of motor drives.

Mr. Gunabalan R is a life member of ISTE.



Dr Subbiah V obtained his BE (Electrical) degree from Madras University, India in 1965, ME (Control Systems) from Calcutta University in 1968 and PhD (Power Electronics) from Madras University in 1981.

He has been associated with Technical Education for more than four decades. He worked at PSG College of Technology, Coimbatore, India in various capacities and retired in May 2000. Then, he joined the Faculty of Engineering, Multimedia University, Malaysia in June 2000 on a contract appointment for two years. After returning to India, he joined Sri Krishna College of Engineering and Technology, Coimbatore in August 2002 as the Dean of Electrical Sciences and continued in that capacity till 2013. Currently, he is working as a visiting professor at PSG College of Technology, Coimbatore. He has taught undergraduate as well as postgraduate courses for more than 40 years. He has published / presented around 80 papers in National and International Journals / Conferences. His area of interest includes Power Electronics, Electrical Drives and Control Systems.

Dr. Subbiah V is a Fellow of the Institution of Engineers (India) and a Life Member of ISTE.