

Current Controlled Current Conveyor (CCCII) and Application using 65nm CMOS Technology

Zia Abbas, Giuseppe Scotti and Mauro Olivieri

Abstract—Current mode circuits like current conveyors are getting significant attention in current analog ICs design due to their higher band-width, greater linearity, larger dynamic range, simpler circuitry, lower power consumption and less chip area. The second generation current controlled conveyor (CCCII) has the advantage of electronic adjustability over the CCII i.e. in CCCII; adjustment of the X-terminal intrinsic resistance via a bias current is possible. The presented approach is based on the CMOS implementation of second generation positive (CCCII+), negative (CCCII-) and dual Output Current Controlled Conveyor (DOCCCII) and its application as Universal filter. All the circuits have been designed and simulated using 65nm CMOS technology model parameters on Cadence Virtuoso / Spectre using 1V supply voltage. Various simulations have been carried out to verify the linearity between output and input ports, range of operation frequency, etc. The outcomes show good agreement between expected and experimental results.

Keywords—CCCII+, CCCII-, DOCCCII, Electronic tunability, Universal filter

I. INTRODUCTION

CURRENT conveyor is a versatile current mode circuit, gaining acceptance as both a theoretical and practical building block. The current conveyor, with one high impedance input, one low impedance input and one high impedance output is a suitable element for both voltage-mode and current-mode circuits. The classical op-amps suffer from limited gain-bandwidth product problems and from low slew rate at its output. So, they remain unsatisfactory at higher frequencies. Moreover supply voltage has become the great concern in present electronic circuit design scenario especially for portable and battery powered equipment and the breakdown voltage of short channel MOS transistors. Since a low-voltage operating circuit becomes necessary, current-mode techniques are better suited for such purposes in comparison with voltage-mode ones. Consequently, current-mode circuits are receiving significant attention due to their larger dynamic range, higher band-width, greater linearity, simpler circuitry, lower power consumption, and reduced chip area as compared to their voltage mode counterparts like Operational Amplifiers. In recent years, due to the integration suitability with CMOS technology, current mode devices are finding even more consideration in circuit designs [1,2].

Zia Abbas is with Department of Information, Electronics and Telecommunication Engineering (DIET), Sapienza University of Rome, Rome, Italy (abbas@die.uniroma1.it).

Giuseppe Scotti is with Department of Information, Electronics and Telecommunication Engineering (DIET), Sapienza University of Rome, Rome, Italy (scotti@die.uniroma1.it).

Mauro Olivieri is with Department of Information, Electronics and Telecommunication Engineering (DIET), Sapienza University of Rome, Rome, Italy (olivieri@die.uniroma1.it).

II. DESCRIPTION OF CURRENT CONTROLLED CONVEYORS

Fig. 1 and Fig. 2 show the symbol and equivalent circuit of the second generation Current Controlled Conveyor (CCCII). A CCCII-based circuit, whether positive, negative or dual output [3], provides electronic tunability and wide tunable range of its resistance at X-terminal [6]. The CCCII requires no external resistors; hence it is very suitable in the design of integrated filters and oscillators. Also, as the CCCII is current controlled current source, the CCCII based circuit is very suitable for high frequency operation. These features are very attractive to circuit designers [4].

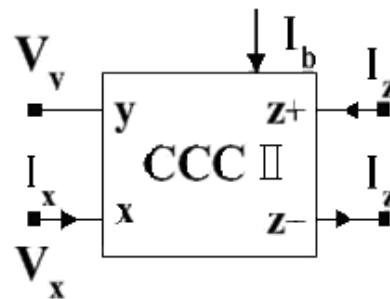

Fig.1: Symbol for CCCII

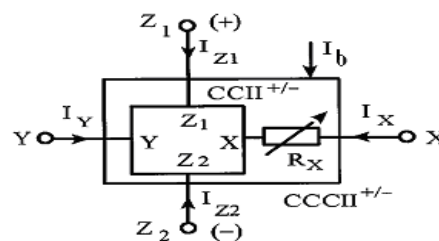

Fig.2 Equivalent Circuit Diagram of CCCII

The relationship between the voltage and current variables at input and output ports X, Y and Z of the CCCII can be expressed by the following matrix,

$$\begin{bmatrix} V_x \\ I_y \\ I_z \end{bmatrix} = \begin{bmatrix} R_x & 1 & 0 \\ 0 & 0 & 0 \\ \pm 1 & 0 & 0 \end{bmatrix} \begin{bmatrix} I_x \\ V_y \\ V_z \end{bmatrix} \quad (1)$$

where the sign \pm refers to plus-type or minus-type CCCII, respectively, and R_x denotes the intrinsic resistance at X terminal. R_x is adjustable by a supplied bias current I_b which can be expressed through a class AB trans-linear loop, which is used as input section.

$$I_y = 0 \tag{2}$$

$$V_x = V_y + I_x R_x \tag{3}$$

$$I_{z^+} = I_x \tag{4}$$

$$I_{z^-} = -I_x \tag{5}$$

Resistance at X is given by

$$R_x = \frac{1}{2g_m} = \frac{1}{\sqrt{8\beta_n I_b}} \tag{6}$$

Where $\beta_n = \mu_n C_{ox} \frac{W}{L}$ is the physical parameter of the MOS transistor.

III. CMOS IMPLEMENTATION OF CCCII

Fig. 3, 4, and 5 respectively show the schematics of conventional CMOS implementation of positive, negative and dual output current controlled conveyor (CCCII+, CCCII-, DOCCII). We know that MOS-transistors in particular are more suitable for processing currents rather than voltages, because both in common-source and common-gate amplifier configurations the output signal is a current, while common-drain amplifier configuration are almost useless at low supply voltages because of the bulk-effect present in typical CMOS-processes. Moreover, MOS current-mirrors are more accurate and less sensitive to process variation than bipolar current-mirrors because with the latter the base currents limit the accuracy. So, MOS-transistor circuits should be simplified by using current signals in preference to voltage signals. When the signal is conveyed as a current, the voltages in MOS-transistor circuits are proportional to the square root of the signal, if saturation region operation is assumed for the devices [5,7]. Therefore, a compression of voltage signal swing and a reduction of supply voltage is possible. Also, with very high values for the drain currents of the MOS, their maximum usable frequency will be reached sooner.

The circuit in Fig. 3 consists of one mixed trans-linear loop (transistors M1 to M4) as input cell. Two current mirrors (transistors M5, M6 and M7, M9) allow the mixed loop to be dc biased by the current I_b , the input cell present a high input impedance input port (Y) and a low impedance output port(X). This cell act as a voltage follower. The output Z that copies the current flowing through port X is realized in the conventional manner using two complementary mirror [4].

As shown in Fig. 4, current mirrors built up of M11,M12 & M15,M17 and M14,M16 & M10,M13 are cross coupling to generate negative current at Z. While in Fig. 5 generates both types of the output.

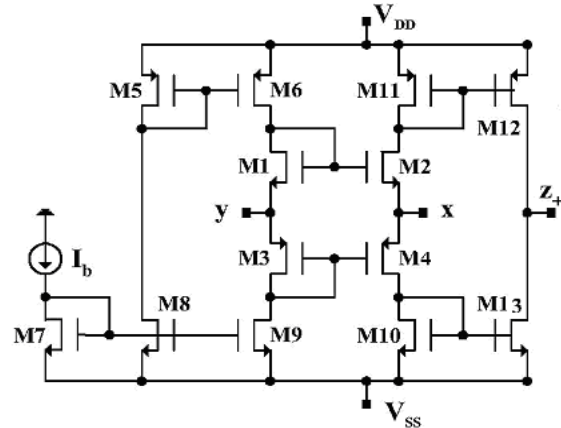

Fig.3 CMOS based circuit of CCCII+

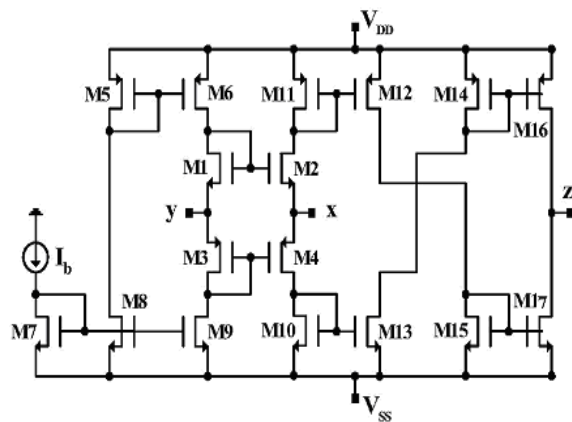

Fig.4 CMOS based circuit of CCCII-

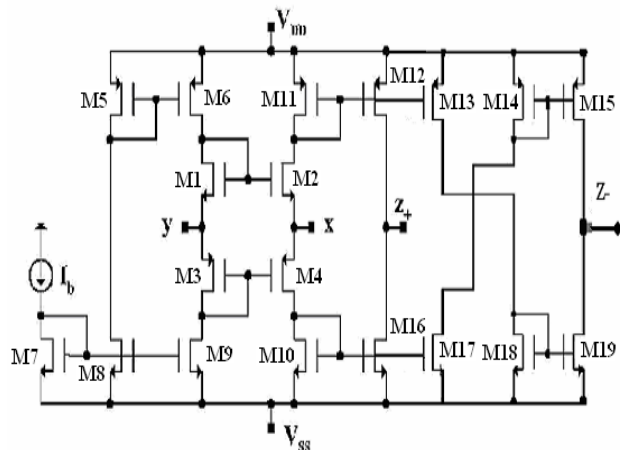

Fig.5 CMOS based circuit of DOCCII

IV. ANALYSIS OF CCCII

Fig. 6, 7, and 8 show the transient and AC analysis of CCCII+, CCCII- and DOCCCII respectively. AC analysis shows the range of frequency of operation and it indicates that current relationship is accurate up to 1GHz for all three CCCII circuits.

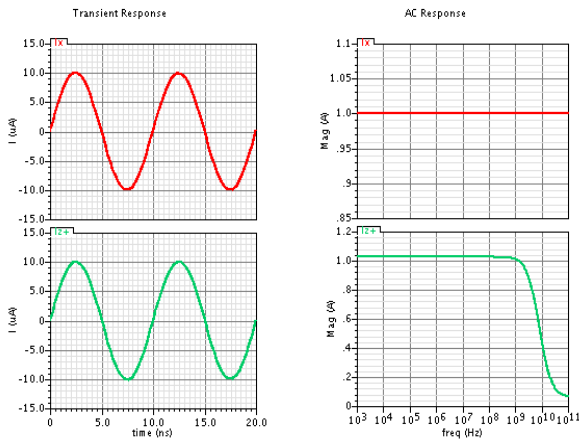

Fig.6 Transient and AC analysis of CCCII+

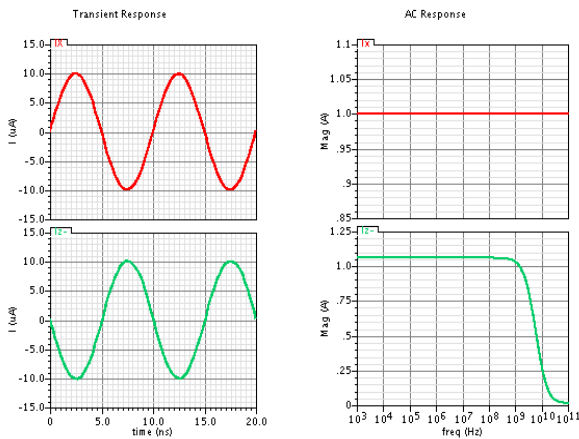

Fig.7: Transient and AC analysis of CCCII-

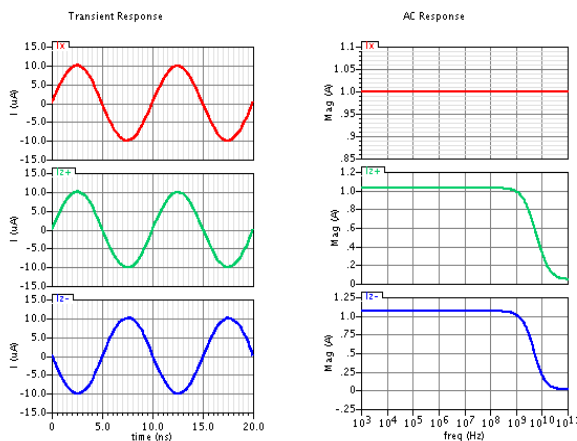

Fig.8: Transient and AC analysis of DOCCCII

Transient analysis has been carried out with 100 MHz frequency sinusoidal input undistorted output. At frequencies higher than 100 MHz we may find phase shift in the output, so its actual range of frequency is around 100MHz.

DC analysis has also been done to find the linearity between input and output ports. So in this way all three CCCII+, CCCII-, DOCCCII verified the current relationship equation i.e. $I_z=+I_x$, $I_z=-I_x$ and $I_z=\pm I_x$ respectively.

V. APPLICATION AS A UNIVERSAL FILTER

CCCII are widely used as basic active building blocks to realize various current-mode active filters. The universal filter is among the most popular analog filters as it can provide several standard functions like low pass, high pass, band pass, band reject and all pass.

In this section, a current mode universal filter has been implemented with single input and three different outputs for low, high and band pass filters. Implementation of Universal filter is shown in Fig.9 using only two DOCCCII and two capacitors, as the dual-output current conveyors is useful in the derivation of current-mode single input and three output filters using a reduced number of active components [8,9,10]. Previously, many realizations of current mode biquadratic filters using CCCII have been reported [10-17].

The analysis i.e. transfer function of the Universal filter can be summarized as follows,

$$\frac{I_{HP}}{I_{in}} = \frac{(-s^2)}{(s^2 + s/R_{x1}C_1 + 1/R_{x1}R_{x2}C_1C_2)} \quad (7)$$

$$\frac{I_{LP}}{I_{in}} = \frac{(-1/R_{x1}R_{x2}C_1C_2)}{(s^2 + s/R_{x1}C_1 + 1/R_{x1}R_{x2}C_1C_2)} \quad (8)$$

$$\frac{I_{BP}}{I_{in}} = \frac{(s/R_{x1}C_1)}{(s^2 + s/R_{x1}C_1 + 1/R_{x1}R_{x2}C_1C_2)} \quad (9)$$

Moreover, the band pass i.e. notch filter response can be obtained by connecting I_{HP} and I_{LP} together as follows.

$$\frac{I_{BR}}{I_{in}} = \frac{-(s^2 + 1/R_{x1}R_{x2}C_1C_2)}{(s^2 + s/R_{x1}C_1 + 1/R_{x1}R_{x2}C_1C_2)} \quad (10)$$

And similarly all pass filter transfer function can be implemented by connecting I_{HP} , I_{LP} and I_{BP} together or I_{BR} and I_{BP} together as below.

$$\frac{I_{AP}}{I_{in}} = \frac{-(s^2 - s/R_{x1}C_1 + 1/R_{x1}R_{x2}C_1C_2)}{(s^2 + s/R_{x1}C_1 + 1/R_{x1}R_{x2}C_1C_2)} \quad (11)$$

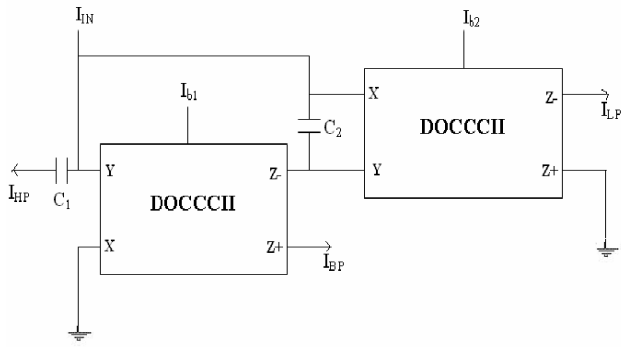

Fig.9 Current Mode Universal Filter using two DOCCII

The natural frequency ω_0 , the bandwidth $\frac{\omega_0}{Q}$ and the Quality factor are given as,

$$\omega_0 = \left(\frac{1}{R_{x1}R_{x2}C_1C_2} \right)^{1/2} \quad (12)$$

$$\omega_0/Q = 1/R_{x1}C_1 \quad (13)$$

$$Q = \left(R_{x1}C_1/R_{x2}C_2 \right)^{1/2} \quad (14)$$

Equations above clearly indicates that $\frac{\omega_0}{Q}$ and ω_0 can be adjusted by the bias currents of I_{b1} and I_{b2} of the respective DOCCII. Transmission of Universal filter is given by

$$T(s) = \frac{(a_2s^2 + a_1s + a_0)}{s^2 + \frac{\omega_0}{Q}s + \omega_0^2} \quad (15)$$

and in our implementation a_2 , a_1 and a_0 are 1, $1/R_{x1}C_1$ and ω_0^2 respectively. The following values of capacitors and bias currents have been used for the implementation of Universal filter.

$$C_1 = C_2 = 250\text{fF}$$

$$I_{b1} = I_{b2} = 2\mu\text{A}$$

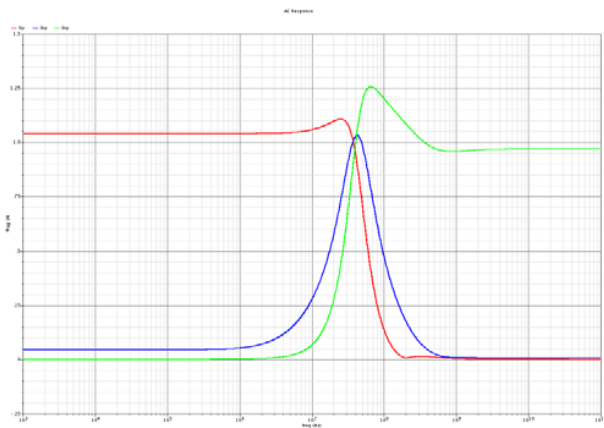

Fig.10 Frequency Response of Low, High and Band Pass Filters

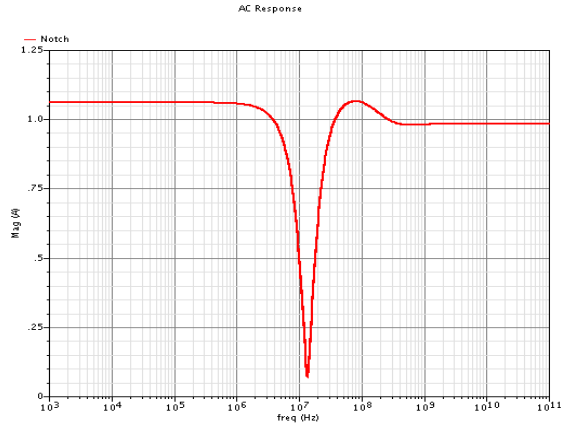

Fig.11 Frequency Response of Notch Filter

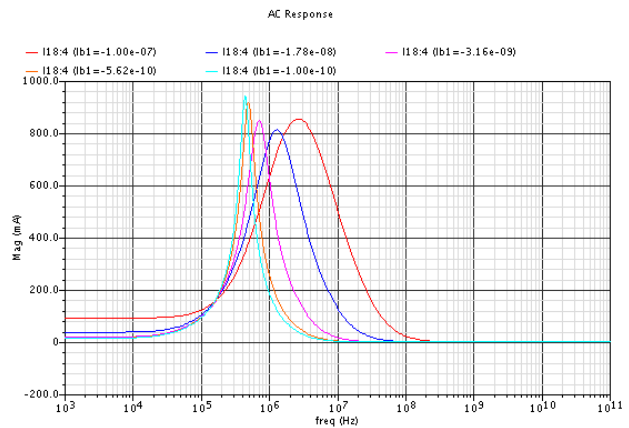

Fig.12: Band Pass Filter response with variation in bias currents

Fig10 and Fig11 shows frequency responses for low, high & band pass filter and notch filter respectively. Fig12 shows the tunability in band pass filter as its response in changing with the variation in bias currents. After simulation with Virtuoso (Cadence) using 65nm CMOS parameters, we get the following results.

TABLE I
RESULTS ARE SHOWING GOOD RESPONSE AND RESEMBLES WITH THE EXPECTED VALUES

	High Pass	Low Pass	Band Pass
Band-width	31.9MHz	49.46 MHz	45.27 MHz
Peak Freq.	65.46 MHz	25.12 MHz	42.85 MHz

We also find the Quality factor 0.95. All results are showing good response and resembles with the expected values.

VI. CONCLUSION

We presented a CMOS implementation of CCCII+, CCCII-, DOCCII circuit in 65nm CMOS technology. The design, based on a $\pm 0.5\text{V}$ DC supply and developed using Virtuoso Cadence tool, achieves good linearity, low power dissipation and high bandwidth in the device. As an application we have

simulated a current mode second order universal filter (Low Pass, High Pass, Band Pass, All Pass and Notch filters) using two DOCCCII and two capacitor showing a good agreement with expected results.

REFERENCES

- [1] C. Toumazou., F. J. Lidgey, and D. G. Haigh, *Analogue IC design: the current-mode approach*, London: Peter Peregrinus, 1990.
- [2] D. R. Bhaskar, V. K. Sharma, M. Monis, and S. M. I. Rizvi, "New current-mode universal biquad filter," *Microelectronics Journal*, vol. 30, pp. 837-839, 1999.
- [3] Alain Fabre, Senior Member, IEEE, Omar Saaid, Francis Wiest, Member, IEEE, and Christophe Boucheron" High Frequency Applications Based on A new Current Controlled Conveyor" *IEEE Transactions On Circuits And Systems-I: Fundamental Theory And Applications*, Vol. 43, No. 2, February 1996.
- [4] Sedra, K. C. Smith, "A second generation current conveyor and its application", *IEE Trans. Circuit Theory*, 1970, pp. 132-134.
- [5] K. Smith and A. Sedra, "Microelectronic circuits," pp. 368-569, 1999.
- [6] A. Fabre, O. Saaid, F. Wiest, and C. Boucheron, "Current controllable bandpass filter based on translinear conveyors," *Electron. Lett.*, vol. 31, pp.1727-1728, 1995.
- [7] Giuseppe Ferri, Nicola C. Guerrini 'Low voltage Low power CMOS Current Conveyors' Kluwar Academic Publications, pp. 2-12.
- [8] K. Ikeda and Y. Tomita, "Realization of current-mode biquadratic filter using CCII's with current followers," *Electronics and Communications in Japan*, part 2, vol. 77, pp. 99-107, 1994.
- [9] A. M. Soliman, "New current mode filters using current conveyors,"*International Journal of Electronics and Communication (AEU)*, vol. 51, pp. 275-278, 1997.
- [10] N. A. Shah, M. F. Rather and S. Z. Iqbal "SITO electronically tunable high output impedance current mode Universal filter" April 2006 *Springer Science – 2006*.
- [11] Winai Jaikla and Montree Siripruchyanun, "Current Controlled Current Conveyor-Based Current mode Universal Filter", *ISCIT'09 Proceedings of the 9th international conference on Communications and information technologies*, pp 893-896, IEEE Press Piscataway, NJ, USA 2009.
- [12] M.T Abuelma'atti and N.A. Tasadduq, "Universal current-controlled current-mode filter using the multiple-output translinear current conveyor," *Frequenz*, vol. 52, pp. 252-254, 1998.
- [13] Neeta Pandey, Sajal K. Paul and S.B.Jain, "A new electronically tunable current mode universal filter using MO-CCCII", *Analog Integrated Circuits for Signal Processing*, 58, 171-178, 2009.
- [14] E. Yuce, S. Minaei and O. Cicekoglu, "Universal current-mode active-C filter employing minimum number of passive elements," *Analog integrated circuits and signal Processing*, vol. 42, pp. 169-171, 2006.
- [15] S. Minaei and S. Türköz, "Current-mode electronically tunable universal filter using only plus-type current controlled conveyors and grounded capacitors," *ETRI Journal*, vol.26, pp. 292-296, 2004.
- [16] W. Tangsrirat and D. Prasertsom, "Electronically tunable low component count current-mode biquadratic filter using dual-output current followers," *Electrical Engineering*, 2006.
- [17] S. Minaei, O. Çiçekoglu, H. Kuntman, S. Türköz, "High output impedance current-mode lowpass, bandpass and highpass filters using current controlled conveyors," *International Journal of Electronics*, vol. 88, pp. 915-922, 2001.