

Design and Development of Ferroelectric Material for Microstrip Patch Array Antenna

F.H.Wee and F. Malek

Abstract—This paper presents the utilizing of ferroelectric material on antenna application. There are two different ferroelectric had been used on the proposed antennas which include of Barium Strontium Titanate (BST) and Bismuth Titanate (BiT), suitable for Access Points operating in the WLAN IEEE 802.11 b/g and WiMAX IEEE 802.16 within the range of 2.3 GHz to 2.5 GHz application. BST, which had been tested to own a dielectric constant of $\epsilon_r = 15$ while BiT has a dielectric constant that higher than BST which is $\epsilon_r = 21$ and both materials are in rectangular shaped. The influence of various parameters on antenna characteristics were investigated extensively using commercial electromagnetic simulations software by Communication Simulation Technology (CST). From theoretical analysis and simulation results, it was demonstrated that ferroelectric material used have not only improved the directive emission but also enhanced the radiation efficiency.

Keywords—Ferroelectric material, WLAN, WiMAX, dielectric constant

I. INTRODUCTION

THE use of material with high dielectric constant as in antenna radiation element have received extensive research attention due to their favorable characteristics, which includes (1) high radiation efficiency; (2) low temperature coefficient, and (3) suitable scale in antenna design [1], [2]. Combined with the small amount of conductor losses that complements the designs, structures of this breed have allowed the achievement of high radiation efficiency [3], [4]. Ferroelectric material like Barium Strontium Titanate and Bismuth Titanate, also known as a solid solution *perovskite* with a field-dependent permittivity, is one of the more popularly investigated in recent years [5], [6]. Ferroelectric materials with a perovskite structure are very significant electronic materials. They are most often used in the production of capacitors as it has a high temperature coefficient of resonant frequency, large dielectric constant and high dielectric losses [8].

Barium Strontium Titanate (BST) composed of $\text{Ba}_{0.5}\text{Sr}_{0.5}\text{TiO}_3$ has a potential to overcome all the limitations of MEMS, ferrite and MMIC phase shifters as it has an electric tunable dielectric constant [7]- [10]. Combining the low-loss properties of ferroelectric material at microwave frequencies, the distributed transmission line philosophy of the MEMS phase shifter provides a wide bandwidth coverage and ease of design.

F.H.Wee is with the School of Computer and Communication Engineering, Universiti Malaysia Perlis, Perlis, Malaysia. (e-mail: weefwenhoon@gmail.com).

F.Malek, was with, Universiti Malaysia Perlis. He is now with the School of Electrical Systems Engineering, Universiti Malaysia Perlis, Perlis, Malaysia (e-mail: mfareq@unimap.edu.my).

Other interesting aspects of this material are its low dielectric loss, low leakage current, and the composition-dependent Curie temperature [10].

Bismut Titanate (BiT) with the composition of $\text{Bi}_4\text{Ti}_3\text{O}_{12}$, since its discovery in 1949 by Aurivillius [1], has been extensively studied for its ferroelectric and other excellent properties. BiT is a candidate material for high temperature piezoelectric applications, memory storage, and optical displays because of its high Curie temperature and electro-optical properties [2]. Ferroelectric BiT ceramic is potential candidates for device applications due to their high dielectric constant and high breakdown strength [3], [4]. The properties of BiT have been reported in a number of papers, cited among others in [5]– [7].

This work was implemented to investigate on the best custom size and design of a rectangular array antenna for WLAN Access Point using ferroelectric materials. Ferroelectric material made from BST and BiT were incorporated into the normal rectangular antenna structure as its loading element, utilizing assembly methods and techniques referred in [8], [9]. Both antenna models were simulated and optimized using the CST software, while the physical parameters measured thoroughly. A high dielectric loading through the use of BiT was expected to reduce the overall rectangular array antenna size. In order to obtain a good fundamental antenna design, the initial studies were carried out theoretically, both by calculation, simulation and parametric study.

II. BST AND BIT FABRICATION

BST is commonly given in powder form and such composition can help to store and use the material for any experiment and moulding processes. Heat applied during fabrication of BST into various shapes would increase the dielectric constant from a few hundreds to thousands, due to structural changes from tetragonal to cubic *perovskite*.

BiT ceramics were conventionally prepared by a solid-state reaction process, where an oxide mixture of Bi_2O_3 and TiO_2 was ball milled, calcined at an intermediate temperature and finally sintered at a high temperature [8], [9]. The conventional method requires a high calcination temperature, usually leading to inevitable particle coarsening and aggregation of $\text{Bi}_4\text{Ti}_3\text{O}_{12}$ powders. The presence of hard particle agglomerates will also results in a poor microstructure and properties of BiT ceramics [9]. Many efforts have been made to avoid this problem by lowering the calcination temperature. The methods reported in literature for preparing BiT ceramics include co-precipitation, sol-gel, hydrothermal, and molten salt synthesis.

The ferroelectric material antenna, which may be designed using various geometries (such as rectangles, cylinders, rings, hemispheres, etc) was designed to be geometrically small and lightweight [1], [5]. The rectangular shaped was chosen as the subject of examination, as it allowed neat arrangement on antenna substrate compared with other geometries, and this is important for reducing mutual coupling occur [8]. The resonant frequency of array antenna is primarily determined by its size, shape, material relative permittivity (ϵ_r), its mode of operation, and coupling to other structures around it.

The BiT and BST synthesis techniques were mentioned in a lot of papers. All techniques and methods can produce ceramics with device-quality characteristics. Numerous different thin film deposition techniques exist, and these techniques are usually divided in two main groups, Physical Vapor Deposition (PVD) and Chemical Vapor Deposition (CVD) [3].

III. ANTENNA DESIGN

A dielectric structure which is not entirely enclosed by a conductive boundary can radiate as an antenna. This was the first part of this investigation, which was carried out to determine the effectiveness of BST and BiT as a radiating element itself.

In this design, rectangular ferroelectric material array antenna each of same height h , width w and thickness, t respectively are arranged in a planar configuration over a copper ground plane (GP) and are symmetrically packed together in the most compact fashion as shown in Fig. 1 and Fig. 2 respectively. The array is excited centrally by a metallic line feed having its length L above the GP. The central metallic plate is surrounded by dielectric ceramic in rectangular form so that its boundary just touches each DRA element and helps in exciting them.

The dielectric ceramic uses high dielectric constant bismuth titanate, which has a dielectric constant of 21 do have the ability to produce smaller antenna compare to barium strontium titanate that is of 15 in dielectric constant as shown in Fig. 1, Fig. 2 and Table I. The metallic feeding line uses copper, which is a conducting material, in order to function as a feeding channel. The width, W , of feeding line was calculated to be 4.6 mm. This width of the transmission line will provide an input impedance of 50 ohm. In addition, the dielectric ceramic's dimensions will greatly affect the resonant frequency and the Q-value. The BST array antenna is designed using RT/Duroid 5880 dielectric-constant substrate material from Rogers Corp. (www.rogerscorp.com) with a dielectric constant of only 2.2.

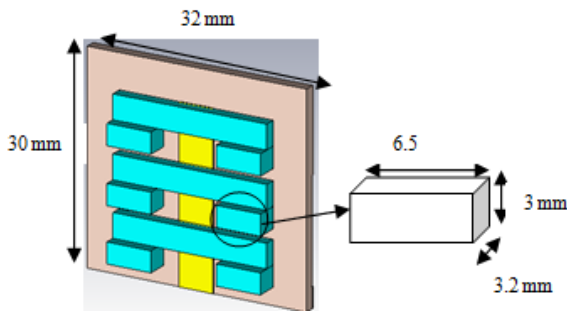

(a)



(b)

Fig. 1 BST ferroelectric material microstrip patch array antenna (a) Simulated and its dimensions, (b) Fabricated.

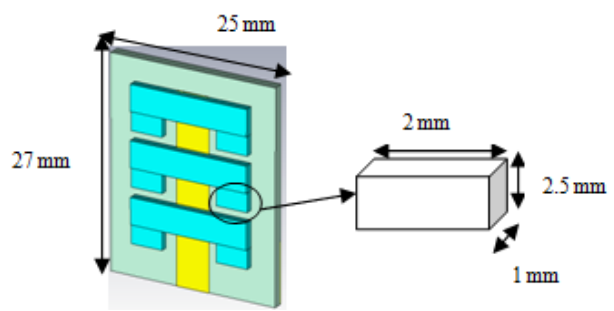

(a)

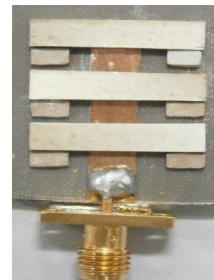

(b)

Fig. 2 BiT ferroelectric material microstrip patch antenna (a) Simulated and its dimensions, (b) Fabricated.

TABLE I
DIMENSIONS OF BST AND BIT ARRAY ANTENNA

Configuration	Four element array antenna	
	BST	BIT
Dimension of substrate [mm]	H = 30	H = 27
	W = 32	W = 25
	T = 1.575	T = 1.575

*Height = h; Width = w; Thickness = t

IV. RESULTS AND DISCUSSION

The simulated and measured S_{11} for the BST and BiT array antennas are shown in Fig. 3. The results indicated that the resonant frequency at range about 2.30 GHz to 2.50 GHz.

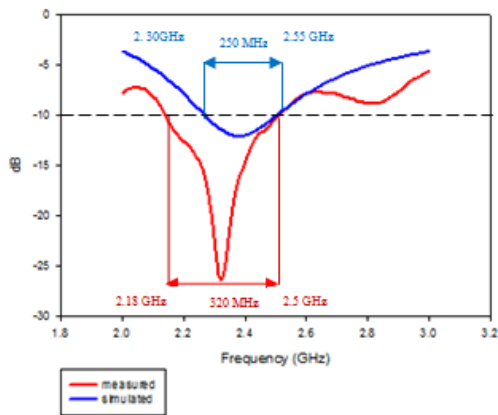
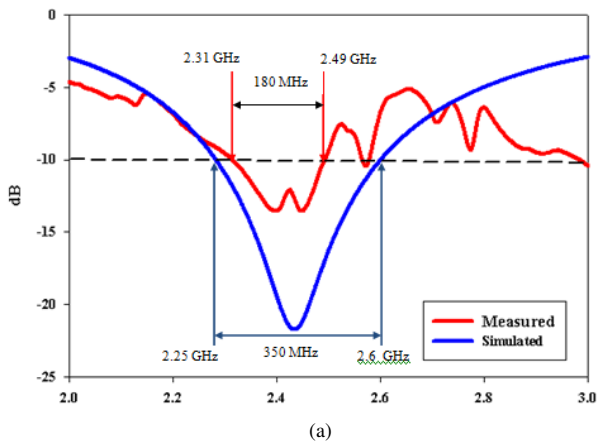
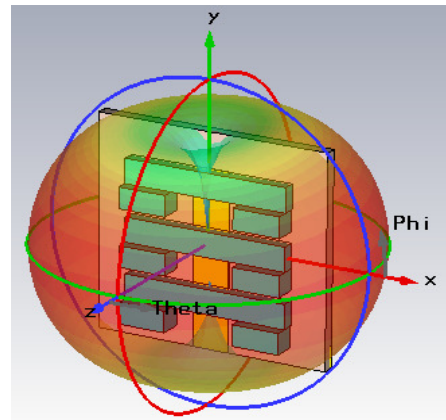
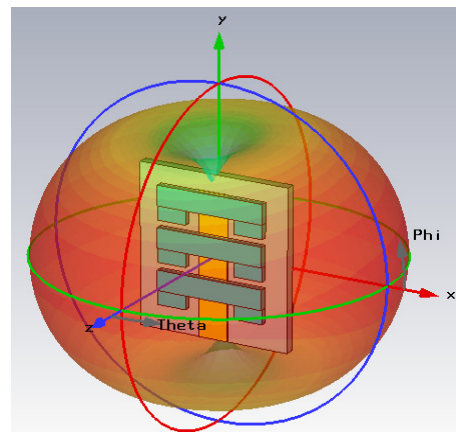

Fig. 3 Simulated and Measured S_{11} (a) BST loaded array antenna (b) BIT loaded array antenna

It is clearly shown that both rectangular BST and BiT array antenna excited a good bandwidth, therefore proving it to be suitable for WLAN and WiMAX applications.



(a)



(b)

Fig. 4 Simulated radiation pattern of (a) BST and (b) BiT

Fig. 4 displays the far-field radiation pattern in y-z and x-z planes, respectively. Each of the radiation pattern was normalized by the maxima of both y-z and x-z planes. Radiation performance of the BST array antenna was examined on two principal planes, E(y-z) and H(x-z) as well for the BiT array antenna. In a plane of interest, the radiation patterns for E and H plane components were found to be relatively stable and symmetrical. This was owing to a symmetrical arrangement which produced a good radiation performance with omni-directional.

Referring to Table II, the gain of BiT array antenna seem to be higher compare to the BST array antenna. It indicate that antenna with material of higher dielectric constant value does stored much energy which have the capability to produce high power signal transfer thus perform better with strong radiation signal.

TABLE II
GAIN OF BST AND BiT ARRAY ANTENNAS

Parameters	BST array antenna		
	2.3 GHz	2.4 GHz	2.5 GHz
Gain (dB)	6.117	6.119	6.123

Parameters	BiT array antenna		
	2.3 GHz	2.4 GHz	2.5 GHz
Gain (dB)	6.225	6.275	6.311

V. CONCLUSION

In this paper, the application of rectangular Barium Strontium Titanate (BST) and Bismuth Titanate (BiT) materials as ferroelectric array antenna was proposed and successfully carried out. The antenna exhibited acceptable bandwidths, reflections and radiation characteristics (high gain antenna) for WLAN and WiMAX application. The accomplishment of acceptable bandwidth is definitely an important consideration for antenna design in WLAN and WiMAX frequencies band. By taking into account all the details of each component including dimensions and dielectric constant value, the antennas did perform up to expectation in the ISM band. The performance of these antennas can be improved with one uses BiT which has high dielectric constant and low conductor loss. In this case, the size of the array antenna with BiT is rather smaller than the BST array antenna one, and the antenna gain of BiT loaded is higher than BST loaded antenna. As future work, Barium Strontium Titanate (BST) and Bismuth Titanate (BiT) can be investigated for others types of antenna in order determine the level of performance improvement in term of bandwidth particularly and optimized antenna polarization.

REFERENCES

- [1] J. R. Sohn, K. Y. Kim, and H.S. Tae, "Comparative Study on Various Artificial Magnetic Conductor for Low Profile Antenna," Progress In Electromagnetics Research, PIER 61, 27–37, 2006.
- [2] Hongyan Miao & Yaohui Zhou & Guoqiang Tan & Min Dong , " Microstructure and Dielectric Properties of Ferroelectric Barium Strontium Titanate Ceramics prepared by Hydrothermal Method," J Electroceram DOI 10.1007/s10832-007-9244-x Springer Science Business Media, LLC 2007.
- [3] Li B., Wu B., and Liang C.H., "Study on High Gain Circular Waveguide Array Antenna with Metamaterial Structure," Progress In Electromagnetic Research, PIER 60, 207–219, 2006.
- [4] Shok Theng Low, Zhipeng Wu, "Microstrip Coupled Rectangular Dielectric Resonator Antennas on Different Substrates Antenna Technology: Small and Smart Antennas Metamaterials and Applications" IWAT '07. International Workshop Page(s):341 – 344,on 21-23 March 2007.
- [5] K. Pliakostathis, D. Mirshekar-Syahkal, "A novel enclosed cylindrical dielectric resonator antenna" Antennas and Propagation Society International Symposim, IEEE Vil.4, 16-21 June 2002, Page(s): 474-477.
- [6] Tsugawa et al:"High Gain Antenna Loaded by a Dielectric," National Convention of IEICE, Japan, March 1987, Page(s): 120.
- [7] Heng-Ming Deng; Tsung-Wen Chen; Hsiao-Hsun Kan; "A CPW-fed rectangular dielectric resonator antenna" Microwave Conference, 2001. APMC 2001. 2001 Asia-Pacific vol.2, 3-6 Dec. 2001 page(s): 954 – 957.
- [8] Capozzoli and G. D'Elia, "Global Optimization and Antennas Synthesis and Diagnosis, Part Two: Applications to Advanced Reflector Antennas Synthesis and Diagnosis Techniques," Progress In Electromagnetics Research, PIER 56, 233–261, 2006.
- [9] Mongia R. K. and Bhartia P., "Dielectric Resonator Antennas - A Review and General Relations for Resonant Frequency and Bandwidth",

Int. Journal of Microwave and Millimetre Wave Computer-Aided Engineering, Vol. 4, No. 3, page(s): 230-247, 1994.

- [10] N.V Larsen, O. Breinbjerg, "Analysis of Circularly Polarized Hemispheroidal Dielectric Resonator Antenna Phased Arrays Using the Method of Auxiliary Sources", IEEE Transactions on Antenna and Propagation, Vol 55, Issue 8, Aug.2007 Page(s)2163-2173.