

# Nickel on Inner Surface and Stainless Steel on Outer Surface for Functionally Graded Cylindrical Shell

A.R.Tahmasebi Birgani<sup>1,\*</sup>, M.Hosseinjani Zamenjani<sup>2</sup>, M.R.Isvandzibaei<sup>3</sup>

**Abstract**—Study is on the vibration of thin cylindrical shells made of a functionally gradient material (FGM) composed of stainless steel and nickel is presented. The effects of the FGM configuration are studied by studying the frequencies of FG cylindrical shells. In this case FG cylindrical shell has Nickel on its inner surface and stainless steel on its outer surface. The study is carried out based on third order shear deformation shell theory. The objective is to study the natural frequencies, the influence of constituent volume fractions and the effects of configurations of the constituent materials on the frequencies. The properties are graded in the thickness direction according to the volume fraction power-law distribution. Results are presented on the frequency characteristics, the influence of the constituent various volume fractions on the frequencies.

**Keywords**—Nickel, Stainless Steel, Cylindrical shell.

## I. INTRODUCTION

STAINLESS STEEL are often used as load bearing structures for aircrafts, ships and buildings. Understanding of vibration behavior of cylindrical shells is an important aspect for the successful applications of cylindrical shells. Researches on free vibrations of cylindrical shells have been carried out extensively [1-5]. Recently, the present authors presented studies on the influence of boundary conditions on the frequencies of a multi-layered cylindrical shell [6]. In all the above works, different thin shell theories based on Love-

hypothesis were used. Vibration of cylindrical shells with ring support is considered by Loy and Lam [7]. The concept of functionally graded materials (FGMs) was first introduced in 1984 by a group of materials scientists in Japan [8-9] as a means of preparing thermal barrier materials. Since then, FGMs have attracted much interest as heat-shielding materials. FGMs are made by combining different materials using power metallurgy methods [10]. Vibration study of FG cylindrical shell structures is important. This cylindrical shell considered are composed of stainless steel and nickel where the volume fractions follow a power-law distribution.

## II. FUNCTIONALLY GRADED MATERIALS

For the cylindrical shell made of FGM the material properties such as the modulus of elasticity  $E$ , Poisson ratio  $\nu$  and the mass density  $\rho$  are assumed to be functions of the volume fraction of the constituent materials when the coordinate axis across the shell thickness is denoted by  $z$  and measured from the shell's middle plane. The functional relationships between  $E, \nu$  and  $\rho$  with  $z$  for a stainless steel and nickel FGM shell are assumed as:

$$E = (E_1 - E_2) \left( \frac{2Z + h}{2h} \right)^N + E_2 \quad (1)$$

$$\nu = (\nu_1 - \nu_2) \left( \frac{2Z + h}{2h} \right)^N + \nu_2 \quad (2)$$

$$\rho = (\rho_1 - \rho_2) \left( \frac{2Z + h}{2h} \right)^N + \rho_2 \quad (3)$$

The third- order theory of Reddy used in the present study is based on the following displacement field:

$$\begin{cases} U_1 = u_1(\alpha_1, \alpha_2) + \alpha_3 \phi_1(\alpha_1, \alpha_2) + \alpha_3^2 \psi_1(\alpha_1, \alpha_2) + \alpha_3^3 \beta_1(\alpha_1, \alpha_2) \\ U_2 = u_2(\alpha_1, \alpha_2) + \alpha_3 \phi_2(\alpha_1, \alpha_2) + \alpha_3^2 \psi_2(\alpha_1, \alpha_2) + \alpha_3^3 \beta_2(\alpha_1, \alpha_2) \\ U_3 = u_3(\alpha_1, \alpha_2) \end{cases} \quad (4)$$

These equations can be reduced by satisfying the stress-free conditions on the top and bottom faces of the laminates, which are equivalent to  $\epsilon_{13} = \epsilon_{23} = 0$  at  $Z = \pm \frac{h}{2}$ . Thus

<sup>1,\*</sup> A.R.Tahmasebi Birgani, Islamic Azad University, Shoushtar Branch, Department of Engineering, Shoushtar, Iran. Corresponding author, *E-mail address*: tahmasbi\_22@yahoo.com, Tell: +98 9163140918

<sup>2</sup> M.Hosseinjani Zamenjani, Islamic Azad University, Shoushtar Branch, Department of Engineering, Shoushtar, Iran.

<sup>3</sup> M.R.Isvandzibaei, Islamic Azad University, Andimeshk Branch, Andimeshk, Iran.

$$\begin{cases} U_1 = u_1(\alpha_1, \alpha_2) + \alpha_3 \phi_1(\alpha_1, \alpha_2) - C_1 \alpha_3^3 \left( -\frac{u_1}{R_1} + \phi_1 + \frac{\partial u_3}{A_1 \partial \alpha_1} \right) \\ U_2 = u_2(\alpha_1, \alpha_2) + \alpha_3 \phi_2(\alpha_1, \alpha_2) - C_1 \alpha_3^3 \left( -\frac{u_2}{R_2} + \phi_2 + \frac{\partial u_3}{A_2 \partial \alpha_2} \right) \\ U_3 = u_3(\alpha_1, \alpha_2) \end{cases} \quad (5)$$

III. FORMULATION

Consider a cylindrical shell is shown in Fig.1.  $R$  is the radius,  $L$  is the length and  $h$  is the thickness. The reference surface is chosen to be the middle surface of the cylindrical shell where an orthogonal coordinate system  $x, \theta, z$  is fixed. The deformations of the shell with reference to this coordinate system are denoted by  $U_1, U_2$  and  $U_3$  in the  $x, \theta$  and  $z$  directions, respectively.

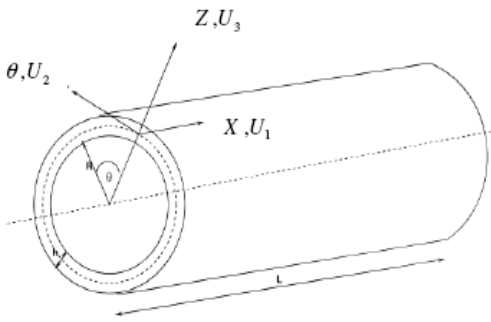

Fig. 1 Geometry of a cylindrical shell

For a thin cylindrical shell, plane stress condition can be assumed. The constitutive relation for a thin cylindrical shell is consequently given by the two-dimensional Hook's law as

$$\{\sigma\} = [Q] \{\varepsilon\} \quad (6)$$

where,  $\{\sigma\}$  is the stress vector,  $\{\varepsilon\}$  is the strain vector and  $[Q]$  is the reduced stiffness matrix. The stress vector for plane stress condition is

$$\{\sigma\}^T = \{\sigma_{11} \quad \sigma_{22} \quad \sigma_{12} \quad \sigma_{13} \quad \sigma_{23}\} \quad (7)$$

where  $\sigma_{11}$  is the stress in  $x$  direction,  $\sigma_{22}$  the stress in the  $\theta$  direction and  $\sigma_{12}$  is the shear stress on the  $x\theta$  plane and  $\sigma_{13}$  is the shear stress on the  $xz$  plane and  $\sigma_{23}$  is the shear stress on the  $\theta z$  plane. The strain vector is defined as

$$\{\varepsilon\}^T = \{\varepsilon_{11} \quad \varepsilon_{22} \quad \varepsilon_{12} \quad \varepsilon_{13} \quad \varepsilon_{23}\} \quad (8)$$

where  $\varepsilon_{11}$  is the strain in  $x$  direction,  $\varepsilon_{22}$  the strain in the  $\theta$  direction and  $\varepsilon_{12}$  is the shear strain on the  $x\theta$  plane and  $\varepsilon_{13}$  is the shear strain on the  $xz$  plane and  $\varepsilon_{23}$  is the shear

strain on the  $\theta z$  plane. The reduced stiffness  $[Q]$  matrix is given as

$$[Q] = \begin{bmatrix} Q_{11} & Q_{12} & 0 & 0 & 0 \\ Q_{12} & Q_{22} & 0 & 0 & 0 \\ 0 & 0 & Q_{44} & 0 & 0 \\ 0 & 0 & 0 & Q_{55} & 0 \\ 0 & 0 & 0 & 0 & Q_{66} \end{bmatrix} \quad (9)$$

For an isotropic cylindrical shell the reduced stiffness  $Q_{ij}$  ( $i, j=1, 2$  and  $6$ ) are defined as

$$Q_{11} = Q_{22} = \frac{E}{1 - \nu^2} \quad (10)$$

$$Q_{12} = \frac{\nu E}{1 - \nu^2} \quad (11)$$

$$Q_{44} = Q_{55} = Q_{66} = \frac{E}{2(1 + \nu)} \quad (12)$$

where  $E$  is the Young's modulus and  $\nu$  is Poisson's ratio. For a thin cylindrical shell the force and moment results are defined as

$$\begin{Bmatrix} N_{11} \\ N_{22} \\ N_{12} \end{Bmatrix} = \int_{-\frac{h}{2}}^{\frac{h}{2}} \begin{Bmatrix} \sigma_{11} \\ \sigma_{22} \\ \sigma_{12} \end{Bmatrix} d\alpha_3, \quad \begin{Bmatrix} M_{11} \\ M_{22} \\ M_{12} \end{Bmatrix} = \int_{-\frac{h}{2}}^{\frac{h}{2}} \begin{Bmatrix} \sigma_{11} \\ \sigma_{22} \\ \sigma_{12} \end{Bmatrix} \alpha_3^2 d\alpha_3 \quad (13)$$

$$\begin{Bmatrix} P_{11} \\ P_{22} \\ P_{12} \end{Bmatrix} = \int_{-\frac{h}{2}}^{\frac{h}{2}} \begin{Bmatrix} \sigma_{11} \\ \sigma_{22} \\ \sigma_{12} \end{Bmatrix} \alpha_3^3 d\alpha_3, \quad \begin{Bmatrix} P_{13} \\ P_{23} \end{Bmatrix} = \int_{-\frac{h}{2}}^{\frac{h}{2}} \begin{Bmatrix} \sigma_{13} \\ \sigma_{23} \end{Bmatrix} \alpha_3^3 d\alpha_3 \quad (14)$$

$$\begin{Bmatrix} Q_3 \\ Q_{23} \end{Bmatrix} = \int_{-\frac{h}{2}}^{\frac{h}{2}} \begin{Bmatrix} \sigma_{13} \\ \sigma_{23} \end{Bmatrix} d\alpha_3, \quad \begin{Bmatrix} R_{13} \\ R_{23} \end{Bmatrix} = \int_{-\frac{h}{2}}^{\frac{h}{2}} \begin{Bmatrix} \sigma_{13} \\ \sigma_{23} \end{Bmatrix} \alpha_3^2 d\alpha_3 \quad (15)$$

The constitutive equation is obtained as

$$\{N\} = [S] \{\varepsilon\} \quad (16)$$

where  $\{N\}$  and  $\{\varepsilon\}$  are, respectively, defined as

$$\{N\}^T = \{N_1 \quad N_2 \quad N_{12} \quad M_1 \quad M_2 \quad M_{12} \quad P_1 \quad P_2 \quad P_3 \quad P_{13} \quad P_{23} \quad Q_3 \quad Q_{23} \quad R_{13} \quad R_{23}\} \quad (17)$$

$$\{\varepsilon\}^T = \{\varepsilon_{11}^0 \quad \varepsilon_{22}^0 \quad \varepsilon_{12}^0 \quad k_{11} \quad k_{22} \quad k_{12} \quad k_{11} \quad k_{22} \quad k_{12} \quad \gamma_{13}^0 \quad \gamma_{23}^0 \quad \gamma_{13}^2 \quad \gamma_{23}^2 \quad \gamma_{13}^3 \quad \gamma_{23}^3\} \quad (18)$$

and  $[S]$  is defined as

$$[S] = \begin{bmatrix} [A] & [B] & [E] \\ [B] & [D] & [F] \\ [E] & [F] & [H] \\ [E'] & [G] & [H'] \\ [A'] & [D'] & [E'] \\ [D'] & [F'] & [G'] \end{bmatrix} \quad (19)$$

where A, B, E, D, F, H and G are the extensional, coupling and bending stiffness matrices and  $Q_{ij}$  are functions of  $z$  for functionally gradient materials. Here  $A_{ij}$  denote the extensional stiffness,  $D_{ij}$  the bending stiffness,  $B_{ij}$  the bending-extensional coupling stiffness and  $E_{ij}, F_{ij}, G_{ij}, H_{ij}$  are the extensional, bending, coupling, and higher-order stiffness. Defining

$$\{A_{ij}, B_{ij}, D_{ij}, E_{ij}, F_{ij}, G_{ij}, H_{ij}\} = \int_{-h/2}^{h/2} Q_{ij} \{1, \alpha_3, \alpha_3^2, \alpha_3^3, \alpha_3^4, \alpha_3^5, \alpha_3^6\} d\alpha_3 \quad (20)$$

The strain energy and kinetic energy of a cylindrical shell can be defined as

$$U = \frac{1}{2} \iiint_V \{\varepsilon\}^T \{\sigma\} dV \quad (21)$$

$$T = \frac{1}{2} \iiint_V \rho \left[ \left( \frac{\partial u_1}{\partial t} \right)^2 + \left( \frac{\partial u_2}{\partial t} \right)^2 + \left( \frac{\partial u_3}{\partial t} \right)^2 + \left( \frac{\partial \phi_1}{\partial t} \right)^2 + \left( \frac{\partial \phi_2}{\partial t} \right)^2 \right] dV \quad (22)$$

where,  $\rho$  is the mass density,  $\{\varepsilon\}$  is the strain vector and  $\{\sigma\}$  is the stress vector. By substituting from Eq. (6), the strain and kinetic energies can be written as

$$U = \frac{1}{2} \int_0^L \int_0^{2\pi} \int_0^t \{\varepsilon\}^T [S] \{\varepsilon\} R d\theta dx \quad (23)$$

$$T = \frac{1}{2} \int_0^L \int_0^{2\pi} \rho R \left[ \left( \frac{\partial u_1}{\partial t} \right)^2 + \left( \frac{\partial u_2}{\partial t} \right)^2 + \left( \frac{\partial u_3}{\partial t} \right)^2 + \left( \frac{\partial \phi_1}{\partial t} \right)^2 + \left( \frac{\partial \phi_2}{\partial t} \right)^2 \right] R d\theta dx \quad (24)$$

The displacement fields for a cylindrical shell can be written as:

$$\begin{aligned} u_1 &= \bar{A} \frac{\partial \phi(x)}{\partial x} \cos(n\theta) \cos(\omega t) \\ u_2 &= \bar{B} \phi(x) \sin(n\theta) \cos(\omega t) \\ u_3 &= \bar{C} \phi(x) \cos(n\theta) \cos(\omega t) \\ \phi_1 &= \bar{D} \frac{\partial \phi(x)}{\partial x} \cos(n\theta) \cos(\omega t) \\ \phi_2 &= \bar{E} \phi(x) \sin(n\theta) \cos(\omega t) \end{aligned} \quad (25)$$

where,  $\bar{A}, \bar{B}, \bar{C}, \bar{D}$  and  $\bar{E}$  are the constants denoting the amplitudes of the vibrations in the  $x, \theta$  and  $z$  directions,  $\phi(x)$  is the axial function that satisfies the geometric

boundary conditions,  $n$  denotes the number of circumferential waves in the mode shape and  $\omega$  is the natural angular frequency of the vibration. The axial function  $\phi(x)$  is chosen as the beam function as:

$$\phi(x) = \alpha_1 \cosh\left(\frac{\lambda_m x}{L}\right) + \alpha_2 \cos\left(\frac{\lambda_m x}{L}\right) - \zeta_m (\alpha_3 \sinh\left(\frac{\lambda_m x}{L}\right) + \alpha_4 \sin\left(\frac{\lambda_m x}{L}\right)) \quad (26)$$

where  $\alpha_i$  ( $i = 1, \dots, 4$ ) are some constants with value 0 or 1 chosen according to the boundary conditions.  $\lambda_m$ , are the roots of some transcendental equations and  $\zeta_m$  are some parameters dependent on  $\lambda_m$ . The energy functional  $\Pi$  defined by the Lagrangian function as

$$\Pi = T_{\max} - U_{\max} \quad (27)$$

With minimizing the energy functional  $\Pi$  with respect to the unknown coefficients as follows,

$$\frac{\partial \Pi}{\partial A} = \frac{\partial \Pi}{\partial B} = \frac{\partial \Pi}{\partial C} = \frac{\partial \Pi}{\partial D} = \frac{\partial \Pi}{\partial E} = 0 \quad (28)$$

$T_{\max}$  and  $U_{\max}$  are the maximum kinetic energy and strain energy, respectively. In Eq. (28), the five governing eigenvalue equations can be obtained. These five governing eigenvalue equation can be expressed in matrix form as

$$\begin{bmatrix} C_{11} & C_{12} & C_{13} & C_{14} & C_{15} \\ C_{21} & C_{22} & C_{23} & C_{24} & C_{25} \\ C_{31} & C_{32} & C_{33} & C_{34} & C_{35} \\ C_{41} & C_{42} & C_{43} & C_{44} & C_{45} \\ C_{51} & C_{52} & C_{53} & C_{54} & C_{55} \end{bmatrix} \begin{Bmatrix} \bar{A} \\ \bar{B} \\ \bar{C} \\ \bar{D} \\ \bar{E} \end{Bmatrix} = \begin{Bmatrix} 0 \\ 0 \\ 0 \\ 0 \\ 0 \end{Bmatrix} \quad (29)$$

The eigenvalue equations are solved by imposing the non-trivial solutions condition and equating the determinant of the characteristic matrix  $[C_{ij}]$  to zero. Expanding this determinant, a polynomial in even powers of  $\omega$  is obtained

$$\beta_0 \omega^{10} + \beta_1 \omega^8 + \beta_2 \omega^6 + \beta_3 \omega^4 + \beta_4 \omega^2 + \beta_5 = 0 \quad (30)$$

where  $\beta_i$  ( $i = 0, 1, 2, 3, 4, 5$ ) are some constants. Eq. (30) is solved five positive and five negative roots are obtained. The five positive roots obtained are the natural angular frequencies of the cylindrical shell in the  $x, \theta$  and  $z$  directions. The smallest of the five roots is the natural angular frequency studied in the present study.

## VI. RESULTS AND DISCUSSION

In this paper studies are presented on the vibration of functionally graded (FG) cylindrical shell. The functionally gradient material (FGM) considered is composed of stainless

steel and nickel and its properties are graded in the thickness direction according to the volume fraction power-law distribution. The influence of constituent volume fractions is studied by varying the volume fractions of the stainless steel and nickel. This is carried out by varying the value of the power law exponent  $N$ . The effects of the FGM configuration are studied by studying the frequencies of FG cylindrical shells. Type FG cylindrical shell has Nickel on its inner surface and stainless steel on its outer surface. The material properties for stainless steel and nickel, calculated at  $T = 300K$ , are presented. Tables 1 and 2 show the variations of the volume fractions  $V_f$  of Nickel and Stainless Steel, respectively, in the thickness direction  $z$  for a FG cylindrical shell. the volume fraction for Nickel  $V_{fN}$  decreased from 1 at  $z = -0.5h$  to 0 at  $z = 0.5h$  and the volume fraction of Stainless Steel  $V_{fss}$  increased from 0 at  $z = -0.5h$  to 1 at  $z = 0.5h$ .

TABLE I

VARIATIONS OF THE VOLUME FRACTIONS  $V_{fss}$ , IN THE THICKNESS DIRECTION $z$  FOR A FG CYLINDRICAL SHELL

$z$	$V_{fss}$					
	$N=0.5$	$N=0.7$	$N=1$	$N=2$	$N=5$	$N=15$
-0.5h	0	0	0	0	0	0
-0.4h	0.3162	0.1995	0.1	0.01	0.00001	$10^{-15} \times 1$
-0.3h	0.4472	0.3241	0.2	0.04	0.00032	$10^{-11} \times 3.27$
-0.2h	0.5477	0.4305	0.3	0.09	0.00243	$10^{-8} \times 1.43$
-0.1h	0.6324	0.5265	0.4	0.16	0.01024	0.0000107
0	0.707	0.6155	0.5	0.25	0.03125	0.00003051
0.1h	0.7745	0.6993	0.6	0.36	0.07776	0.0004701
0.2h	0.8366	0.7790	0.7	0.49	0.1680	0.004747
0.3h	0.8944	0.8553	0.8	0.64	0.3276	0.03518
0.4h	0.9486	0.9289	0.9	0.81	0.5904	0.20589
0.5h	1	1	1	1	1	1

TABLE II

VARIATIONS OF THE VOLUME FRACTIONS  $V_{fN}$ , IN THE THICKNESS DIRECTION $z$  FOR A FG CYLINDRICAL SHELL

$z$	$V_{fN}$					
	$N=0.5$	$N=0.7$	$N=1$	$N=2$	$N=5$	$N=15$
-0.5h	1	1	1	1	1	1
-0.4h	0.6837	0.8004	0.9	0.99	0.9999	1
-0.3h	0.5527	0.6758	0.8	0.96	0.9996	1
-0.2h	0.4522	0.5694	0.7	0.91	0.9975	0.9999
-0.1h	0.3675	0.4734	0.6	0.84	0.9897	0.9999
0	0.2928	0.3844	0.5	0.75	0.9687	0.9999
0.1h	0.2254	0.3006	0.4	0.64	0.9222	0.9995
0.2h	0.1633	0.2209	0.3	0.51	0.8319	0.9952
0.3h	0.1055	0.1449	0.2	0.36	0.6723	0.9648
0.4h	0.0513	0.0710	0.1	0.19	0.4095	0.7941
0.5h	0	0	0	0	0	0

## REFERENCES

- [1] Arnold, R.N., Warburton, G.B., 1948. Flexural vibrations of the walls of thin cylindrical shells. Proceedings of the Royal Society of London A; 197:238-256.
- [2] Ludwig, A., Krieg, R., 1981. An analysis quasi-exact method for calculating eigen vibrations of thin circular shells. J. Sound vibration; 74,155-174.
- [3] Chung, H., 1981. Free vibration analysis of circular cylindrical shells. J. Sound vibration; 74, 331-359.
- [4] Soedel, W., 1980. A new frequency formula for closed circular cylindrical shells for a large variety of boundary conditions. J. Sound vibration; 70,309-317.
- [5] Forsberg, K., 1964. Influence of boundary conditions on modal characteristics of cylindrical shells. AIAA J; 2, 182- 189.
- [6] Lam, K.L., Loy, C.T., 1995. Effects of boundary conditions on frequencies characteristics for a multi-layered cylindrical shell. J. Sound vibration; 188, 363-384.
- [7] Loy, C.T., Lam, K.Y., 1996. Vibration of cylindrical shells with ring support. I. Journal of Impact Engineering; 1996; 35:455.
- [8] Koizumi, M., 1993. The concept of FGM Ceramic Transactions, Functionally Gradient Materials.
- [9] Makino A, Araki N, Kitajima H, Ohashi K. Transient temperature response of functionally gradient material subjected to partial, stepwise heating. Transactions of the Japan Society of Mechanical Engineers, Part B 1994; 60:4200-6(1994).
- [10] Anon, 1996. FGM components: PM meets the challenge. Metal powder Report. 51:28-32.