

An Overview of Islanding Detection Methods in Photovoltaic Systems

Wei Yee Teoh, Chee Wei Tan

Abstract—The issue of unintentional islanding in PV grid interconnection still remains as a challenge in grid-connected photovoltaic (PV) systems. This paper discusses the overview of popularly used anti-islanding detection methods, practically applied in PV grid-connected systems. Anti-islanding methods generally can be classified into four major groups, which include passive methods, active methods, hybrid methods and communication base methods. Active methods have been the preferred detection technique over the years due to very small non-detected zone (NDZ) in small scale distribution generation. Passive method is comparatively simpler than active method in terms of circuitry and operations. However, it suffers from large NDZ that significantly reduces its performance. Communication base methods inherit the advantages of active and passive methods with reduced drawbacks. Hybrid method which evolved from the combination of both active and passive methods has been proven to achieve accurate anti-islanding detection by many researchers. For each of the studied anti-islanding methods, the operation analysis is described while the advantages and disadvantages are compared and discussed. It is difficult to pinpoint a generic method for a specific application, because most of the methods discussed are governed by the nature of application and system dependent elements. This study concludes that the setup and operation cost is the vital factor for anti-islanding method selection in order to achieve minimal compromising between cost and system quality.

Keywords—Active method, hybrid method, islanding detection, passive method, photovoltaic (PV), utility method

I. INTRODUCTION

OVER the past decades, the rapid fall of the PV manufacturing cost has led to the fast development of PV energy system. This has made PV one of the most promising renewable energy resources in distributions generation (DG) [1]. In addition, solar energy is free and pollution free [2]. In grid-connected PV systems particularly, the connection of PV array and balance of system to the utility grid has to fulfill the technical requirement of interconnection from the utility grid. This is to ensure high power quality; substantial safety interaction and reliability of the utility are achieved. Therefore, abnormal operating conditions that could affect the grid-connected PV systems have to be prevented [3]. One of the major safety issues related is the challenge to avoid unintentional island mode of operation. An islanding mode is a condition in a DG which the energy resource continues to

supply to the local load even though the utility grid has been disconnected from the local load [3, 4]. Islanding mode of operation causes the utility grid to be disconnected from the DG in order to prevent any damage in the system. Under this condition, the grid is no longer servicing as a solid voltage and frequency reference. A general concept of islanding formation is illustrated in Fig. 1. During islanding mode, the utility circuit breaker is opened while the DG is still injecting power to supply the local load (the section between utility circuit breaker and the point of common coupling, PCC) [3, 4]. This phenomenon occurs when utility suffers from unpredictable interruption of abnormality, such as voltage shut-down, short-circuit or equipment failure [5].

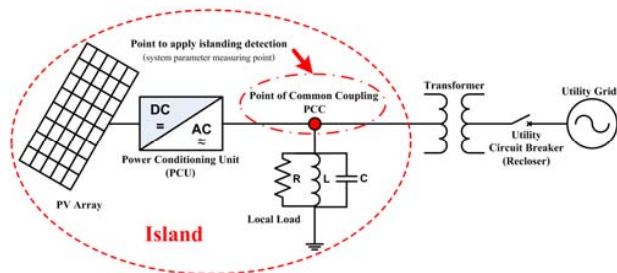

Fig. 1 An overview of islanding mode in a grid connected PV system

There are two types of islanding modes, namely the intentional (planned) and the unintentional (unplanned) islanding [4, 6]. The purpose of intentional islanding is to sectionalize the utility system in order to create a power 'island' during an occurrence of disturbance. This is a common scenario especially for maintenance purposes. The local load in the created island will be supplied constantly by DG through a well-planned energy management until the utility is ready to be synchronized with the DG. Typically, intentional islanding is harmless to the power system because the problem can be solved during or after the grid disconnection [6]. However, unintentional islanding can create a severe impact to the power system stability due to the loss of grid synchronization. Consequently, this causes the DG to be out of the voltage and frequency references. This may damage the electrical devices and systems equipment in the islanded section.

Another issue persists in the islanding mode whereby the technical workers may be placed under safety hazards as they may not be aware that the section is continuously powered by the DG. For this reason, anti-islanding control is essential in order to detect the islanding operation immediately.

Wei Yee Teoh and Chee Wei Tan are with Department of Energy Conversion (ENCON), Faculty of Electrical Engineering, Universiti Teknologi Malaysia, 81300 Skudai, Johor, West Malaysia. (e-mail: weiyee@fkegraduate.utm.my, cheewei@fke.utm.my Tel: +6 07-5535768 Ext: 35768)

Subsequently, control signal should be sent to alert the entire system to perform disconnection of DG from the local load [7].

Various anti-islanding algorithms and detection methods have been developed [8]. The methods can briefly be classified into two families, namely local islanding detection techniques and remote islanding detection techniques. The former method relies on the measurement of system parameters at the DG while the latter is based on the communication between the utility grid and the DG. The other control techniques under the two main families are summarized in Fig. 2 which shows the hierarchy of anti-islanding detection [7, 9, 10]. According to the information gathered from literature review, none of the islanding detection methods is perfect. Some limitations may include:

- i. presence of non-detected zone (NDZ) causing possible anti-islanding detection failure,
- ii. degradation of power quality and system stability,
- iii. false operation in multiple DG,
- iv. requirement of additional circuitry or equipment,
- v. high implementation cost [11].

Therefore, further research and development on anti-islanding detection algorithm still need to be sought to minimize the pitfall of the assisting techniques.

The aim of this paper is to review the common practically used anti-islanding detection techniques in PV grid-connected systems. The operation theory of each islanding detection method under active, passive, communication and hybrid methods will be described in the next section. Besides that, comparison is made based on the advantages and disadvantages of the discussed detection methods. Finally, a conclusion is drawn.

II. ISLANDING DETECTION METHOD

For better understanding of islanding phenomena, two key features have to be highlighted. The first feature is the non-detected zone (NDZ) and the second is the quality factor (Q factor) [12, 13]. Both features have been extensively used as the criteria to evaluate the effectiveness of islanding detection methods. The NDZ represents the interval of islanding failed to be detected by the DG once islanding occurred [11]. This region relates to the power mismatch between DG generating power and local load consuming power, therefore creating a real power variation (ΔP) and reactive power variation (ΔQ). For this reason, the variations must be significant in order to detect islanding within permitted time interval. Therefore, NDZ is defined as an evaluation index for an islanding detection method.

The second feature, which is the Q factor, is defined in [3] as two π times the ratio of the maximum storage energy to the energy dissipated per cycle at a given frequency. It demonstrates the relative amount of energy storage and energy dissipation in the RLC circuit. A high Q factor may impede effectiveness of islanding detection, whilst value of Q factor is

directly affected by potential local load inside the island. The load can be modeled as a parallel RLC load due to the difficulty in islanding detection. Comparatively, non-linear loads, such as harmonics producing load that produce a current harmonic and constant power loads that produce constant power, does not cause much difficulty in islanding detection. In particular, most of the islanding methods face the problem of the NDZ especially when using the passive islanding detection method. The quality factor is proportional to the NDZ, which means that a higher quality factor would generate a larger NDZ, hence the smaller the NDZ is preferred [14]. Therefore, reducing the NDZ and improving the time response of islanding detection have become the core research area nowadays.

Anti-islanding mode control techniques for PV source DG can be classified into two families, local detection and remote detection techniques. Under the two sub-components, there are many other control techniques which can be classified based on each detection methodology. The overall mapping of anti-islanding techniques is shown in Fig. 2. The detail operation of islanding detection methods are described in the following sub-sections.

A. Passive Methods

Passive islanding detection methods relies on the measurement of system parameters (such as the variation in the voltage, frequency, harmonic distortion or the power) that causes the inverter to control/modify the output power in order to meet specific conditions during islanding mode of operation [15]. The parameters vary greatly at the point of the PCC when the system is islanded. The difference between a normal grid-connected condition and an islanding condition is based on the threshold setting of the system parameters [15]. Fig. 3 shows the basic operation flow of passive islanding detection procedure. Extreme care should be taken while setting the value of threshold in order to differentiate islanding operation from other disturbances in the controlled system. In general, passive detection techniques are fast and create no disturbance in the system, however it has a large NDZ which could fail the islanding detection [16].

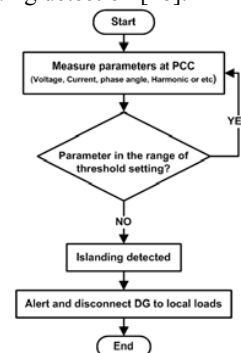

Fig. 3 The flow chart of passive islanding detection procedure

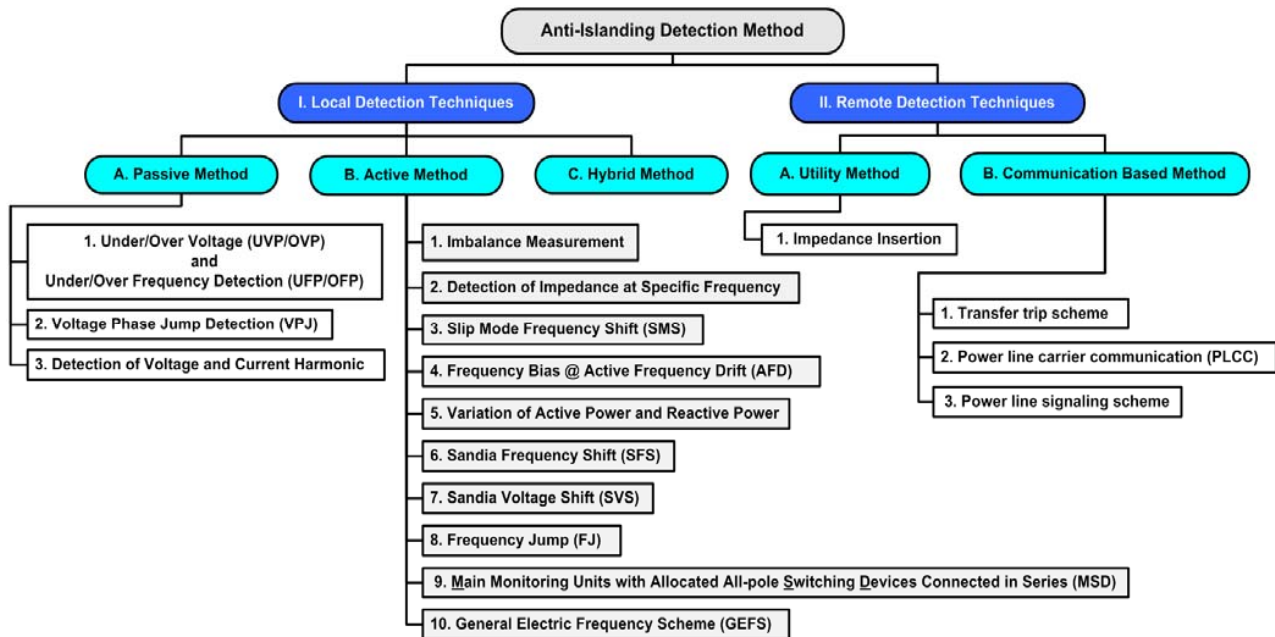

Fig. 2 The classification of anti-islanding detection techniques

1. Frequency Protection and Voltage Protection

The under/over frequency protection (UFP/OFD) and under/over voltage protection (UVP/OVP) methods are also known as the standard protective relay or abnormal voltage detection. This method is used as a basic protection for the PV grid-connected system [5]. The OFD/UFP and OVP/UVP methods are essential to all grid-connected PV systems. This is to ensure that the DG stops injecting power to the utility in the case of the PCC voltage amplitude or the frequency exceeding the defined thresholds. Besides protection, the OFD/UFP and OVP/UVP methods also serves as anti-islanding detection method [17]. The power flow in a PV grid-connected system is presented in Fig. 4, which the node PCC is the point of common coupling between the utility grid and power conditioning unit.

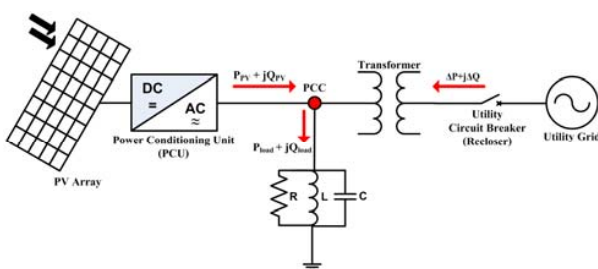

Fig. 4 The power flow in a PV grid-connected system under a normal operating condition

During islanding mode of operation, the control system should be able to maintain the active power demand for the local load equivalent to the power generated by PV at the moment when the utility circuit breaker is opened. In case the power generated by PV, P_{pv} is less than the load power, P_{load} ,

the voltage at PCC, V_{PCC} has to be increased to achieve equivalent input and output power, vice and versa. Similarly, if the reactive power of local load does not match the reactive power generated from PV, the frequency, ω at the PCC has to be controlled to make both reactive power equivalents. The PV inverter continuously seeks for a frequency at which the current-voltage phase angle of the local load is equal to the PV system. Therefore, such voltage and frequency changes can be detected by over/under voltage and over/under frequency relays [18]. However, if the local load and the PV generation are close together, it would be very difficult to detect islanding operation due to a very small value of power change. In addition, the response time of this detection method varied [19], hence the OVP/UVP protection will not trigger the system to prevent islanding accurately.

2. Voltage Phase-Jump Detection

The voltage phase-jump detection (PJD) method is performed by monitoring the phase difference between the inverter's terminal voltage (V_{PCC}) and its output current (I_{PV_inv}) for a sudden phase jump as shows in Fig. 5 [19]. In the occurrence of islanding, during the transition from normal operation to islanding mode, the phase angle of V_{PCC} will shift to match the phase angle of the local load. This results in a sudden phase change to the PCC. The PJD method will search for this rapid change of phase angle in order to detect islanding. In addition to that, load commonly has non-unity power factor, which means that voltage from the utility grid is not absorbed entirely but it is slightly impeded [8].

Typically, the inverter in PV systems tracks the phase of the grid signal using phase locked loop (PLL) [20-22]. For current source inverters, the output current waveform of the inverter will be synchronized to the utility voltage by detecting the rise

or fall of V_{PCC} zero crossing at the PCC under normal operation. This can be accomplished by using an analog or digital PLL. For voltage-source inverters, the role of the voltage and current are swapped as in the current source inverter [23].

In short, it is essential for grid-connected inverters to have unity power factor because the NDZ of the PJD method solely depends on the power factor; while the power factor depends on the local load during islanding of operation [23]. The NDZ may change if the inverter does not operate under unity power factor [13]. Thus, the PJD method is also known as the power factor detection or transient phase detection [5].

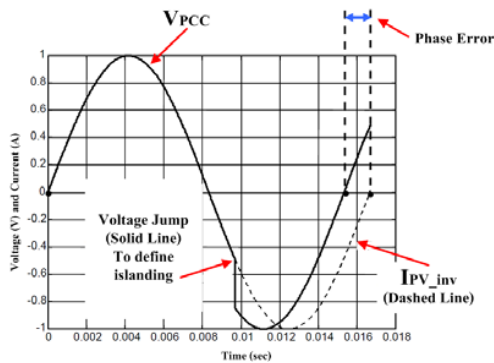

Fig. 5 The operation of voltage phase-jump detection.

3. Others Passive Islanding Detection Methods

There are many other passive methods, including the detection of voltage and current harmonic technique. This method monitors the change of the total harmonic distortion, THD at the PCC [24]. A very good detection method which changes the third harmonic of the V_{PCC} during islanding has been reported in [25]. The comparison of the measured value and the defined threshold in the case that the threshold is exceeded is described in the literature [9].

Besides that, a new passive anti-islanding method has been proposed by [26], which is known as the detection based on state estimators method. The basic idea of this method is based on the application of a voltage oriented control combined with resonant controllers.

Another algorithm which is based on the Kalman filters was proposed to estimate the third and the fifth harmonics of the grid voltages. The corresponding energy mismatch between the estimated third and fifth harmonics, and the measured values are used to detect islanding condition [9]. Reference [27] details a new passive method known as the detection of voltage unbalance and total harmonic distortion. This method uses two parameters in the detection of islanding, namely the voltage unbalance and the THD of the current. However, this method does not solve the problem of difficulty in the high Q factor detection plus the threshold is not easy to determine [28].

B. Active Methods

Active islanding detection method is based on the injection of a small disturbance signal to certain parameters at the PCC [28]. The concept of this method is that small disturbance signal will become significant upon entering the islanding mode of operation in order to help the inverter to cease power conversion. Hence, the values of system parameter will be varying during the cessation of power conversion, and by measuring the corresponding system parameters, islanding condition can be detected [10], as shown in Fig. 6.

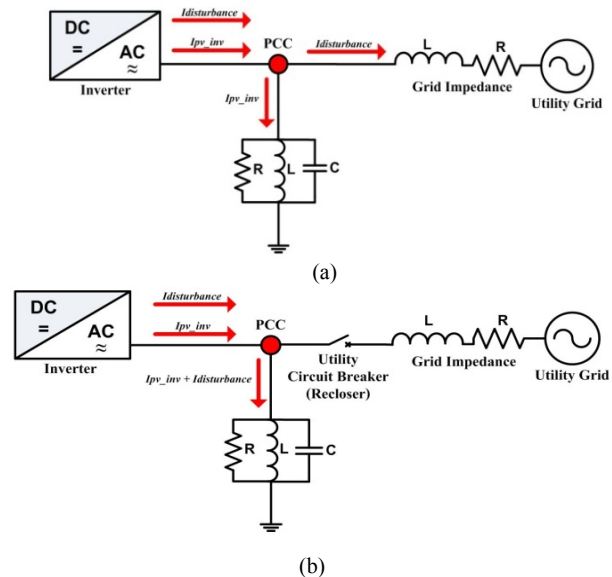

Fig. 6 The path of disturbance signals during an islanding condition, (a) before the circuit breaker is opened, (b) after the circuit breaker is opened.

Active methods involve feedback control technique that detects changes in the parameters such as frequency or voltage at the PCC [7]. In the case when the PV inverter behaves as a current source, the current supplied to the utility is expressed by the following equation.

$$i_{PV_inv} = I_{PV_inv} \sin(\omega_{PV} + \phi_{PV}) \quad (1)$$

Where I_{PV_inv} is the inverter current amplitude ($i_{PV_inv} = I_{PV_inv} + I_{disturbance}$), ω_{PV} is the frequency and ϕ_{PV} is phase angle. These three parameters can be varied and modified, or can be set as disturbance signals.

Fig. 7 shows the operation of power flow in active islanding detection. Active methods can effectively reduce, even eliminate, the NDZ and detect islanding accurately. However, this method requires additional control circuits to create adequate disturbances which increase the complexity for implementation. Nevertheless, additional circuits may cause unpredicted effects to the electric power quality, such as the deterioration of the grid voltage quality and system instability [5].

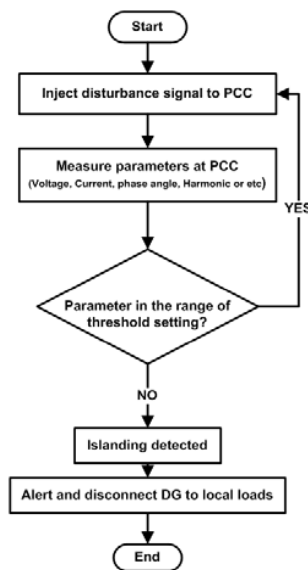

Fig. 7 The flow chart of active islanding detection procedure.

1. Sandia Frequency Shift

Sandia Frequency Shift (SFS) method, commonly known as Active Frequency Drift with Positive Feedback (AFDPF), is a new method improved from Active Frequency Drift (AFD) [29]. SFS using positive feedback by creating a slightly misaligned phase angle at inverter output current through adding truncations or dead times to the current's waveform. Hence, the inverter output current frequency will be forced to a different value than the grid's frequency [30-32]. The chopping frequency expressed in (2) is determined to be a function of error in the grid frequency.

$$Cf = Cf_0 + K(f_a - f_{line}) \quad (2)$$

Where Cf_0 is the chopping, K is an accelerating gain, f_a is the measured frequency of V_{PCC} , and f_{line} is the line frequency.

When the utility grid is connected, Cf is low because the utility grid will stabilize the V_{PCC} by providing a solid phase and frequency reference. Once the utility grid is disconnected, phase error arise between V_{PCC} and i_{PV-inv} waveforms [28]. This causes the PV inverter to increase the frequency of i_{PV-inv} in order to eliminate the phase error. The voltage response of load again has its zero crossing advanced in time with respect to where it was expected to be, at which times the PV inverter still detects a phase error and keep increases its frequency [5]. This results in increase in the value of Cf , until the frequency has drifted far enough from ω_0 to be detected by the OVP/UVP, and finally stops inverter operation.

2. Sandia Voltage Shift

Sandia Voltage Shift (SVS) uses positive feedback technique to prevent islanding based on amplitude of voltage at PCC. When the utility grid is connected, there will be very

small or no effect on the power of the system. But once the utility is disconnected, there is reduction in V_{PCC} . According to load impedance's relationship, this reduction will continue and as a result, current and power output reduces. Therefore, this reduction in amplitude of V_{PCC} can be detected by UVP. It is possible either to increase or decrease the power output of the inverter, leading to corresponding OVP/UVP to trip and stops inverter operation [5, 23, 28].

3. Others Active Methods

There are many other active methods developed. For example, Impedance Measurement is to measure the overall impedance of the circuit being fed by the inverter. Inverter supplies a current source I_{PV-inv} through the utility together with an injection of excessive current at a given time [15, 23, 28, 33]; Detection of impedance at special frequency method is done by injecting a current harmonic of a specific frequency intentionally into PCC via the PV inverter [16, 23]; Slip Mode Frequency Shift (SMS) is the method forcing the phase of the inverter's output to be slightly mis-aligned with the grid to cause variation in the inverter current [15, 23, 28]; Frequency bias or AFD, is a method that forces a slightly frequency bias signal into the grid via PCC, but recover this at the end of every half cycle by jumping back into phase when the voltage passes zero crossing [5, 23, 28, 29]; Frequency Jump is a modification of the frequency bias method but this method inserts a dead zone into output current waveform only on a specific number of cycles [5, 16]; Main Monitoring Units with Allocated All-pole Switching Devices Connected in Series (MSD) is a multiple detection method depends on detection of the grid impedance by using two monitoring devices simultaneously [5, 9]. Variation of active power and reactive power method involve injection of active and reactive power from the inverter into the utility system [5, 9].

C. Hybrid Methods

Hybrid method is evolved from the combination of both active and passive detection methods [15, 28]. The hybrid methods involves two stages of detecting procedures to overcome the problems of passive method and active method, in order to achieve higher effectiveness [34]. During the detecting procedure passive detection method is used as primary protection, then the active detection method is implemented when the islanding is suspected by the passive method [15]. Fig. 8 shows the basic operation flow for hybrid islanding detection procedures.

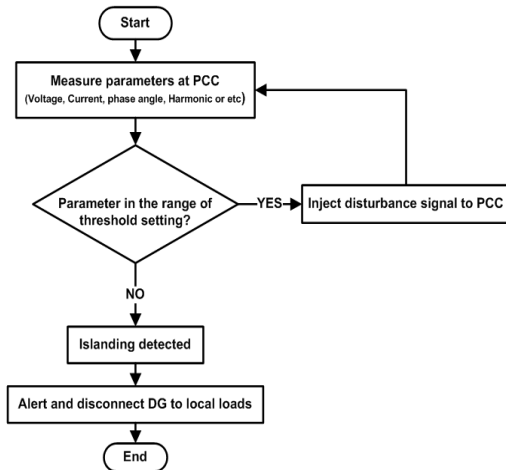

Fig. 8 The flow chart describing the process of a hybrid islanding detection procedure.

According to literatures, most of the hybrid methods proposed are mainly applied in synchronous machine and three phase system. For example, hybrid methods proposed in [34-36]. Some others hybrid methods are using multiple system parameter to identify any possibility of islanding operation based on data mining and artificial intelligence, such as methods proposed in [37, 38]. Method proposed in [39], applies a combinations of UFP/OFD, UVP/OVP, SFS and SVS methods. Although hybrid methods provide better effectiveness at detecting islanding, but currently, only Japan requires renewable energy source DG systems to have at least one passive and one active islanding detection method implemented in a DG system [40]. This is because most of the proposed methods are still in the research and development stage, yet to reach practical implementation in real systems.

D. Communication Base Methods

Communication base methods are based on communication between utilities and DG [15]. Islanding is detected when the status of utility circuit breaker and the information was send to DGs. These methods require telecommunication system to be equipped to alert DG when islanding occurs, then DG will take action to trip from local load. These techniques are more accurate and have better reliability than local islanding detection techniques, but the need for communication equipment which are expensive, make these methods uneconomical to implement [39].

1. Transfer Trip Scheme

Transfer trip scheme is cooperated with Supervisory Control and Data Acquisition (SCADA) system to monitor the status of circuit breakers and recloser at utility grid which could island a DG in a distribution system [41]. Hence, this method also commonly known as SCADA islanding detection

method [5]. The method requires a good interaction between the utility and DG, so that necessary action can be taken in the event of any abnormalities in the system [28]. When a PV inverter is installed, the use of SCADA for islanding prevention is straight forward: by installing voltage-sensing devices in the local parts of the utility system. If these sensors detect a voltage at a time when the utility source is disconnected from that part of the system, a series of alarms will alert the DG and corrective action will be taken. In additional, the same system can also to be used at the same time to provide signal for reconnecting the DGs once fault clearance is confirmed [42].

2. Power Line Carrier Communication (PLCC)

Power Line Carrier Communications (PLCC) system relies on communication channel in the utility power line. The basic operation of PLCC is to send a low-energy signal between the transmitter (T) installed on the utility side and receiver (R) install on the DG side [43]. When islanding occurs, this communication signal will be disrupted. In response the receiver will sends a stopping signal to the PCU or a switch to isolate the load from the DG [43, 44].

Fig. 9 shows an example of a system configuration that includes a power line carrier method for islanding prevention. There is a possibility to use the PLCC signal to perform a continuity test of the line, because the line is used as the communications channel. A PLCC transmitter (T) sends a signal along the power line to a receiver (R). When a PLCC signal is provided, a simple device acting as a receiver is installed on the customer side of the PCC which can detect the presence or absence of the PLCC signal. Thus, if the PLCC signal disappears, this indicates a break in the continuity of the line and the PCU can be instructed to cease operation in order to meet desired power output to the load or open its own switch to isolate the load from DG [9][6].

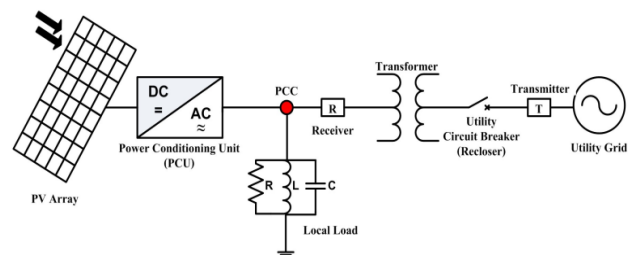

Fig. 9 Topology of power line carrier communication control with transmitter (T) and receiver (R) added to the system.

III. COMPARISONS AND DISCUSSIONS

Based on literatures, all methods meet the detection time required by IEEE 929 and IEEE 1547 standard. Various standards of requirement of anti-islanding protection are

TABLE 1
A COMPARISON OF ISLANDING DETECTION METHOD BASED ON VARIOUS CHARACTERISTICS

Characteristic	Local Method			Remote Method	
	Passive	Active	Hybrid	Utility	Communication
Principle of operations	Uses monitoring of local voltage, current, frequency and harmonic sensing at PCC	Used disturbance signal injection from DG to drive the operating point of the system towards to the frequency/voltage trip limits.	Combination of passive and active method	Based on install specific equipment such as impedance at the utility side to modify the impedance that can be seen at the PCC during islanding occurs.	Used communication between the grid and DGs by install communication equipment,
NDZ	Large	Small	Small	None	None
Response Time	Short	Slightly shorter than passive method	Longer than active method	Fast	Faster
Operation failure	Possible if not proper to select trip threshold when small power mismatch between utility and local load.	Possible in high Q-factor	Possibility lower than only use passive or active method	Possible if the value of impedance sized out of the minimum variation of phase.	Impossible if occurs of Ferro-resonant
Effect on Distribution System	None	Direct influence on power system such as voltage fluctuation	Lower than Active method	None	None
System cost	Low (Minimal Hardware)	Medium (Required additional equipment and circuitry)	High	Very high	Extremely High
Effectiveness	Depends on consume and supply condition (Less efficient on source-load balanced condition)	Effective (can detect islanding even in source-load balance condition)	Very effective	Very effective	Most effective
Multiple DGs operation	Possible	Not possible	Possible	Possible	Possible
Influence by The Number of Connected Inverter	None	Yes	Yes	None	None
Effect on power quality	No degradation	Degraded (Reduced power quality, system transient response, voltage stability and others)	Degraded but much more lower than active method	No degradation	No degradation

described in [3-6, 11, 45, 46]. Table 1 shows the comparison based on islanding detection method characteristics. The table indirectly shows the common advantages and disadvantages of passive, active, hybrid and remote methods.

Passive method is the basic requirement of grid connected DG because this method is economical and practical. In addition, passive methods cause no degradation to power quality and are easily implemented. The drawbacks of passive methods are the large NDZ and difficulties of threshold setting. Moreover, passive method is not guaranteed for all load conditions, especially in load-source balance condition. Active methods are developed to reduce NDZ of passive methods, thus most of the active methods have very small NDZ (even eliminated) compared to passive methods, except in cases of high Q factor loads. But the concept behind the active methods is to drive the operation point of the system towards UFP/OFP and UVP/OVP trip limits, by destabilizing the system. Consequently, active methods can degrade the system stabilization and power quality. This issue will become

more significant when more inverters are connected in same DG. In this paper, it can be observed that active methods are heavily emphasized in most of the research and development on detection method. Current PV grid connected systems are mostly applied in small scale basis to render the deteriorating effects of using active detection methods less significant. Currently among all active methods, SVS and SFS methods are considered the most effective methods for PV based DG [10]. Both methods are commonly applied simultaneously to offer the highest effectiveness and smallest power degradation. Furthermore, SVS and SFS are not difficult to implement.

For large PV grid connected system, passive method and communication based methods will be the preferred choice. The reason is that these methods provide good power quality as their operation principle is not dependent on destabilizing the system to detect islanding. On the other hand, the drawback of passive methods is the presence of a large NDZ and in some cases may cause failure in detection. Hence, high

concern should be given to the setting of correct detection threshold value for passive methods to avoid mal-function.

Communication base detection has perfect performance but the system and operation cost is extremely high, due to the additional telecommunication devices and sensors installed at utility side. Hence, these methods are usually applied to large scale systems with sensitive load, where power quality and system stabilization are highlighted instead of system cost. Therefore, with the objective to solve problems of those three common methods, hybrid detection methods have been proposed to reduce NDZ, provide better power quality and cheaper system cost. Yet, at the moment hybrid methods are not implemented in real systems except Japan [47]. Because most of the methods are still in proposal level and more researches have to be done, in order to ensure the method can be implemented widely in real system application.

IV. CONCLUSION

The overview of several possible islanding detection methods suitable for PV grid-connected system have been discussed and analyzed. As a conclusion, it is difficult to define a generic method for a specific application, because most of the methods discussed are governed by the nature of application and system dependent elements. In addition, the setup and operation cost is always the vital factor for anti-islanding method. Hence, careful selection has to be made based on the understanding of the actual history of islanding probability occurrence in a particular system. This is to ensure that the control system is reliable as well as achieving minimal compromising between cost, system quality and safety risks. In fact, the choice of anti-islanding methods is dependent on national electrical rules and regulations, because every country has its own guidelines of DG interconnection requirements.

ACKNOWLEDGMENT

The authors would like to express the greatest gratitude to the sponsorship of the this research funding, the Science Fund, granted by the Ministry of Science, Technology & Innovation Malaysia under the vote of 79377.

REFERENCES

- [1] Mulhausen, J., et al. *Anti-islanding today, successful islanding in the future*. in *Protective Relay Engineers, 2010 63rd Annual Conference for*. 2010.
- [2] Thomas Ackermann, Göran Andersson, and Lennart Söder, *Distributed generation: a definition*. Electric Power Systems Research, 2001. **57**(3): p. 195-204.
- [3] *IEEE Recommended Practice for Utility Interface of Photovoltaic (PV) Systems*, in *IEEE Std 929-2000*2000.
- [4] IEEE, *IEEE Application Guide for IEEE Std 1547, IEEE Standard for Interconnecting Distributed Resources with Electric Power Systems*. IEEE Std 1547.2-2008, 2009: p. 1-207.
- [5] IEA International Energy Agency, *Evaluation of Islanding Detection Methods for Photovoltaic Utility Interactive Power systems*, in *Task V Report IEA PVPS T509: 2002*2002.
- [6] IEEE, *IEEE Standard for Interconnecting Distributed Resources With Electric Power Systems*. IEEE Std 1547-2003, 2003: p. 0_1-16.
- [7] Funabashi, T., K. Koyanagi, and R. Yokoyama. *A review of islanding detection methods for distributed resources*. in *Power Tech Conference Proceedings, 2003 IEEE Bologna*. 2003.
- [8] Singam, B. and L.Y. Hui. *Assessing SMS and PJD Schemes of Anti-Islanding with Varying Quality Factor*. in *Power and Energy Conference, 2006. PECon '06. IEEE International*. 2006.
- [9] Velasco, D., et al., *Review of anti-islanding techniques in distributed generators*. Renewable and Sustainable Energy Reviews, 2010. **14**(6): p. 1608-1614.
- [10] Noor, F., R. Arumugam, and M.Y. Vaziri. *Unintentional islanding and comparison of prevention techniques*. in *Power Symposium, 2005. Proceedings of the 37th Annual North American*. 2005.
- [11] Wilsun Xu, Konrad Mauch, and Sylvain Martel, *An Assessment of Distributed Generation Islanding Detection Methods and Issues for Canada*. report # CETC-Varenes 2004-074 (TR), CANMET Energy Technology Centre – Varennes, Natural Resources Canada, July 2004, 53 pp., 2004.
- [12] Xuancai, Z., et al. *Analysis of the Non-detection Zone with Passive Islanding Detection Methods for Current Control DG System*. in *Applied Power Electronics Conference and Exposition, 2009. APEC 2009. Twenty-Fourth Annual IEEE*. 2009.
- [13] Zhihong, Y., et al., *Evaluation of anti-islanding schemes based on nondetection zone concept*. Power Electronics, IEEE Transactions on, 2004. **19**(5): p. 1171-1176.
- [14] De Mango, F., et al. *Overview of Anti-Islanding Algorithms for PV Systems. Part I: Passive Methods*. in *Power Electronics and Motion Control Conference, 2006. EPE-PEMC 2006. 12th International*. 2006.
- [15] Pukar Mahat, Chen Zhe, and Birgitte Bak-Jensen. *Review of islanding detection methods for distributed generation*. in *Electric Utility Deregulation and Restructuring and Power Technologies, 2008. DRPT 2008. Third International Conference on*. 2008.
- [16] Trujillo, C.L., et al., *Analysis of active islanding detection methods for grid-connected microinverters for renewable energy processing*. Applied Energy, 2010. **87**(11): p. 3591-3605.
- [17] Doumbia, M.L., K. Agbossou, and T.K. Bose. *Islanding protection evaluation of inverter-based grid-connected hybrid renewable energy system*. in *Electrical and Computer Engineering, 2004. Canadian Conference on*. 2004.
- [18] Skocil, T., et al. *Passive and active methods of islanding for PV systems*. in *Power Electronics and Applications, 2009. EPE '09. 13th European Conference on*. 2009.
- [19] Aljankawey, A.S., et al. *Passive method-based islanding detection of Renewable-based Distributed Generation: The issues*. Electric Power and Energy Conference (EPEC), 2010 IEEE 2010 25-27 Aug. 2010; 1-8].
- [20] Best, R., *Phase-Locked Loops: Theory, Design, and Applications*. 2nd ed1993: McGraw-Hill Inc.
- [21] Brennan, P.V., *Phase-Locked Loops: Principles and Practice*1996: MacMillan Press Ltd.
- [22] Guan-Chyun, H. and J.C. Hung, *Phase-locked loop techniques. A survey*. Industrial Electronics, IEEE Transactions on, 1996. **43**(6): p. 609-615.
- [23] Ward Bower and M. Ropp., *Evaluation of Islanding Detection Methods for Utility-Interactive Inverters in Photovoltaic Systems*, in *SAND2002-3591 Unlimited Release*2002.
- [24] Jang, S.I. and K.H. Kim. *A new islanding detection algorithm for distributed generations interconnected with utility networks*. in *Developments in Power System Protection, 2004. Eighth IEE International Conference on*. 2004.
- [25] Kobayashi, H., et al. *Method for preventing islanding phenomenon on utility grid with a number of small scale PV systems*. in *Photovoltaic Specialists Conference, 1991., Conference Record of the Twenty Second IEEE*. 1991.
- [26] Liserre, M., et al., *An Anti-Islanding Method for Single-Phase Inverters Based on a Grid Voltage Sensorless Control*. Industrial Electronics, IEEE Transactions on, 2006. **53**(5): p. 1418-1426.
- [27] Sung-II, J. and K. Kwang-Ho, *An islanding detection method for distributed generations using voltage unbalance and total harmonic distortion of current*. Power Delivery, IEEE Transactions on, 2004. **19**(2): p. 745-752.
- [28] Kunte, R.S. and G. Wenzhong. *Comparison and review of islanding detection techniques for distributed energy resources*. in *Power Symposium, 2008. NAPS '08. 40th North American*. 2008.

- [29] Lopes, L.A.C. and S. Huili, *Performance assessment of active frequency drifting islanding detection methods*. Energy Conversion, IEEE Transactions on, 2006. **21**(1): p. 171-180.
- [30] Gwon-jong, Y., et al. *Boundary conditions of reactive-power-variation method and active-frequency-drift method for islanding detection of grid-connected photovoltaic inverters*. in *Photovoltaic Specialists Conference, 2005. Conference Record of the Thirty-first IEEE*. 2005.
- [31] Liu, F., Y. Kang, and S. Duan. *Analysis and optimization of active frequency drift islanding detection method*. in *Applied Power Electronics Conference, APEC 2007 - Twenty Second Annual IEEE*. 2007.
- [32] Youngseok Jung, Jaeho Choi, and G. Yu, *A Novel Active Anti-islanding Method for Grid-connected Photovoltaic Inverter*. Journal of Power Electronics, 2007. **Vol. 7, No. 1** p. 64-71.
- [33] Llaría, A., et al., *Survey on microgrids: Unplanned islanding and related inverter control techniques*. Renewable Energy, 2010. **36**(8): p. 2052-2061.
- [34] Wen-Yeau, C. *A hybrid islanding detection method for distributed synchronous generators*. in *Power Electronics Conference (IPEC), 2010 International*. 2010.
- [35] Jun, Y., C. Liuchen, and C. Diduch. *A New Hybrid Anti-Islanding Algorithm in Grid Connected Three-Phase Inverter System*. in *Power Electronics Specialists Conference, 2006. PESC '06. 37th IEEE*. 2006.
- [36] Menon, V. and M.H. Nehrir, *A Hybrid Islanding Detection Technique Using Voltage Unbalance and Frequency Set Point*. Power Systems, IEEE Transactions on, 2007. **22**(1): p. 442-448.
- [37] Ghazi, R. and N. Lotfi. *A new hybrid intelligent based approach to islanding detection in distributed generation*. in *Universities Power Engineering Conference (UPEC), 2010 45th International*. 2010.
- [38] Lei, D., et al. *An Integrated Automatic Control System for Distributed Generation Hierarchical Islanding*. in *Power System Technology, 2006. PowerCon 2006. International Conference on*. 2006.
- [39] Mylène Robitaille, et al., *Islanding Detection Method for a Hybrid Renewable Energy System*. International Journal of Renewable Energy Research, IJRER, 2011. **Vol.1 , No.1, pp.41-53**.
- [40] IEA International Energy Agency, Bas Verhoeven, and K.N. B.V., *Utility Aspects of Grid Connected Photovoltaic Power systems*, in *Task V Report IEA PVPS T5-011998*.
- [41] Redfern, M.A., O. Usta, and G. Fielding, *Protection against loss of utility grid supply for a dispersed storage and generation unit*. Power Delivery, IEEE Transactions on, 1993. **8**(3): p. 948-954.
- [42] Wilsun, X., et al., *A Power Line Signaling Based Technique for Anti-Islanding Protection of Distributed Generators—Part I: Scheme and Analysis*. Power Delivery, IEEE Transactions on, 2007. **22**(3): p. 1758-1766.
- [43] Ropp, M.E., et al. *Using power line carrier communications to prevent islanding [of PV power systems]*. in *Photovoltaic Specialists Conference, 2000. Conference Record of the Twenty-Eighth IEEE*. 2000.
- [44] Ropp, M., et al. *Discussion of a Power Line Carrier Communications-Based Anti-Islanding Scheme using a Commercial Automatic Meter Reading System*. in *Photovoltaic Energy Conversion, Conference Record of the 2006 IEEE 4th World Conference on*. 2006.
- [45] IEEE, *IEEE Recommended Criteria for Terrestrial Photovoltaic Power Systems*, in *ANSI/IEEE Std 928-1986/1986*. p. 0_1.
- [46] IEEE, *IEEE Recommended Practice for Utility Interface of Residential and Intermediate Photovoltaic (PV) Systems*, in *ANSI/IEEE Std 929-1988/1987*. p. 0_1.
- [47] IEA International Energy Agency, et al., *Risk Analysis of Islanding of Photovoltaic Power Systems Within Low Voltage Distribution Networks*. Task V Report IEA PVPS T508: 2002, 2002.