

Power Generation Potential of Dynamic Architecture

Ben Richard Hughes¹ and Hassam Nasarullah Chaudhry

Abstract—The main aim of this work is to establish the capabilities of new green buildings to ascertain off-grid electricity generation based on the integration of wind turbines in the conceptual model of a rotating tower [2] in Dubai. An in depth performance analysis of the WinWind 3.0MW [3] wind turbine is performed. Data based on the Dubai Meteorological Services is collected and analyzed in conjunction with the performance analysis of this wind turbine. The mathematical model is compared with Computational Fluid Dynamics (CFD) results based on a conceptual rotating tower design model. The comparison results are further validated and verified for accuracy by conducting experiments on a scaled prototype of the tower design. The study concluded that integrating wind turbines inside a rotating tower can generate enough electricity to meet the required power consumption of the building, which equates to a wind farm containing 9 horizontal axis wind turbines located at an approximate area of 3,237,485 m² [14].

Keywords—computational fluid dynamics, green building, horizontal axis wind turbine, rotating tower, velocity gradient.

I. INTRODUCTION

BUILDINGS utilize energy in two primary methodologies, first, to keep the interior as contented as achievable through optimizing Heating, Ventilation and Air-Conditioning (HVAC) and secondly, to generate power to run the required domestic applications, all of which leading to an increase in resultant global CO₂ emissions. Buildings are accountable for almost 40% of the global energy consumption and are responsible for approximately half of the world's green house gas emissions [1]. The majority of the world's renewable energy is directed from the sun, but a good percentage is also made up by harnessing the resource of natural wind. The potential of utilizing wind energy in the Middle East demands concentrated research planning, in order to estimate the vast benefits that can be achieved using this natural resource. Utilizing natural ventilation for maintaining satisfactory air quality in the interior is dependent on the supply of fresh air.¹

The quantity of ventilation needed to ensure an adequate air quality indoors depends on the amount of the pollutant in a space. It is known that the pollution level decreases exponentially with the airflow rate. Hence, the ideal airflow rate can be calculated by knowing the pollution intensity of the system [4]. Due to the increasing urbanization rate in

Dubai, significant energy consumption is utilized by high-rise building structures. However, with the advances in research into new technology for more efficient energy generation using renewable resources to cater for growing demand and to counter the dependency on the fossil fuels, the need for this study has arisen in this region. Suitable planning of energy-cognizant buildings requires a balance between the thermal performance of the building and the appropriate selection of techniques for heating and cooling.

It also necessitates thermal comfort which comes from an adequate quality of the indoor climate. Fig.1 displays some of the general practices to reduce cooling loads in a building.

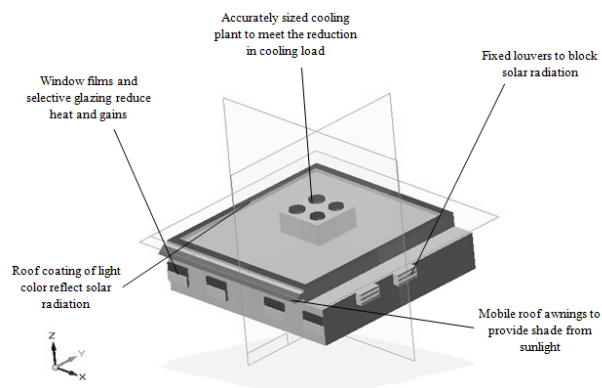

Fig. 1 General techniques to reduce cooling load in a commercial building

II. LITERATURE REVIEW

Studies related to implementation of renewable energy as power sources in buildings, in particular wind energy is rapidly increasing. Following is a concise assessment of prior work related to this investigation.

Hughes and Ghani [5] carried out work on determining the overall feasibility of sustainable development by decreasing the running expenses of buildings. A passive ventilation device known as windvent was used in the computational fluid dynamics based numerical analysis of wind velocities ranging between 1-5 m/s. The investigation confirmed that even at low wind velocities, the windvent was able to provide the desired rate of fresh air supply into the building, hence concluding that the device is suitable for sustainable ventilation systems.

Chaudhry and Hughes [6] investigated the feasibility of reducing the energy consumption of the rotating tower in

¹ Dr. Ben Hughes is head of Dubai Energy Research Group, School of Engineering and Physical Sciences, Heriot-Watt University, Block 2, Dubai International Academic City, Dubai, PO Box 294345, United Arab Emirates. e-mail: b.r.hughes@hw.ac.uk

Dubai, by drawing a comparison between integrating wind turbines inside the building. The study included computational fluid dynamics based numerical model and the results displayed that almost 20% of the building's electricity consumption could be reduced by utilizing wind turbines inside the geometry.

Muller *et al.* [7] studied the practice of utilizing vertical axis wind turbines in high-rise structures. The work developed graphical models to analyze the theoretical efficiency of the Sistan type windmill by making uncomplicated adjustments. The study supports the initiative of integrating wind energy converters into buildings by employing geometry changes to the model under study in order to indicate the maximum expected convertor efficiency of 61%.

Mithraratne [8] investigated the wind turbines mounted on roof-tops, which are involved for microgeneration in municipal houses in New Zealand. The research focused on energy consumption over a lifetime of the wind turbine with respect to the energy generation and Green House Gas (GHG) emissions from the respective at various circumstances in the life cycle. The work concluded that the feasibility level of roof-top wind turbines is generally poor as compared to large scale wind turbines for microgeneration.

Shun *et al.* [9] carried out research to employ solar and wind energy as a means of power production for hybrid ventilators for various Heating Ventilating and Air Conditioning (HVAC) systems in buildings. The investigation was based on models comparing ventilator performance at different cell voltages and wind speeds respectively. The investigation found out that much enhanced performance characteristics could be obtained from the hybrid ventilator by extraction of solar and wind power in comparison with the current ventilation techniques.

Bahaj *et al.* [10] studied the importance of micro-wind turbines on electrical energy utilization in building configurations. The research was based on various cities in the U.K. in accordance with accurate wind speed data, to evaluate the financial feasibility and appropriateness for domestic houses. The research concluded that areas of high wind speeds are most likely to benefit from micro-wind turbines as the payback period is notably less than the design lifetime and a significant reduction in carbon footprint is likely.

Lui *et al.* [11] carried out work on the viability of implementing wind energy as a major power source for buildings in Hong Kong. The study comprised of CFD modeling based on energy and turbulence for analysis of various building structures. The research concluded with the aid of simulation results, that the height of high-rise buildings could be exploited to its optimum capability to improve the efficiency of wind turbines for power generation.

From the above mentioned previous work related to utilization of wind energy in buildings. Most of the researches highlighted on energy reduction using wind power. This work focuses primarily on energy production using the respective renewable wind technology. One of the foremost drawbacks in implementing the wind turbine technology is its respective

set-up area. This is a greater disadvantage if the building is based in an urban or a sub-urban environment. However, by implementation of the turbines inside the structure is a potential solution, the broad feasibility of which will be investigated in depth in this paper.

III. WINWIND 3.0MW WIND TURBINE

Based on the recent investment of Masdar City [12] in WinWind wind turbine manufacturers, serious contemplation on implementing renewable wind energy in the region has arisen. One of the products of WinWind Ltd. includes the WinWind 3.0MW wind turbine whose performance and electric power generation capability forms the basis of this section.

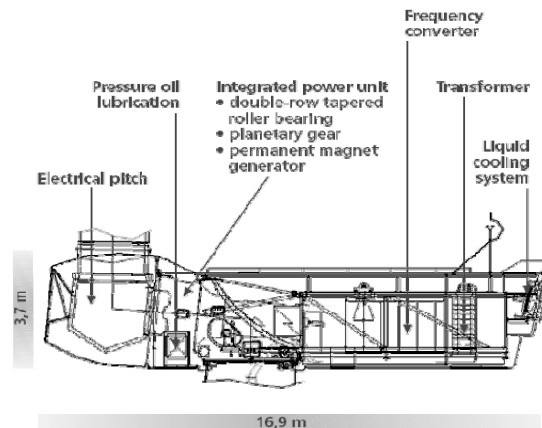

Fig. 2 Schematic of the WinWind 3.0MW wind turbine showing the major components[2].

Fig. 2 is a schematic of the nacelle of the WinWind 3.0MW wind turbine showing its major components. A tapered roller bearing is used to connect the rotor hub to the gearbox casing. The bearing transfers the rotor loads directly to the main casing, in process keeping the drive train free from excessive rotor loads. The planetary gear train increases the rotating speed and transfers the torque to the low-speed permanent magnet generator. The frequency converter transfers the full generator power. The machine produces efficient and reliable power even at low to moderate wind speeds. The WinWind 3.0 MW Wind turbine operates on Multibrid technology [13]. Multibrid is an upcoming and advanced concept in the performance of wind turbines which uses a planetary gear system along with a low-speed permanent magnet generator. The conceptual model consists of a single-stage planetary gear along with a low speed generator and a frequency convertor, with the main advantages being the elimination of high speed components thus keeping a higher strength to weight ratio. The mechanical forces are managed with the main bearing which is designed to undertake all the rotor loads. The turbine supports an all enclosed structure to shield the components from dust particles. This technology results in high efficiency starting from low wind speeds. Since the overall method is automatic, the power production and the generator control system are optimized and the maintenance levels required are

significantly lower compared to the traditional system. The wind turbine therefore is robust and reliable and has a longer working life time than the traditional turbines [13]. Having stated the functionality of the proposed WinWind 3.0MW turbine, the following section highlights the design model for the investigation.

IV. ROTATING TOWER CONCEPTUAL DESIGN

The rotating tower is one of the green projects scheduled to be built in Dubai. Once complete, it will stand at 420 meters and will comprise of 78 floors [3], each with the freedom to rotate about its own axis. The computer aided design for this investigation comprised of 8 individual floors from ground level in a 1:200 ratio. This is displayed in Fig.3.

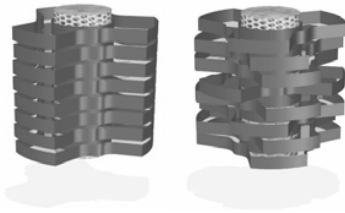

Fig. 3 CAD scale model of the rotating tower design

An imperative aspect about the rotating tower is the spacing between individual floors which is approximately 20% of the floor height itself. This spacing is to accommodate for the wind turbine blades integrated inside the building structure. The height of each floor is 5.2 meters and hence, the spacing is approximately 1 meter. This information is predominantly important as it forms the core of the Computational Fluid Dynamics results which will be discussed in the following sections.

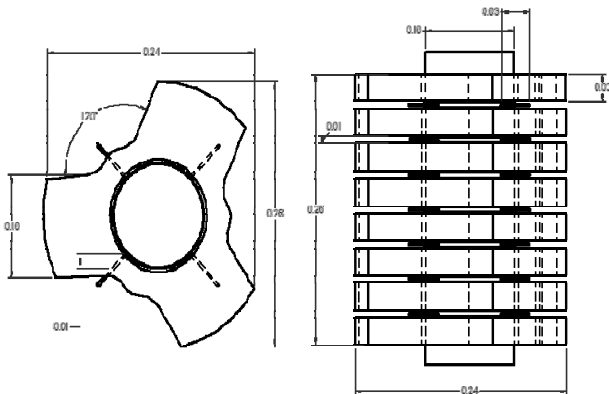

Fig. 4 Front and top view of the building structure

With reference to Fig.4, the top and front views of the designed tower are displayed. Fig.5 displays the perspective views of the scaled model of the rotating tower designed using the 3D CAD modeling software. Eight out of the seventy eight floors are displayed in the figure for Computational Fluid Dynamics analysis.

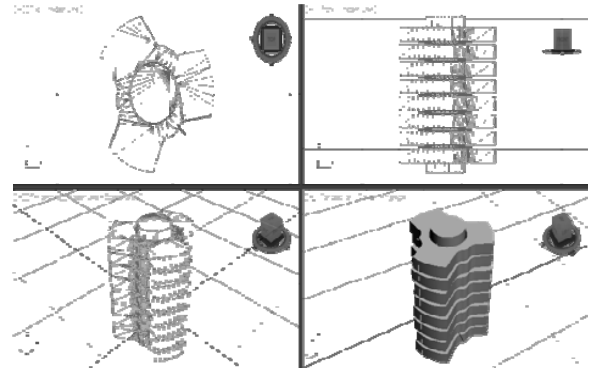

Fig. 5 Perspective views of the scaled design model.

4.1. Computational Fluid Dynamics for design analysis

The purpose of applying Computational Fluid Dynamics (CFD) is to model the design as precisely as possible. The use of CFD in monitoring various parameters associated with energy and buildings is widespread. Also, the integration of CFD program can provide a more accurate prediction of building energy use due to the complimentary information provided by the respective [15].

In addition, integrating CFD and building simulation on a single computational framework can provide means for tackling various problems associated with buildings to improve the validity of the scheme under study [16]. CFD is used in order to analyze the air flow around the designed building structure. The meshed model comprised of 45 individual parts along with 407,516 nodes and 1,816,293 elements. The maximum layers were kept to 5 and the minimum and maximum face sizes were kept as default settings. The enclosure is created 2.5 times the length of the solid geometry to create an environment for the fluid flow. The CFD analyses were carried out using the ANSYS v12.1 software package. The boundary conditions for the CFD model are displayed in Table I. The geometry was analyzed with varying wind speeds to ensure the precision of the results remain in accordance.

Besides, the geometry was modeled as a solid structure to allow the air to pass around it, rather than through it in order to determine the variation in wind velocity from inlet to outlet. The viscous model used is standard k-epsilon and the acceleration due to gravity is -9.81m/s^2 in the downward direction. The results obtained from the CFD analysis is displayed in the next section, followed by the discussions and comparison between the CFD and theoretical model in order to determine the accuracy, of the investigation and thus, the viability of the proposed study.

TABLE I
BOUNDARY CONDITIONS FOR CFD ANALYSIS

Feature	Characteristics
Geometry	Solid (aluminum)
Enclosure	Fluid (air)
Operating Velocity	3.0 m/s, 4.0 m/s, 5.0 m/s and 3.7 m/s
Operating Pressure	Atmospheric
Viscous Model	k-epsilon (2 eqn)
Near-Wall Treatment	Standard Wall Functions
Velocity Formulation	Absolute
Solver Type	Pressure-Based
Time	Steady
Gravity	-9.81 m/s ²

V.RESULTS

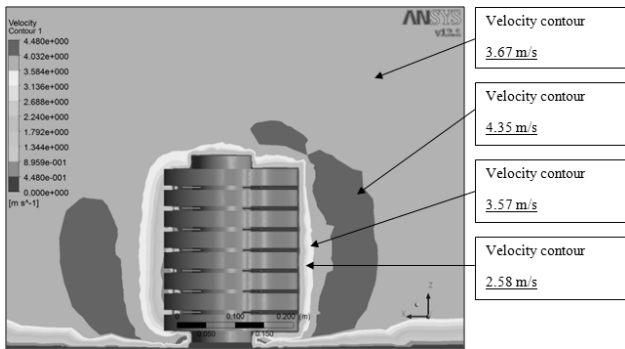

Fig. 6 Velocity contour representation – front view

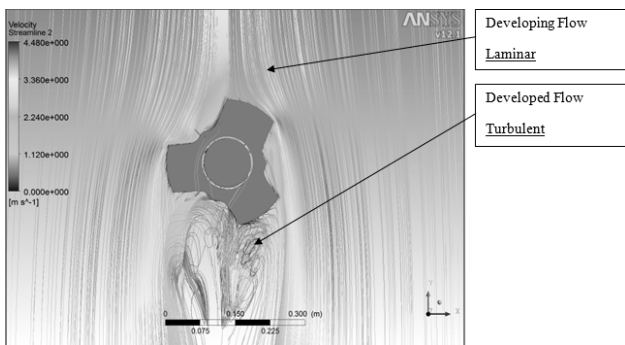

Fig. 7 Velocity streamlines distribution – top view

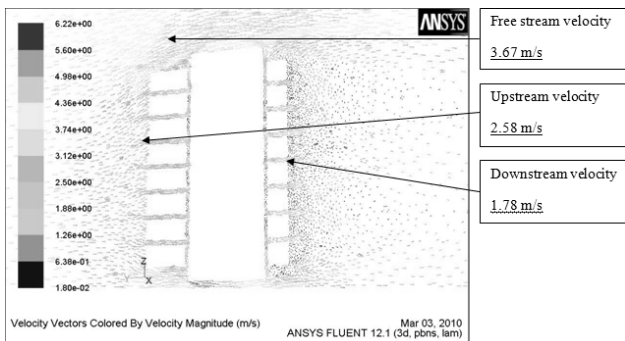

Fig. 8 Velocity vectors representation – cross-sectional view

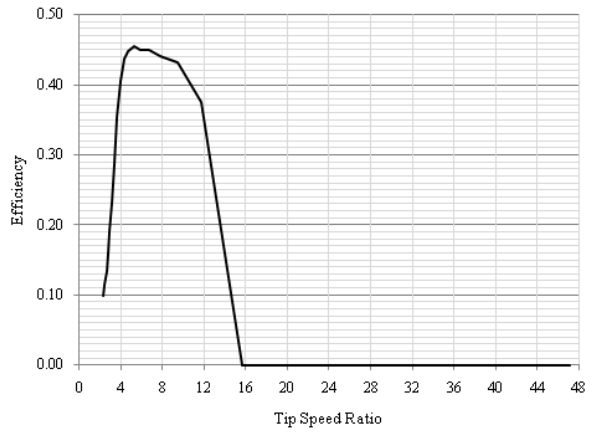

Fig. 9 Plot of tip speed ratio vs. efficiency.

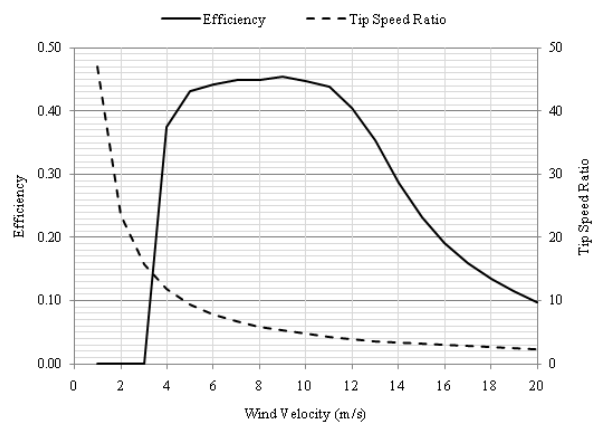

Fig. 10 Variation of efficiency and tip speed ratio with increasing wind speed.

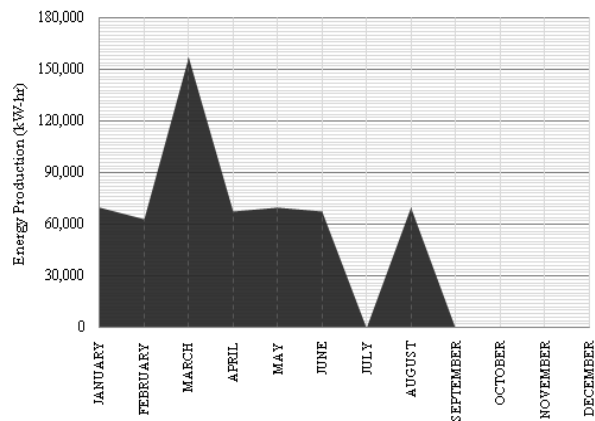

Fig. 11 Monthly energy production from the WinWind 3.0MW horizontal axis wind turbine

The relevant results obtained from the theoretical model of the WinWind 3.0MW wind turbine are compared with the

CFD results respectively which are confirmed by the experimental results on the prototype.

TABLE II
COMPARISON OF THE WIND TURBINE ORIENTATION [3]

WinWind 3.0MW Performance	Horizontal Orientation	Vertical Orientation
Power Consumption of Tower (W)	7,000,000	7,000,000
Power Production by turbine (W)	775,000	153,220
Number of Wind Turbines Installed	9	46
Individual Blade Length (m)	44.0	9.0
Total Number of Blades	27.0	138.0
Average Dubai Wind Speed (m/s)	3.7	3.7

TABLE III
EXPERIMENTATION RESULTS OBTAINED

Case	Upstream Velocity	Experimental Difference	Computational Difference	Accuracy
1	3.04	24.10%	22.00%	91.28%
2	3.19	20.15%	22.00%	91.59%
3	3.11	22.36%	22.00%	98.38%
4	2.88	28.07%	22.00%	78.37%
5	3.02	24.56%	22.00%	89.57%
6	2.95	26.32%	22.00%	83.58%
7	3.12	21.93%	22.00%	99.68%

VI. DISCUSSION

The detailed results for the actual air speed in between the floors are obtained using in-depth CFD analysis. The emphasis is based on the pattern observed for velocity vectors and contours which highlighted the actual air velocity hitting the blades of the wind turbine embedded between each floor. Fig.6 and Fig.7 displays the velocity contour and streamlines diagram for the scaled model of the rotating tower.

With reference to Fig.6, the decreasing color gradient from orange to light blue can be observed. This indicates that the free stream velocity decreases as it hits the building structure. The free stream velocity for the investigation is taken to be 3.67m/s which is the annual average wind speed is for the year 2009. Fig.7 displays the air streamlines distribution along the tower. As observed, the flow enters as laminar from the inlet (top of the diagram) and shears away as it hits the building structure. As a result, turbulence is created at the back of the tower due to adverse pressure gradient. The velocity vector diagram is displayed below for the respective.

As observed from Fig.8, the air velocity vectors between each floor are dark green in color compared to the free stream velocity vectors which are predominantly yellow. The flow direction is from left to right side of the figure. Therefore, the investigation based on CFD analysis produced a decrease in air velocity of approximately 22% when hitting the turbine blades located in between the floors of the building.

Consequently, the power production of integrating the WinWind turbine inside the building structure would be lower compared to the power production by the same wind turbine in the more conventional horizontal orientation.

6.1. Performance Analysis

Calculations based on dimensional analysis of the wind turbine are carried out and the efficiencies at various wind speeds are obtained. With reference to Fig.10, performance information was obtained. The first findings were based on the efficiency variation. As displayed, the wind turbine operates around its maximum efficiency with the wind speeds ranging between 6m/s and 10m/s. The efficiency starts to decrease as the wind speed exceeds 10m/s, with the least working efficiency observed at a wind speed of 20m/s. The maximum efficiency value calculated is 45.54% at 9m/s. The corresponding tip speed ratio is therefore 5.24 as displayed in Fig.10.

Fig.9 displays the comparison results obtained between the tip speed ratio and the efficiency of the wind turbine. It is observed that the maximum efficiency is obtained when the tip speed ratio approaches 5, thus the rotational velocity of the turbine blades is 5 times higher than the linear velocity of the wind. Tip speed ratios should always be greater than 1, thus the rotor blades of the wind turbine should always have a rotational velocity greater than the linear wind velocity for a proficient wind turbine operation. Another observation from Fig.9, is that the efficiency of the wind turbine becomes zero when the tip speed ratio is 16 and above. In conclusion, this proves that in general, wind turbines operating at extremely high tip speed ratios can be least efficient.

6.2. Comparison between the CFD and theoretical model

Following the detailed performance analysis of the standard WinWind 3.0MW wind turbine, the direct comparison can be drawn between its orientations respectively for power generation in buildings. The modeling and comparison is based on analyzing the rotating tower located in Dubai, United Arab Emirates. The breakdown with respect to each month is displayed in Fig.11. The energy production is based on the average monthly wind speeds in Dubai and as shown, the energy production falls to practically zero throughout the last quarter. However, taking the rotating towers as a structural reference for the investigation, the wind turbine can also be oriented vertically inside the building to produce the required power. Hence, by using computation fluid dynamics, accurate air flow around the tower is modeled to determine the overall power and efficiency of utilizing integrated wind turbines in buildings.

Table II displays the assessment information with respect to the orientation of the wind turbine. The conventional HAWT consists of 3 blades and therefore approximately 9 turbines would be required in a wind farm arrangement to provide the power required for the building structure. However, by utilizing the turbine in the vertical orientation, the overall length of the blade would reduce by a factor of 5 in order to accommodate itself inside the structure as the total length of each individual floor is 52 meters. Therefore, a total of 138 blades would be necessary to generate the required power for the building structure.

Based on the typical areas of industrial wind facilities, the required set-up area for a wind farm of 9 turbines is 800 acres, which is approximately 3,237,485 m² [14]. Considering an urban city like Dubai, this land space would be highly expensive to purchase and additionally, would require an electricity grid to provide the required power to the building structure. However, by integrating the wind turbines inside the structure itself, the set-up of a wind farm is excluded and consequently, the land area requirements for the respective would come down to a minimum.

6.3. Validation of the CFD model

The scaled working prototype based on the design model of the rotating tower is constructed to verify the accuracy of the CFD results. The model was built to a scale of 1:200 and demonstrated the rotation technique and the location of wind turbines on the building structure.

Fig.12 displays the scaled working model. Fluid flow experiment was conducted on the model. The apparatus used for conducting the lab experiment consisted of hot-wire velocity probe, which was placed in the flow. The probe was connected to a Testo 435-3 multi-functional meter [17] which displayed the simultaneous readings of velocity and pressure.



Fig. 12 Prototype of the rotating tower structure

Table III displays the accuracy results. The free stream velocity was kept constant at 4m/sec and the upstream velocity at the wind turbines in between the building floors was measured at various time intervals. The percentage difference between the experimental readings varied between 21% and 29%. This was compared to the percentage variation produced by the CFD analysis to determine the precision of the project. Fig.13 displays the chart for the experimental and computational velocity gradient.

VII. CONCLUSIONS

The project demonstrated the scope of generating power by implementing wind turbines inside the rotating tower geometry. The investigation proved that, by integrating the wind turbines inside the building configuration, a significant reduction in land set-up area for a horizontal axis wind farm was possible.

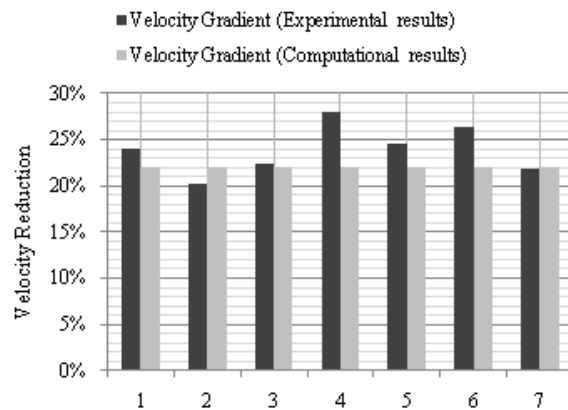

Fig. 13 Experimental and computational data comparison

With respect to electricity generation capability, the study revealed that the standard horizontal orientation of the wind turbine yielded 80% better results. On the other hand, similar power production is possible using the vertical orientation, at the expense of installing more number of equipment. Since the rotating tower will comprise of 78 floors, the investigation concluded that 46 scaled wind turbines in the vertical orientation would be sufficient to accommodate itself inside the building structure and therefore provide the essential power for the respective.

ACKNOWLEDGMENT

The authors thank the Dubai International Airport for providing the matrix for hourly wind direction and speed for 2009.

REFERENCES

- [1] M. Asif, T. Muneer, R. Kelley, "Life cycle assessment: a case study of a dwelling home in Scotland", *Building and Environment* 42 (2007)
- [2] WWD-3 Technical Specification. [Online] 2009. [Cited: September 24, 2009] Available from <http://www.winwind.fi>.
- [3] H. David Fisher, *Rotating Tower Dubai*, Rotating Tower Technology International Limited (UK) 2008
- [4] F. Allard, "Natural Ventilation in Buildings" – A design handbook (p1-3), European Commission Directorate general for Energy Altener Program
- [5] B.R. Hughes and S.A.A. Abdul Ghani, "Investigation of a windvent passive ventilation device against current fresh air supply recommendations", *Energy and Buildings*, 2008
- [6] H.N. Chaudhry and B.R. Hughes, "Computational Analysis of Dynamic Architecture", *Journal of Power and Energy*, Article in press
- [7] G. Muller, F. Jentsch Mark and E. Stoddart, "Vertical axis resistance type wind turbines for use in buildings", *Renewable Energy* 2008
- [8] N. Mithraratne, "Roof-top wind turbines for microgeneration in urban houses in New Zealand", *Energy and Buildings* 2009
- [9] S. Shun, and A. Ahmed Noor, "Utilizing wind and solar energy as power sources for a hybrid building ventilation device", *Renewable Energy* 2007
- [10] A.S Bahaj, L. Myers, and P.A.B. James, "Urban energy generation: Influence of micro-wind turbine output on electricity consumption in buildings", *Energy and Buildings* 2006
- [11] L. Lu, and K.Y. Ip, "Investigation on the feasibility and enhancement methods of wind power utilization in high-rise buildings of Hong Kong", *Renewable and Sustainable Energy* 2007

- [12] Wind Energy News [Online] 2008. [Cited: October 28, 2009] Available from <http://www.windenergynews.com/content/view/1418/45/>.
- [13] L. Matti, EEP-Applicability of WinWind turbines to Central American conditions. San Jose, Costa Rica:WinWind Oy.
- [14] Areas of industrial wind facilities [Online] 2009. [Cited: February 19, 2009] Available from <http://www.aweo.org/windarea.html>
- [15] J.Z. Zhiqiang, and Y.C. Qingyan, "Performance of coupled building energy and CFD simulation", Energy and Buildings 2005
- [16] M. Bartak, I. Beausoleil-Morrison, J.A. Clarke, J. Denev, F. Drkal, M. Lain, I.A. Macdonald, A. Melikov, Z. Popioek, and P. Stankov, "Integrating CFD and building simulation", Building and Environment 2002.
- [17] Testo Product Services [Online] 2010, [Cited: February 27, 2010] Available from [http://www.testo.com/online/abaxx-? \\$part=PORTAL .INT.ProductCategoryDesk&\\$event=show-from-menu&categoryid=1275643](http://www.testo.com/online/abaxx-? $part=PORTAL .INT.ProductCategoryDesk&$event=show-from-menu&categoryid=1275643)

Dr Ben Richard Hughes is the Research Project Outreach Co-ordinator for Heriot Watt University, Dubai Campus.

He has spent 16 years as a Mechanical Engineer from apprentice to doctorate and in 2009 was elected as a Sir Joseph Whitworth Scholar in recognition of this achievement.

Dr. Hughes has previous experience of designing, patenting, licensing new products and providing consultancy to local industries has resulted in commercial success for both academic institutions and commercial ventures.

Mr. Hassam Nasarullah Chaudhry was born in Lahore in 1987. He completed his undergraduate degree in Mechanical Engineering with first-class honours from Heriot-Watt University, Dubai Campus.

He is currently pursuing his PhD under the supervision of Dr. Hughes. His published work include: Computational Analysis of Dynamic Architecture, (Dubai, U.A.E.: IMechE, Journal of Power and Energy, 2010).

Mr. Chaudhry is an affiliate member of the IMechE. He won the 'Excellence in Engineering Award' from Wood Group Engineering and Production Facilities in 2009. His former work experience includes Quality Assurance and Quality Control services for the Meydan Project in Dubai.